



WaterBoost

ATX Whole-House Mains Pressure Booster

Installation, Operation & Maintenance Guide

Please leave this guide with the property owner — it contains important warranty, maintenance and safety information.

WRAS APPROVED

5 YR TANK · 3 YR PUMP

WIFI · DCONNECT APP



1. Product description

The WaterBoost ATX is an integrated whole-house mains pressure booster that combines a sealed accumulator vessel with a variable speed inverter pump in a single kit. Connected directly to the incoming cold water mains, the ATX automatically boosts both pressure and flow throughout the property the moment a tap, shower or outlet is opened.

Unlike traditional break-tank boosters, the ATX operates as a fully sealed closed circuit — no open water surface, no overflow arrangement and no loft tank required. The variable speed pump measures incoming mains pressure continuously and produces only the shortfall needed to hit the target outlet pressure, delivering consistent performance with minimum energy consumption.

The ATX kit ships with the accumulator vessel pre-assembled and the integral bypass block fitted — allowing the property to run on direct unboosted mains immediately. The supplied **WaterBoost Compact 3.0** variable speed pump is docked in place of the bypass block during installation to bring the booster online. See Section 6 for docking procedure.

The ATX is suitable for direct cold mains connection only. It must not be used for any other application or with any water source other than cold potable mains supply without written consent from WaterBoost.

2. Storage

If the unit is not to be installed immediately, store it upright in a dry, frost-free, vibration-free location in its original packaging. Do not expose to temperatures below 4°C or above 35°C. Keep the unit upright at all times — do not lay it on its side during transit or storage. Store the Compact 3.0 pump in the same conditions, kept in its protective packaging until ready to dock.

3. Safety warnings

- Must be installed by a qualified plumber in accordance with current Water Regulations and Building Regulations.
- Electrical connection must be carried out by a qualified electrician. The unit requires a 230 V RCD-protected fused spur.
- Ensure the floor or surface is sufficiently strong to support the full weight of the unit when filled with water. See Technical Specifications for filled weights.
- The unit must be installed upright and secured to the floor using appropriate fixings to prevent toppling.
- Always isolate the water and electrical supply before carrying out any work on the unit.
- Never attempt to dismantle the accumulator vessel — it is a sealed pressurised component.
- Do not use if the unit shows signs of corrosion, damage or leakage.
- The mains bypass block must be in place, or the Compact 3.0 pump fully docked with both clips engaged, before pressurising or powering the system.

WARNING: Depending on the model, two people may be required to position the unit safely. The ATX-200 weighs approx. 48 kg empty and 248 kg when filled with water. Lifting aids should be used where appropriate.



4. Location

Access: The unit must be readily accessible for commissioning, monitoring and pump docking / undocking via the EsyDock system.

Protection: Install in a dry, frost-protected internal location. Avoid high humidity, excessive condensation or salt-laden environments. Do not install outdoors.

Mains pressure: A minimum incoming mains static pressure of 0.7 bar is recommended for optimal performance. The ATX will operate at lower incoming pressures but with reduced peak flow capability.

Electrical supply: A 230 V AC RCD-protected fused spur is required within 1 m of the unit. Verify the supply is suitably rated for the pump load before installation.

WiFi coverage: For DConnect app functionality, the installation location must have adequate WiFi signal. If coverage is marginal, consider a WiFi extender.

Floor loading: Ensure the floor can support the weight of the unit when full. See Technical Specifications section.

Pipework: Pipework to and from the unit must be independently supported and clipped to prevent stress on connections.

Space: Allow minimum 150 mm clearance above, 300 mm at the front (pump docking access) and 50 mm to each side for installation, commissioning and ongoing pump access.

NOTE: The ATX connects from the left or right side — the two ¾" BSP male ports are multi-directional and can be rotated 180° on the vessel to suit cable and access routing, allowing flexible installation in any cupboard, wall or pipework layout.

5. What's included

Supplied with every ATX kit

ATX accumulator vessel — bypass block pre-fitted

WaterBoost Compact 3.0 variable speed pump

EsyDock pump dock, 2 × retaining clips, 4 × O-rings

On-pump HMI display — pre-commissioned

2 × ¾" BSP elbow connectors

Inlet and outlet ¾" flexible hoses

Installation, operation & maintenance guide

Compact 3.0 pump quick guide

DConnect app setup QR code

Warranty registration card

Required — not supplied

Double check valve (upstream)

230 V RCD-protected fused spur

Suitable floor fixings for anchoring

Drain connection (where building layout requires)

PTFE tape or liquid thread seal

NOTE: Check all components within 24 hours of delivery. If anything is damaged or missing, contact WaterBoost immediately at sales@waterboost.co.uk.



6. Installation

The ATX ships with the bypass block fitted so the property can remain on mains throughout plumbing-in. The **Compact 3.0 pump is docked as part of installation**, replacing the bypass block. Follow the steps below in order.

STEP 1 Unpack and inspect

- Remove the ATX vessel and the Compact 3.0 pump from their packaging and check for transit damage.
- Verify all supplied components against the "What's included" list.
- Do not install a damaged unit or pump — contact WaterBoost.

STEP 2 Position and secure the unit

- Position upright on a firm, level surface capable of supporting the filled weight.
- Allow minimum 150 mm clearance above, 300 mm at the front (pump access) and 50 mm to each side.
- Secure the base to the floor with suitable fixings to prevent movement.
- The unit must remain vertical — do not tilt, lay down or invert.

WARNING: The ATX must always be fixed to the floor. An unsecured unit filled with water presents a serious risk of toppling, causing injury or property damage.

STEP 3 Connect the upstream pipework

- Install an isolation valve and double check valve on the mains before the ATX inlet.
- Connect the cold mains supply to the inlet port using PTFE tape or liquid thread seal.
- The two ports accept inlet/outlet from either side — route pipework whichever way suits the install.
- Flux damage will void the warranty — complete all solder joints and remove residues before final connection.

STEP 4 Connect the downstream pipework

- Connect the outlet port to the downstream distribution pipework supplying cold (and hot, where applicable) services.
- All pipework must be independently supported and clipped at regular intervals.
- Locate any water softener downstream of the ATX outlet.



6. Installation (continued)

STEP 5 Remove the bypass block and dock the Compact 3.0 pump

At this point the ATX vessel is plumbed in and the bypass block is keeping the property on unboosted mains. The Compact 3.0 pump now replaces the bypass block on the dock.

A. Remove the bypass block

- Close the upstream isolation valve and open a downstream tap to release pressure.
- Slide each retaining clip outwards to release, then withdraw the bypass block clear of the dock.
- Retain the bypass block and clips — they will be needed for any future pump servicing.
- Check the four O-rings on the dock face are seated, clean and undamaged. Replace any that are pinched or missing.

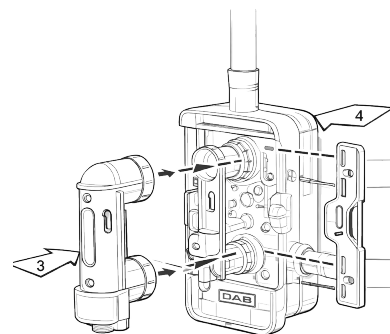

Removing the bypass. Slide each clip outwards (4), then withdraw the bypass block from the dock (3).

B. Dock the Compact 3.0 pump

- Orient the Compact 3.0 pump so the arrows on the dock face align with the IN (inlet) and OUT (outlet) ports on the vessel. The ports can be rotated 180° if cable or access routing requires.
- Lower the pump squarely onto the dock until it seats fully — do not rock or force it.
- Slide both EsyDock clips horizontally onto the dock with "UP" arrows pointing upwards. The clip fingers must be fully engaged and the clip flush against the dock before the system is pressurised.

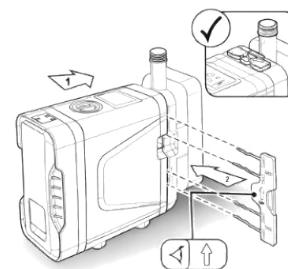

EsyDock clip engagement. Lower the pump onto the dock (1), then slide each retaining clip horizontally into place (2) with the "UP" arrow pointing upwards.

IMPORTANT: Both retaining clips must be fully engaged before restoring water or electrical supply. Operating with a partially-docked pump risks leakage, pump ejection under pressure, and will void the warranty.

STEP 6 Connect the electrical supply

- Connect to the 230 V RCD-protected fused spur — qualified electrician only.
- Do not switch power on until water connections are complete, the pump is fully docked and the unit is filled.
- Verify compliance with BS 7671 and all relevant UK wiring regulations.



7. Commissioning

IMPORTANT: The ATX vessel is pre-pressurised at the factory. Unlike a traditional accumulator, no manual air pre-charge setup is required — commission by filling, powering and verifying operation.

STEP 7 Fill and check for leaks

- Close all downstream outlet valves. Slowly open the upstream isolation valve to fill the unit — listen for air purging.
- Check all joints and the pump dock interface for leaks. Tighten or reseal as necessary.
- Open downstream outlets one at a time to verify flow and bleed any remaining air from the system.

STEP 8 Power on and verify operation

- Switch on the fused spur — the HMI display illuminates and the pump runs a self-test.
- Confirm no fault codes or red LEDs are displayed. Open an outlet and confirm the pump engages and flow is boosted.
- Close the outlet — confirm the pump ramps down to standby and the vessel recharges.
- Verify the setpoint on the HMI (default 3.0 bar). Adjust if required — see Section 9.

STEP 9 Pair the DConnect app (optional)

- Download the DConnect app, scan the QR code on the setup card or enter the unit serial number.
- Follow the on-screen steps to connect to the property WiFi network.
- Once paired, the app provides remote status, flow history, setpoint control and diagnostic alerts.



8. Operating principles

The ATX operates in two phases. **Phase 1 — Stored volume:** the accumulator delivers an instant peak burst flow of up to 45 L/min, then sustains a model-dependent boosted flow at 3.2 bar for approximately 11 minutes. **Phase 2 — Continuous mains:** once the stored volume is used, the Compact 3.0 pump boosts directly from mains at 12 L/min at 3.0 bar. When demand stops, the vessel recharges automatically.

Model	Peak burst flow	Sustained flow (Phase 1)	Duration
ATX-150	45 L/min	18 L/min @ 3.2 bar	≈ 11 min
ATX-200	45 L/min	22 L/min @ 3.2 bar	≈ 11 min
ATX-250	45 L/min	24.5 L/min @ 3.2 bar	≈ 11 min
ATX-300	45 L/min	27 L/min @ 3.2 bar	≈ 11 min
ATX-450	45 L/min	36 L/min @ 3.2 bar	≈ 11 min

Figures are nominal and depend on incoming mains pressure of at least 0.7 bar. Phase 2 continuous flow of 12 L/min at 3.0 bar is common across all ATX models.

The variable speed pump measures incoming mains pressure continuously and generates only the shortfall needed to hit the target setpoint — minimising energy consumption while delivering consistent outlet pressure.

9. Compact 3.0 HMI controls

The Compact 3.0 pump has a simple on-unit HMI with two control buttons and status LEDs. All routine settings can also be changed via the DConnect app.

Control	Function	How to use
▷ Play / Pause	Switch pump between ON (running/ready) and STANDBY (idle).	Press once. LED next to symbol indicates current state.
◀ Setpoint	Adjust target outlet pressure (setpoint) in 0.5 bar increments up to a maximum of 3.2 bar.	Hold for 3 seconds to enter setpoint mode; press repeatedly to step through values; wait 5 seconds to confirm.
Anticycling	Prevents short pump cycles caused by small downstream leaks or drips.	From standby, press ▷ and ◀ together to toggle. LED flashes to confirm state change.
Dry-run reset	Clears dry-run fault once mains supply is restored.	When red LED is lit (dry-run detected), press ▷ once to re-attempt start.
Factory reset	Restores all settings to factory default.	Hold ◀ + ▷ for 10 seconds from standby. All LEDs flash to confirm.

LED status at a glance: green = running or ready · blue = standby / WiFi · red = fault (see Section 11).



10. Technical specifications

Parameter	Value
System type	Integrated accumulator booster — direct mains
Pump	WaterBoost Compact 3.0 variable speed inverter
Max pressure	3.2 bar
Peak burst flow	Up to 45 L/min
Continuous flow (Phase 2)	12 L/min at 3.0 bar
Setpoint range	Up to 3.2 bar (0.5 bar steps)
Noise level	40 dB(A)
Water connections	2 × ¾" BSP male · multi-directional (left or right)
Electrical supply	230 V AC · RCD-protected fused spur
Pump IP rating	IPX4 (pump) / IPX5 (supply lead)
Operating temperature	4–40°C ambient · 35°C max water
Connectivity	WiFi — DConnect app + on-pump HMI
Protection & features	Sealed system · dry-run protection · anti-seize · anticycling · EsyDock quick-service
Approvals	WRAS approved
Warranty	5 years tank · 3 years pump

Model	Capacity	Useable	Sustained flow	Height	Diameter	Full kg
ATX-150	150 L	90 L	18 L/min · 11 min	1209 mm	532 mm	192
ATX-200	200 L	120 L	22 L/min · 11 min	1326 mm	532 mm	248
ATX-250	250 L	150 L	24.5 L/min · 11 min	1498 mm	534 mm	304
ATX-300	300 L	180 L	27 L/min · 11 min	1783 mm	534 mm	362
ATX-450	450 L	270 L	36 L/min · 11 min	1822 mm	662 mm	534



11. Troubleshooting

Symptom	Probable cause	Action
No flow from outlets	Mains isolation valve not fully open, or bypass clips in wrong position	Check upstream isolation valve; confirm both bypass clips in "ATX" position.
Pump running continuously	Downstream outlet not fully closed, or loss of vessel pre-charge	Check all taps and appliances for leaks. If no leak, contact WaterBoost.
Low boosted pressure	Mains supply below recommended minimum	Verify incoming mains pressure at the upstream gauge.
HMI fault code displayed	Dry run, overpressure or sensor fault	Note the fault code and contact WaterBoost support.
Pump cycles on and off with no demand	Leak in downstream pipework, or anticycling disabled	Check for leaks; re-enable anticycling via HMI or DConnect app.
Unit won't power on	Fused spur tripped, or RCD trip	Reset the RCD and fused spur. If it trips again, isolate and contact WaterBoost.

For a full fault-code reference, open the DConnect app or contact WaterBoost support with the code shown on the pump HMI.

12. Maintenance

The WaterBoost ATX is a maintenance-free system under normal operating conditions. There are no consumable parts, no filters, no scheduled service visits and no annual inspections required. The sealed pressurised design removes the hygiene maintenance obligations of open storage systems, and built-in features manage the unit's long-term health automatically.

- **Automatic:** anti-seize exercise function runs the pump briefly during low-demand periods to prevent impeller seizure.
- **Automatic:** dry-run protection monitors flow and shuts the pump down if the mains supply is interrupted.
- **Automatic:** anticycling prevents repeated short cycles caused by small downstream leaks (can be toggled on the HMI).
- **Annually (recommended):** visually inspect the unit, EsyDock clips, pump dock interface and pipework for signs of corrosion, damage or weeping joints.
- **Annually (recommended):** review DConnect app history for any intermittent fault codes or pressure anomalies.
- **Pump servicing / replacement (if ever required):** isolate water and power, slide both EsyDock clips outwards to release, lift the Compact 3.0 pump clear and refit the bypass block (or replacement pump). Slide both clips back on with "UP" arrows pointing upwards and restore supply. Property remains on mains throughout — no draining required.

WARNING: DO NOT attempt to dismantle the accumulator vessel. It is a sealed pressurised unit — any unauthorised modification will void the warranty and may be dangerous.



13. Warranty

The WaterBoost ATX is covered by a **5-year warranty on the accumulator tank** and a **3-year warranty on the Compact 3.0 pump unit**, both from the date of purchase.

The warranty covers defects in materials and workmanship. It does not cover: damage from incorrect installation, improper use, unauthorised modification, normal wear and tear, damage caused by frozen pipework, external electrical supply faults, or flux damage to connections.

To make a warranty claim, contact WaterBoost with proof of purchase and the unit model and serial number — located on the data plate at the rear of the unit and visible in the DConnect app.

To register your warranty or make a claim:

Email: sales@waterboost.co.uk

anglianpumping.com · waterboost.co.uk

Installation record — please complete and retain

Model number: _____ **Installed by:** _____

Serial number: _____ **Site address:** _____

Install date: _____ **Electrician:** _____