

WaterBoost



WaterBoost

WB-Compact 4.5 · ACF1

Accumulator Booster Pump

Accumulator booster · Floor mounted

Get in touch



WhatsApp

07464 644 830

waterboost.co.uk

anglianpumping.com

IN STOCK · FAST DISPATCH

4.5 bar

Max delivery pressure

12 L/min

Max flow rate

1"

Connection size (BSP)

Wi-Fi

DConnect app control

3 yr

Warranty

OVERVIEW

The WaterBoost WB-Compact 4.5 ACF1 is a high-performance variable-speed accumulator booster pump that automatically increases low water pressure up to 4.5 bar. Designed for floor or wall mounted installation, it can be positioned independently of an accumulator vessel, making it ideal for combination boilers, unvented cylinders, electric showers, and mixer showers.



KEY FEATURES

- Boosts mains pressure up to 4.5 bar automatically
- Flow up to 80 L/min when used with an accumulator vessel
- Variable-speed pump — silent, stable pressure at all flow rates
- Wi-Fi connected — control via DAB DConnect app
- Voice control compatible
- Floor mounted — stable, low-profile installation
- Water-cooled motor — reliable and energy efficient
- Full-bore bypass option for maintenance continuity
- WRAS approved — compliant with water authority regulations
- Made in Italy

TECHNICAL SPECIFICATION

| | |
|-----------------------|--|
| Model | WaterBoost WB-Compact 4.5 ACF1 |
| Type | Accumulator booster pump |
| Max delivery pressure | 4.5 bar |
| Max flow rate | 12 L/min (80 L/min with accumulator) |
| Connection size | 1" BSP female |
| Motor cooling | Water cooled |
| Control | Digital variable-speed inverter |
| Display | LCD display |
| Connectivity | Wi-Fi — DAB DConnect app |
| Voice control | Compatible |
| Bypass | Full-bore bypass compatible |
| Mounting | Floor mounted |
| Construction | Made in Italy |
| IP rating | IPX4 |
| Weight | 14.6 kg |
| Approval | WRAS approved |
| Operation | Silent |
| Warranty | 3 years |
| Suitable for | Combi boilers, unvented cylinders, electric & mixer showers |

IDEAL FOR

- Combination boilers with low pressure
- Unvented hot water cylinders
- Electric and mixer showers
- Properties with low incoming mains pressure
- Whole-house pressure improvement

HOW IT WORKS

- 1 Mains water supply enters the pump inline
- 2 Pump senses pressure drop and automatically activates
- 3 Variable-speed motor boosts pressure up to 4.5 bar to the accumulator
- 4 When demand stops, pump rests — saving energy

DIMENSIONS & CONNECTIONS

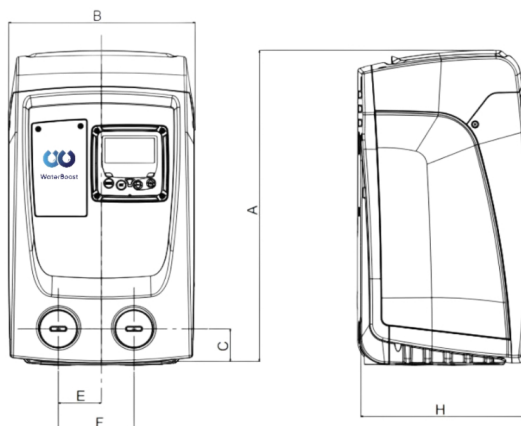

| A | B | C | D | E | F | G | H |
|-----|-----|----|-----|------|-------|-------|-----|
| 439 | 263 | 46 | 143 | 60,7 | 106,7 | 279,5 | 236 |

PERFORMANCE CURVE — WB-Compact 4.5 ACF1

