



Flow-Thru™ Anti-Legionella Series

Recirculation device for the freshest water



Features

- Patented Flow-Thru™ Technology for freshest water
- Anti-Legionella Flow-Thru system ensures colonization cannot take place as fresh water is always being forced into the water chamber
- Available in composite and steel
- Patented CAD-2 diaphragm technology
- No stagnation
- Patented water vane, total recirculation of the water
- Leak-free air valve cap sealed with closed cell foam
- Replaceable tank base (composite models only)
- Comprehensive testing
- Maintenance-free



Certifications may vary by model. Check with your GWS sales representative for more detailed information

Global Water Solutions now guarantees the freshest water quality possible with the revolutionary Flow-Thru™ series design, available in both composite and steel models. All Flow-Thru tanks feature GWS's exclusive patented Flow-Thru technology which assures that your system will provide the freshest water quality possible by simply eliminating stagnation!

The Flow-Thru connection diverts system water into, and more importantly out of the tank. Flow-Thru will work with pumped supply or direct connection to the water supply without any pump. This constant flushing action assures that the water in the tank remains as fresh as possible and eliminates the possibility of stagnant water during normal system operation.

Both our steel and composite Flow-Thru tanks incorporate our proven patented controlled action diaphragm (CAD-2). CAD-2's steel clench ring regulates movement and prevents the diaphragm from rubbing against the tank wall. Flow-Thru is also the ideal solution for constant pressure water system installers seeking to store water without the risk of stagnation.

Flow-Thru tanks are quality tested at several stages on the production line to ensure the structural integrity of every tank. Flow-Thru tanks represent the best value for the investment and are the best quality anti-stagnation tanks available today.

Flow-Thru™ Technology

Flow-Thru technology assures total recirculation of the tank's water content

1. The scoop redirects water into the tank
2. The water mixes, eliminating the possibility of stagnant water
3. The water leaves the tank

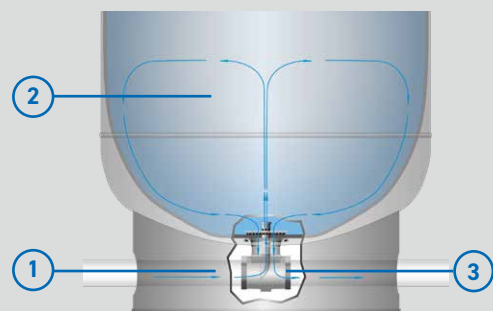

Where Water Gets Better

Models

Model Number		Connection	Nominal Volume		Dimensions (mm)			Gross Weight [kg]
BSP	NPT		Liters	Gallons	A	B	C	
Steel								
GFU-80LV	GFU-80LV	1¼" + BSP Adapter	80	21.1	736	407	51	15.4
GFU-170LV	GFU-170LV	1¼" + BSP Adapter	170	44.9	943	533	65	31.3
GFU-325LV	GFU-325LV	1¼" + BSP Adapter	325	85.8	1149	660	61	53.5
GFU-450LV	GFU-450LV	1¼" + BSP Adapter	450	118.8	1537	660	75	69.9
Composite								
CFB-60LV	CFN-15GV	1¼" BSPP / NPT	60	15.8	650	421	45	8.6
CFB-80LV	CFN-20GV	1¼" BSPP / NPT	80	21.1	865	421	45	10.9
CFB-150LV	CFN-40GV	1¼" BSPP / NPT	150	39.6	775	617	57	15.9
CFB-200LV	CFN-50GV	1¼" BSPP / NPT	200	52.8	1099	546	58	20.4

Note: Minor dimensional variations may occur.

Specifications

Product Series Name	Flow-Thru™
Nominal Volumes	60 - 450 L / 15 - 119 gal
Min. Operating Temperature	-10 °C / 14 °F (Avoid Freezing)
Max. Operating Temperature	90 °C / 194 °F (Steel) 49 °C / 120 °F (Composite)
Max. Operating Pressure	8.6 bar 125 psi
Pre-Charge Pressure	1.4 bar 20 psi

Conforms to European and UK recommendations.

Eliminates any colonization of microbial activity by constantly forcing fresh water into the water chamber.

