

HC-1A

HOT CONDENSATE PUMP



- ☑ Hot Condensate Pump
- ☑ Up to 8l/min flow
- ☑ Up to 7.5m head
- ☑ Shaded Pole Motor
- ☑ 8 Litre Tank Capacity
- ☑ Automatic pump activation on fluid level.
- ☑ High level alarm

PERFORMANCE

SPECIFICATION

FEATURES

Temp:	Max 100°C
Pressure:	6 Bar (System)
Inlet:	25mm OD Hole
Outlet:	10mm OD Plain

WETTED MATERIALS

Tank:	304 SS
Floater:	Ryton
Float Rod:	316 SS
Pump Housing:	Ryton
O-Ring:	Nitrile
Motor Shaft:	316 SS

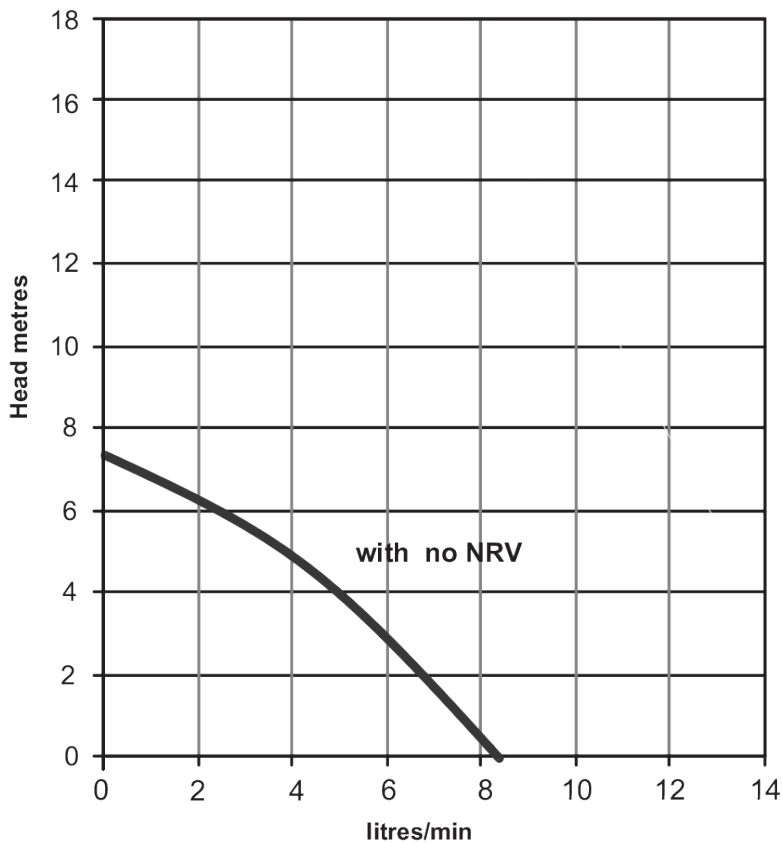

Tests obtained with water 1.0 SG

— 50 hz 2900 rpm



March May Ltd, Howard Road, Eaton Socon, St. Neots, Cambridgeshire, PE19 8NZ, UK

Tel: +44 (0) 1480 214444 Fax: +44 (0) 1480 405336 E-mail: sales@marchmay.co.uk Website: www.marchmay.co.uk

HC-1A

HOT CONDENSATE PUMP



DIMENSIONS

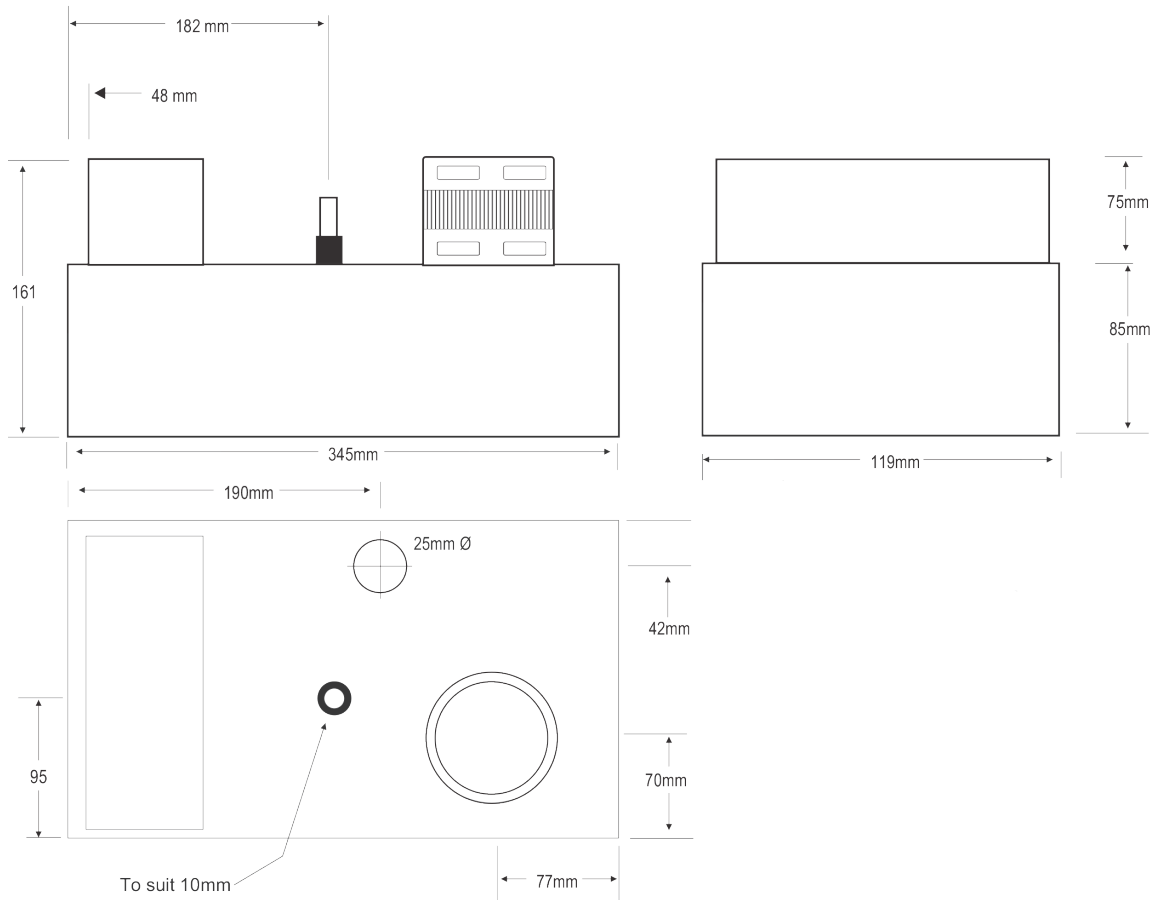

WIRING

Wiring Diagram - Open

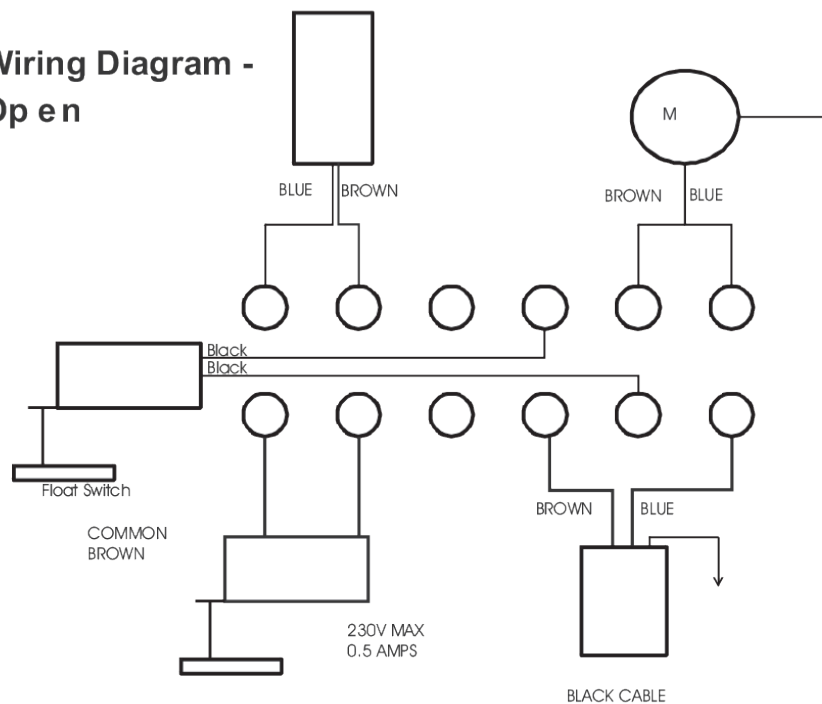

March May Ltd, Howard Road, Eaton Socon, St. Neots, Cambridgeshire, PE19 8NZ, UK

Tel: +44 (0) 1480 214444 Fax: +44 (0) 1480 405336 E-mail: sales@marchmay.co.uk Website: www.marchmay.co.uk