



water solutions

# Data sheet

## GRN 400/2/G50H A1FT5

# N

series

### Technical specification

3~ 50 Hz

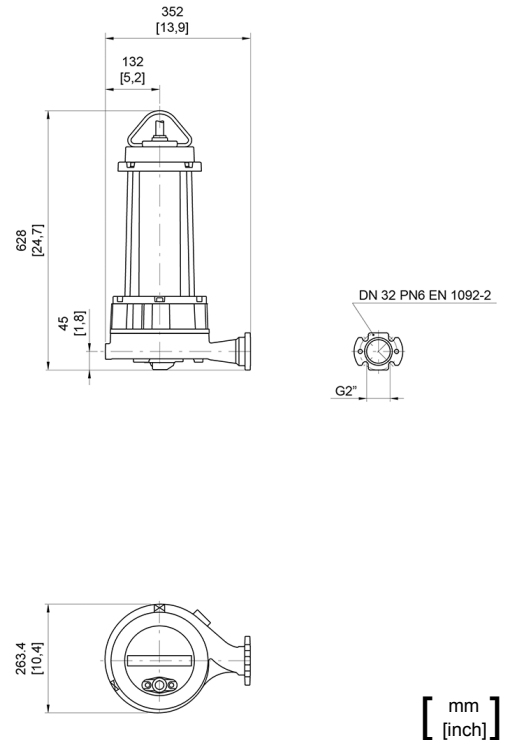
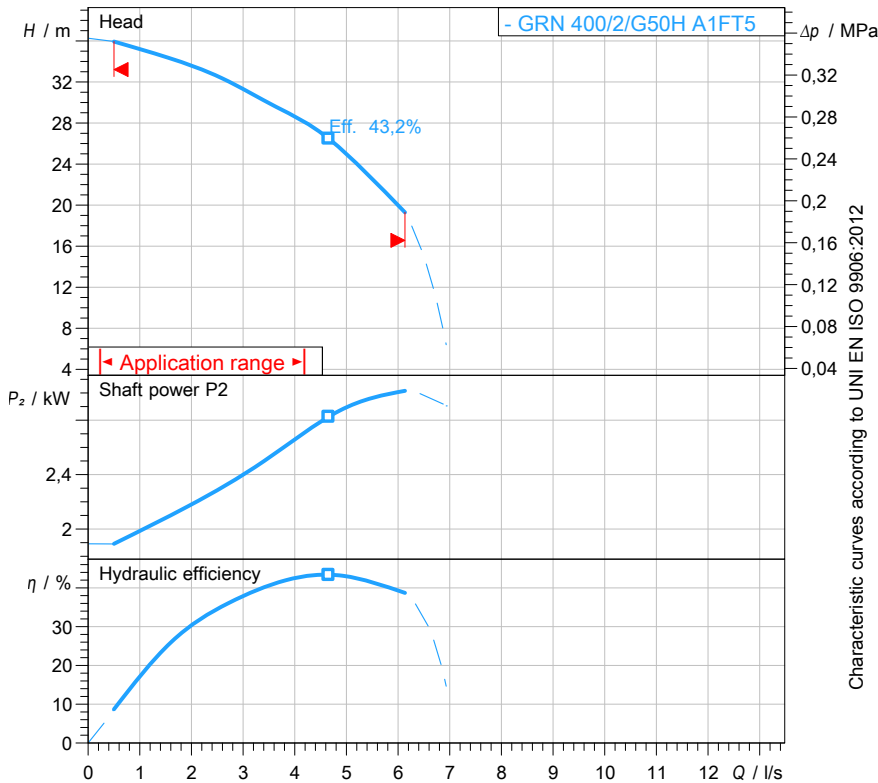

#### Pump

Series	N series
Pump name	GRN 400/2/G50H A1FT5
Configuration	NGTAB51040N00NN
Standard	EN 809:2009
ATEX mark	-

#### Operating limits (standard pumps)

Max. ambient temperature	40 °C
Max. density treated liquid	1100 kg/m <sup>3</sup>
Max. immersion depth	30 m
pH treated liquid	6 ÷ 14
Max. start per hour (equally distributed)	30
Wet/dry use	WET
Max. acoustic pressure level	70 dB
Operating mode	S1 - Continuous use

#### Motor data

Rated voltage	400 V
Frequency	50 Hz
Motor phases	3~
Number of poles	2
Rated power P2	3,00 kW
Incoming power P1	4,00 kW
Rated current	6,7 A
rpm	2842 1/min
Efficiency	76,5 %
cos φ	0,87
Rated torque	10,1 Nm
Start	Direct starting
Degree of protection	IP 68
Insulation class	H

#### Construction materials

Case	Cast iron EN-GJL 250
Shaft	Stainless steel - AISI 431
Hydraulic	Cast iron EN-GJL 250
Impeller	Cast iron EN-GJL 250
Painting/Coating	Bi-epoxy 150 μm
Screws	Stainless steel - Class A2-70
Gaskets	NBR
Cooling jacket (if present)	Carbon steel
Cutter	Chromium steel - X102 CrMo17 KU
Cutting disk	Chromium steel - X102 CrMo17 KU

#### Construction features

Cooling system	No cooling jacket
Main cable	4G1.5+3x1
Control cable	-
Cable length	10 mt
Mechanical seals	2 in silicon carbide (2SiC)
Additional drilling	-
Weight*	69 kg
Electrical variant	Thermal protection

\* cable's weight not included

#### Hydraulic

Type	GR (Impeller with grinder system)
Free passage	0 mm
Impeller type	Multi channel impeller
Max. hydraulic efficiency	43,2 %
Suction	
Discharge	DN 32 - G 2" EN 1092-2
Curve tolerance	UNI EN ISO 9906:2012



water solutions

# Data sheet GRN 400/2/G50H A1FT5

# N series

## Pump performance curves

### 3~ 50 Hz

Hydraulic type GR (Impeller with grinder system)		Impeller type Multi channel impeller		Free passage 0 mm	Discharge DN 32 - G 2"	Suction
DUTY POINT						
Flow	Head	Shaft power P2	Hydraulic efficiency	Density 998,3 kg/m <sup>3</sup>	Viscosity 1,005 mm <sup>2</sup> /s	

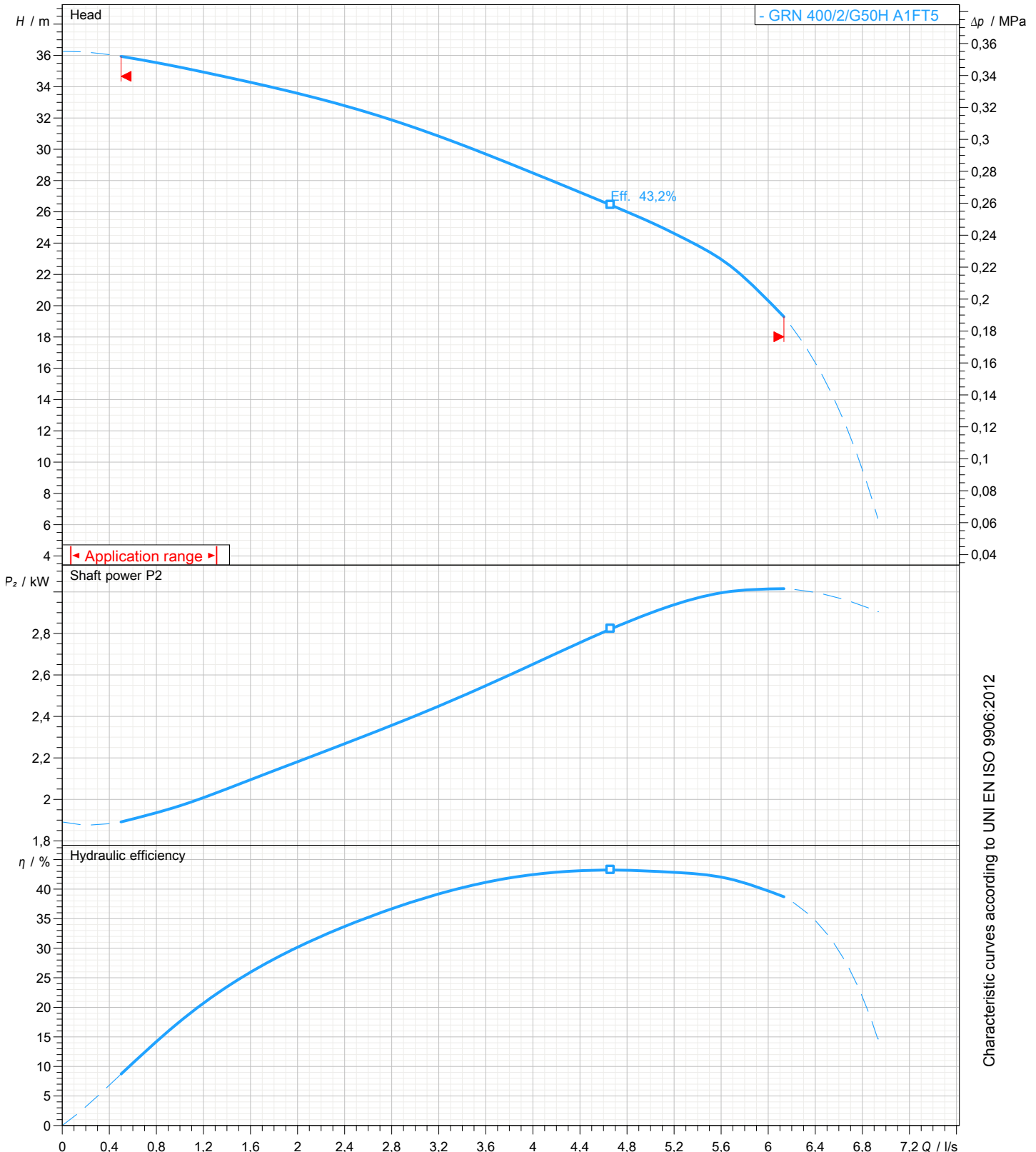



water solutions

# Data sheet GRN 400/2/G50H A1FT5

# N

series

## Dimensional drawing

3~ 50 Hz

**Installation type** Installation with bottom coupling device - Vertical outlet + GTP

WET/DRY use: WET

Discharge: DN 32 - G 2" EN 1092-2

Suction:

Pressure rating (suction/discharge): PN 6

Accessory \* : DAC 32-50/G50V-G65V 3/4" EN+GTP (P)

Accessory code \* : 9028.002

\* Accessory must be ordered separately

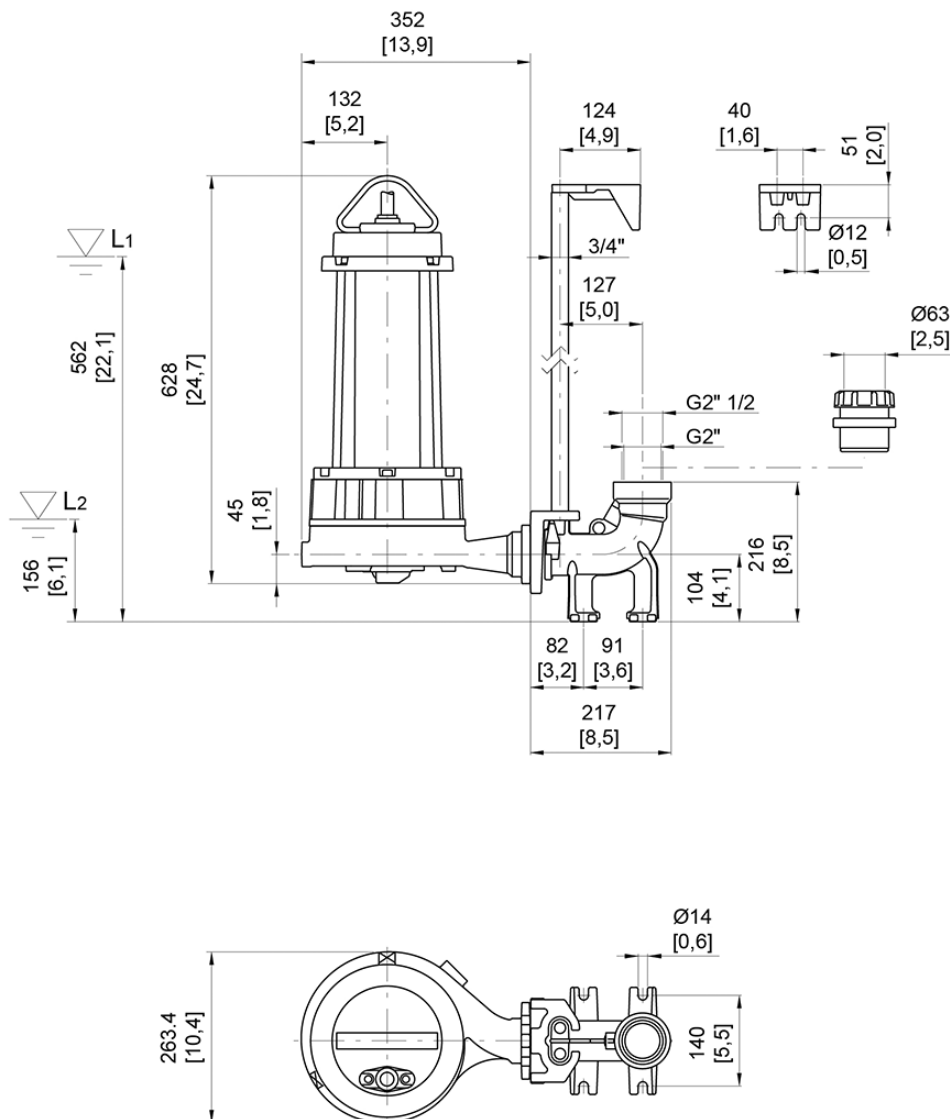

L1: Minimum operating level for continuous use

L2: Minimum operating level for discontinuous use (only "WET" version)

[ mm ]  
[ inch ]