



water solutions

Data sheet

GRN 250/2/G40H A1DM5

N

series

Technical specification

1~ 50 Hz

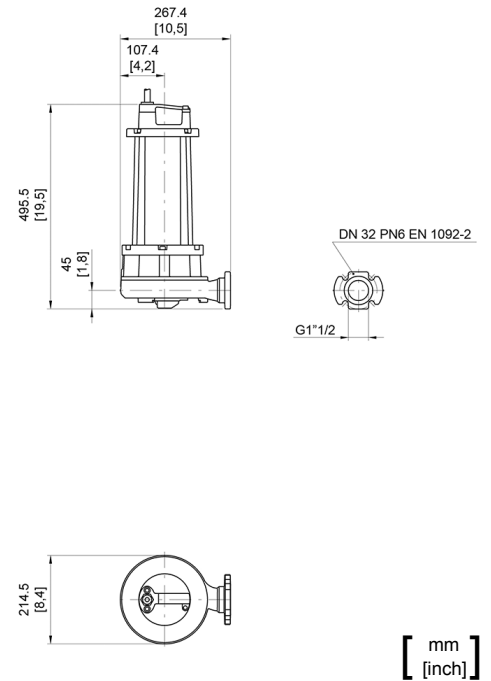
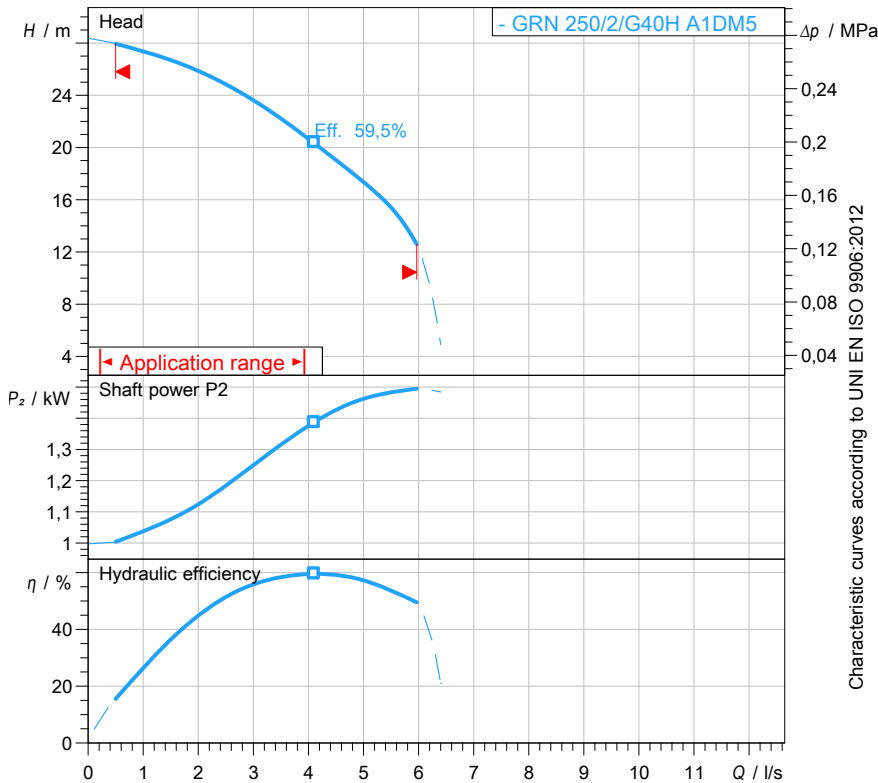

Pump

Series	N series
Pump name	GRN 250/2/G40H A1DM5
Configuration	NGTAB51023N00NN
Standard	EN 809:2009
ATEX mark	-

Motor data

Rated voltage	230 V
Frequency	50 Hz
Motor phases	1~
Number of poles	2
Rated power P2	1,80 kW
Incoming power P1	2,80 kW
Rated current	12,5 A
rpm	2792 1/min
Efficiency	69,0 %
cos φ	0,96
Rated torque	6,2 Nm
Start	
Degree of protection	IP 68
Insulation class	H

Hydraulic

Type	GR (Impeller with grinder system)
Free passage	0 mm
Impeller type	Multi channel impeller
Max. hydraulic efficiency	59,5 %
Suction	
Discharge	DN 32 - G 1 1/2 EN 1092-2
Curve tolerance	UNI EN ISO 9906:2012

Operating limits (standard pumps)

Max. ambient temperature	40 °C
Max. density treated liquid	1100 kg/m ³
Max. immersion depth	30 m
pH treated liquid	6 ÷ 14
Max. start per hour (equally distributed)	30
Wet/dry use	WET
Max. acoustic pressure level	70 dB
Operating mode	S1 - Continuous use

Construction materials

Case	Cast iron EN-GJL 250
Shaft	Stainless steel - AISI 431
Hydraulic	Cast iron EN-GJL 250
Impeller	Cast iron EN-GJL 250
Painting/Coating	Bi-epoxy 150 μ m
Screws	Stainless steel - Class A2-70
Gaskets	NBR
Cooling jacket (if present)	Carbon steel
Cutter	Chromium steel - X102 CrMo17 KU
Cutting disk	Chromium steel - X102 CrMo17 KU

Construction features

Cooling system	No cooling jacket
Main cable	4G1.5+3x1
Control cable	-
Cable length	10 mt
Mechanical seals	2 in silicon carbide (2SiC)
Additional drilling	-
Weight*	44 kg
Electrical variant	Thermal protection

* cable's weight not included



water solutions

Data sheet GRN 250/2/G40H A1DM5

N series

Pump performance curves

1~ 50 Hz

Hydraulic type GR (Impeller with grinder system)		Impeller type Multi channel impeller		Free passage 0 mm		Discharge DN 32 - G 1"1/2		Suction		
DUTY POINT										
Flow		Head		Shaft power P2		Hydraulic efficiency		Density 998,3 kg/m ³		Viscosity 1,005 mm ² /s

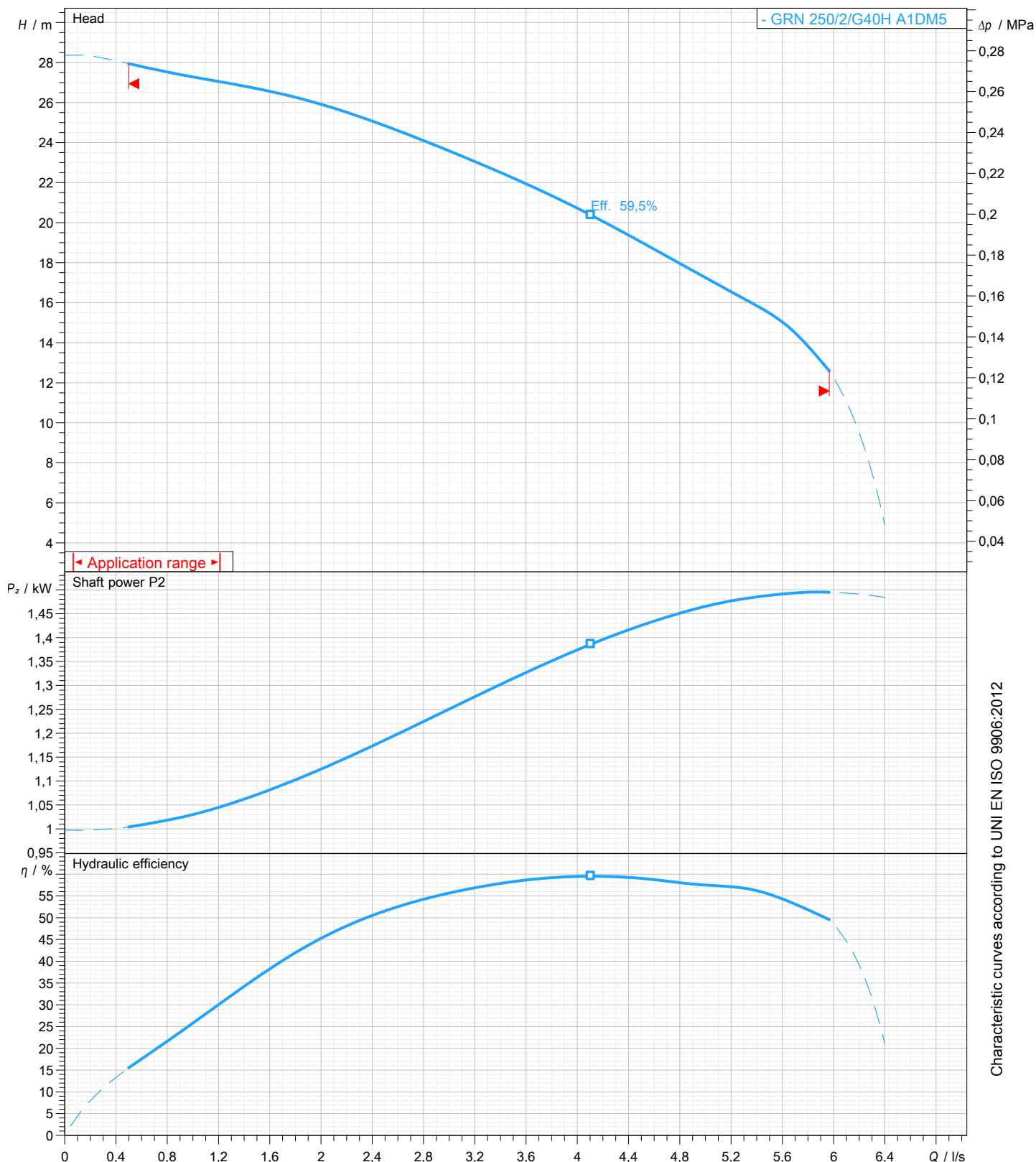

Dimensional drawing

1~ 50 Hz

Installation type Installation with bottom coupling device - Vertical outlet + GTP

WET/DRY use: WET

Discharge: DN 32 - G 1"1/2 EN 1092-2

Suction:

Pressure rating (suction/discharge): PN 6

Accessory * : DAC 32-50/G50V-G65V 3/4" EN+GTP (P)

Accessory code * : 9028.002

* Accessory must be ordered separately

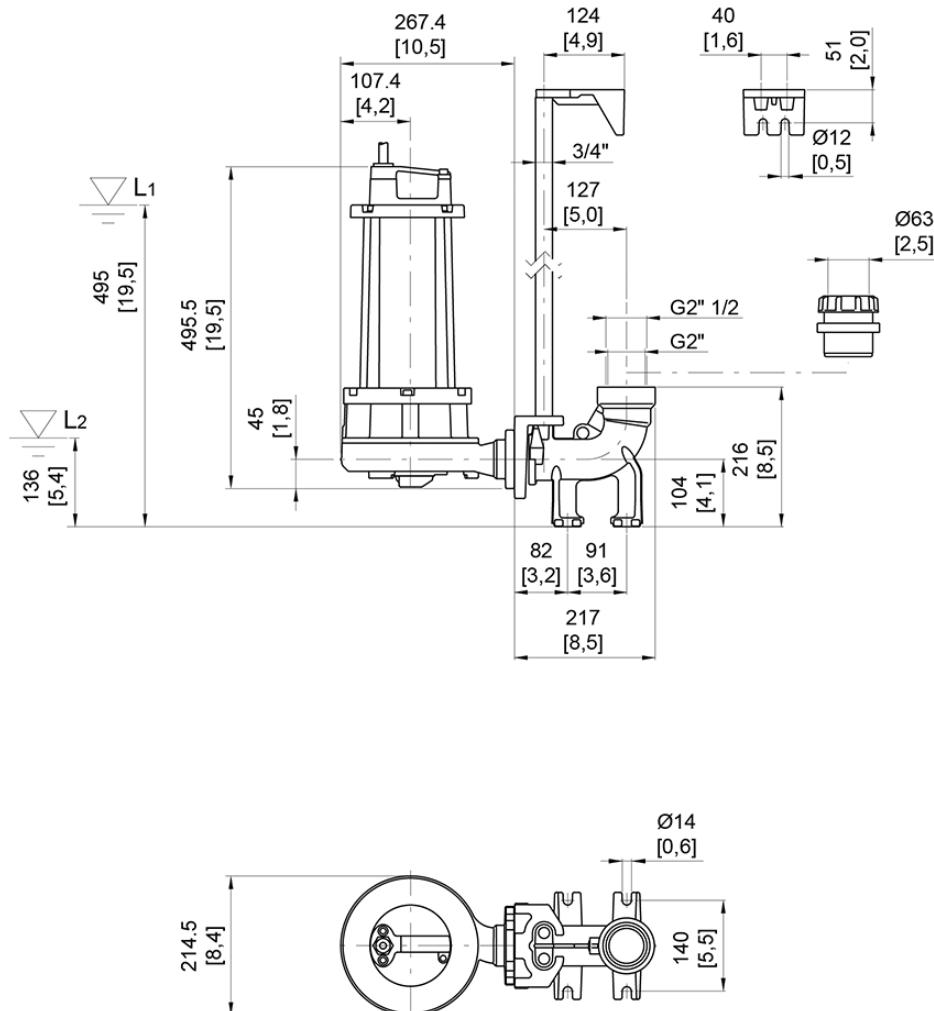

L1: Minimum operating level for continuous use

L2: Minimum operating level for discontinuous use (only "WET" version)

[mm]
[inch]