



water solutions

# Data sheet

## DR-Steel 25 M5

**Steel**  
series

### Technical specification

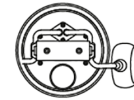
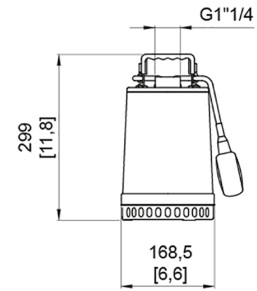
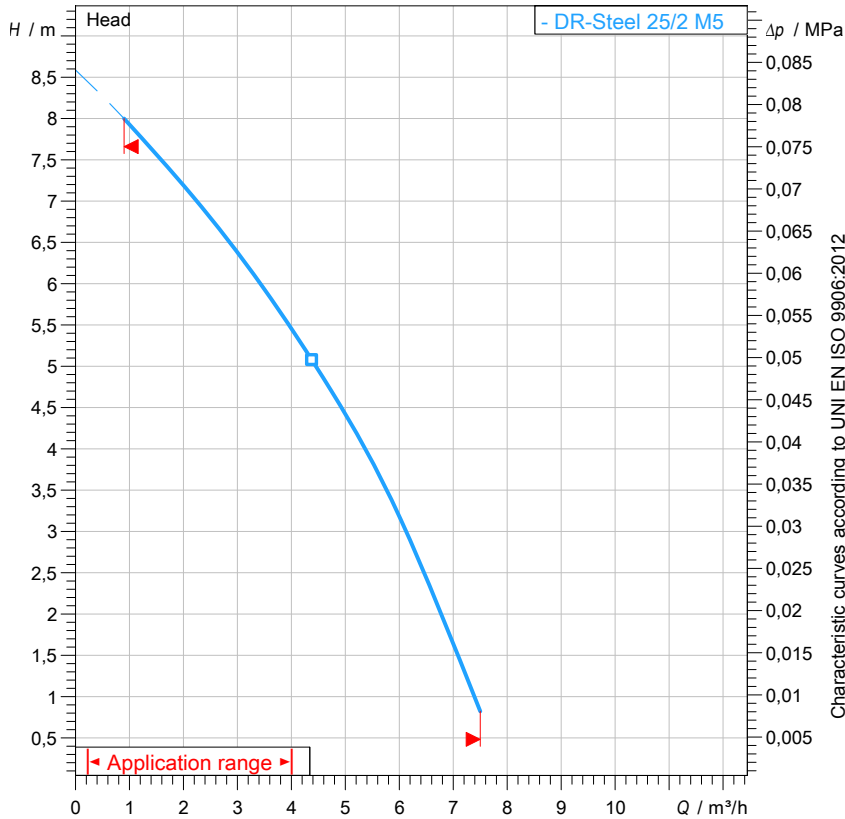
**1~ 50 Hz**

 [ mm  
[inch] ]

#### Pump

Series	Steel series
Pump name	DR-Steel 25 M5
Configuration	0 TG5H2300NN
Standard	EN 809:2009

#### Motor data

Rated voltage	230 V
Frequency	50 Hz
Motor phases	1~
Number of poles	2
Rated power P2	0,25 kW
Incoming power P1	0,50 kW
Rated current	2,3 A
rpm	2720 1/min
Efficiency	54,0 %
cos φ	0,98
Rated torque	1,0 Nm
Start	
Degree of protection	IP 68
Insulation class	F

#### Hydraulic

Type	DR (Multi-channel open)
Free passage	10 mm
Impeller type	Multi channel impeller
Max. hydraulic efficiency	
Suction	-
Discharge	G 1" 1/4 -
Curve tolerance	UNI EN ISO 9906:2012

#### Operating limits (standard pumps)

Max. ambient temperature	40 °C
Max. density treated liquid	1100 kg/m³
Max. immersion depth	10 m
pH treated liquid	6 ÷ 14
Max. start per hour (equally distributed)	30
Wet/dry use	WET
Max. acoustic pressure level	70 dB
Operating mode	S1 - Continuous use

#### Construction materials

Case	Stainless steel - AISI 304
Shaft	Stainless steel AISI 431
Hydraulic	Stainless steel - AISI 304
Impeller	Stainless steel - AISI 304
Screws	Stainless steel - Class A2-70
Gaskets	NBR
Strainer	Stainless steel - AISI 304

#### Construction features

Main cable	3G1
Cable length	5 mt - Shuko plug
Mechanical seals	1 in silicon carbide (SiC) and 1 in alumina graphite (AL)
Weight*	5,9 kg
Electrical variant	Thermal protection, capacitor and float switch (on the motor cover)

\* cable's weight not included



water solutions

# Data sheet DR-Steel 25 M5

**Steel**  
series

## Pump performance curves

1~ 50 Hz

Hydraulic type DR (Multi-channel open)		Impeller type Multi channel impeller		Free passage 10 mm	Discharge G 1" 1/4	Suction -
<b>DUTY POINT</b>						
Flow	Head	Shaft power P2	Hydraulic efficiency	Density 998,3 kg/m <sup>3</sup>	Viscosity 1,005 mm <sup>2</sup> /s	

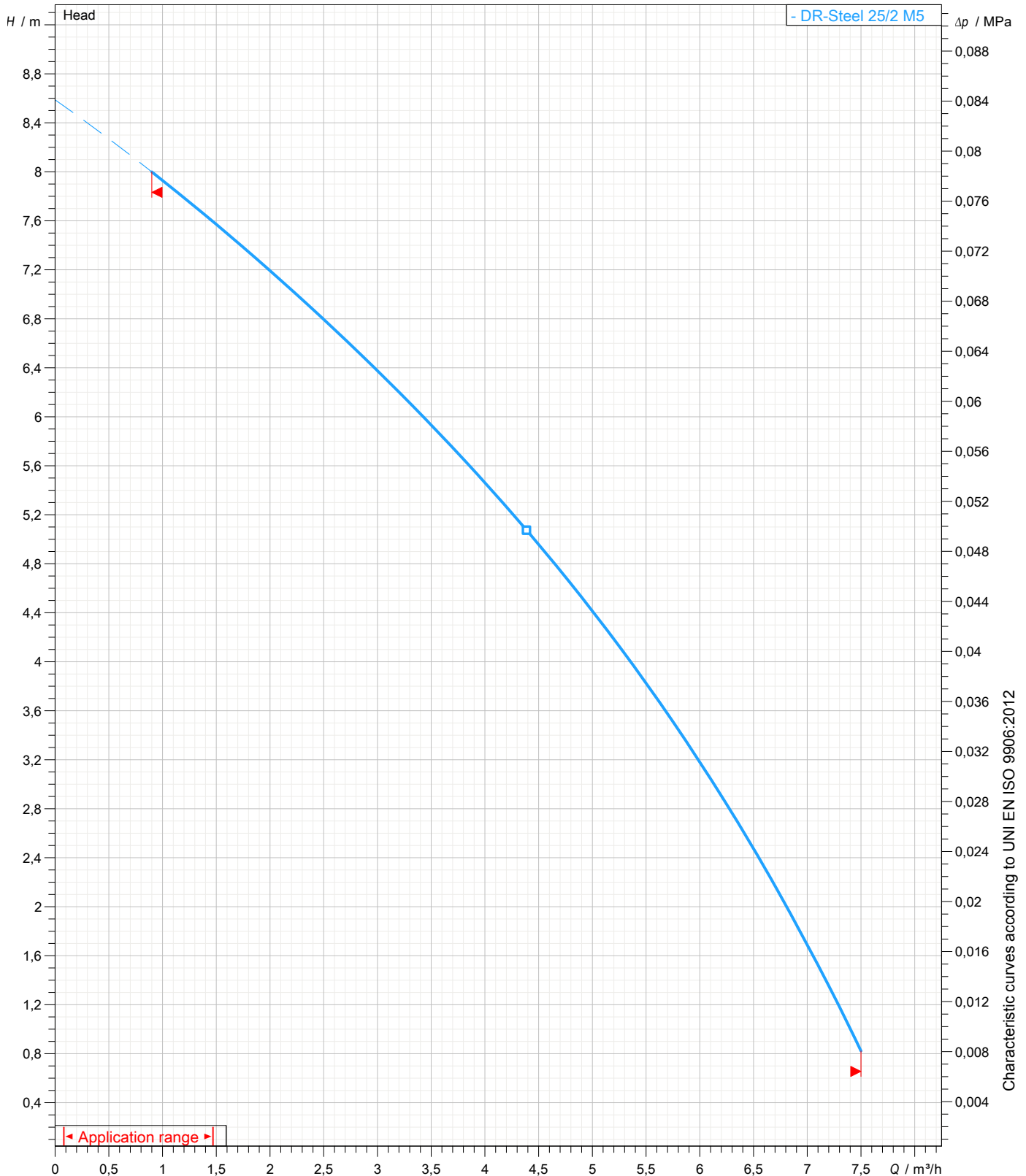



water solutions

# Data sheet DR-Steel 25 M5

**Steel**  
series

## Dimensional drawing

1~ 50 Hz

**Installation type** Free Installation

WET/DRY use: WET

Discharge: G 1" 1/4 -

Suction: -

Pressure rating (suction/discharge): -

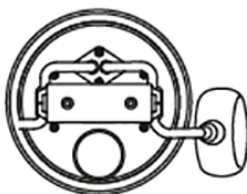
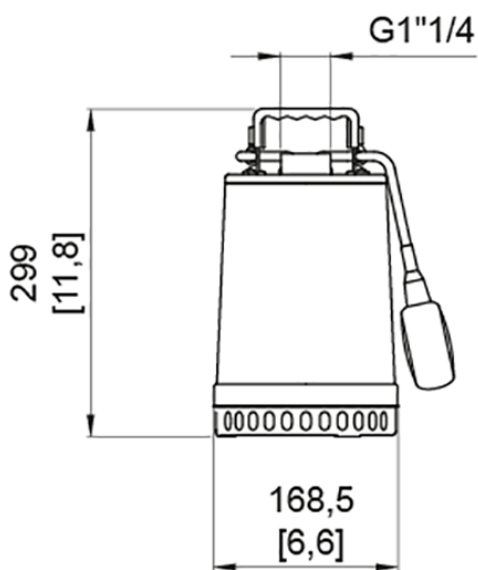

[ mm ]  
[ inch ]