



water solutions

Data sheet

DGO 75/2/G50H A1CT5



Technical specification

3~ 50 Hz

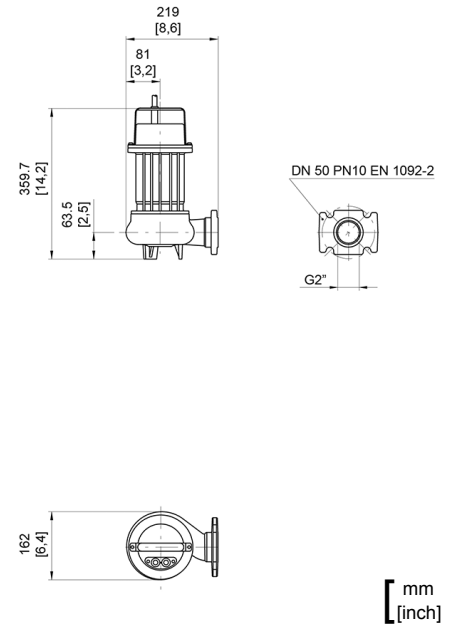
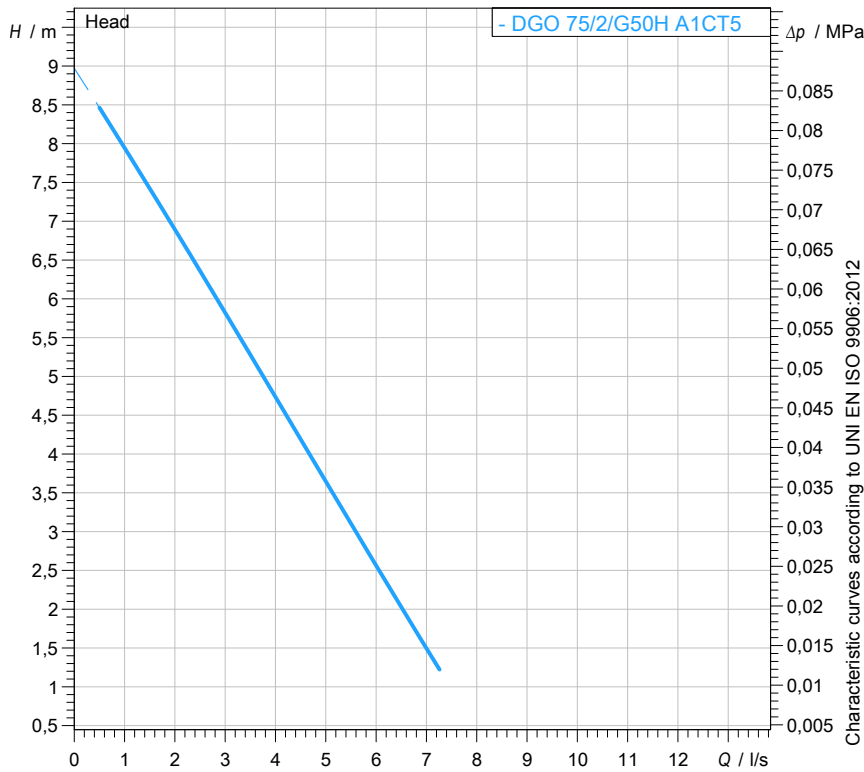

Pump

Series	O series
Pump name	DGO 75/2/G50H A1CT5
Configuration	NGNAB40540N00NN
Standard	EN 809:2009

Motor data

Rated voltage	400 V
Frequency	50 Hz
Motor phases	3~
Number of poles	2
Rated power P2	0,55 kW
Incoming power P1	0,80 kW
Rated current	1,4 A
rpm	2640 1/min
Efficiency	60,2 %
cos ϕ	0,85
Rated torque	2,0 Nm
Start	Direct starting
Degree of protection	IP 68
Insulation class	F

Hydraulic

Type	DG (Set-back Vortex)
Free passage	40 mm
Impeller type	Vortex impeller
Discharge	DN 50 - G2" EN 1092-2
Curve tolerance	UNI EN ISO 9906:2012

Operating limits (standard pumps)

Max. ambient temperature	40 °C
Max. density treated liquid	1100 kg/m ³
Max. immersion depth	20 m
pH treated liquid	6 ÷ 14
Max. start per hour (equally distributed)	30
Wet/dry use	WET
Max. acoustic pressure level	70 dB
Operating mode	S1 - Continuous use

Construction materials

Case	Cast iron EN-GJL 250
Shaft	Stainless steel - AISI 420
Hydraulic	Cast iron EN-GJL 250
Impeller	Cast iron EN-GJL 250
Painting/Coating	Bi-epoxy 80 μ m
Screws	Stainless steel - Class A2-70
Gaskets	NBR

Construction features

Cooling system	No cooling jacket
Main cable	4G1
Control cable	-
Cable length	5 mt
Mechanical seals	1 in silicon carbide (SiC) and 1 in alumina graphite (AL)
Additional drilling	-
Weight*	16,5 kg
Electrical variant	No electrical device equipped

* cable's weight not included



water solutions

Data sheet DGO 75/2/G50H A1CT5



Pump performance curves

3~ 50 Hz

Hydraulic type DG (Set-back Vortex)		Impeller type Vortex impeller		Free passage 40 mm	Discharge DN 50 - G2"	Suction -
DUTY POINT						
Flow	Head	Shaft power P2	Hydraulic efficiency	Density 998,3 kg/m ³	Viscosity 1,005 mm ² /s	

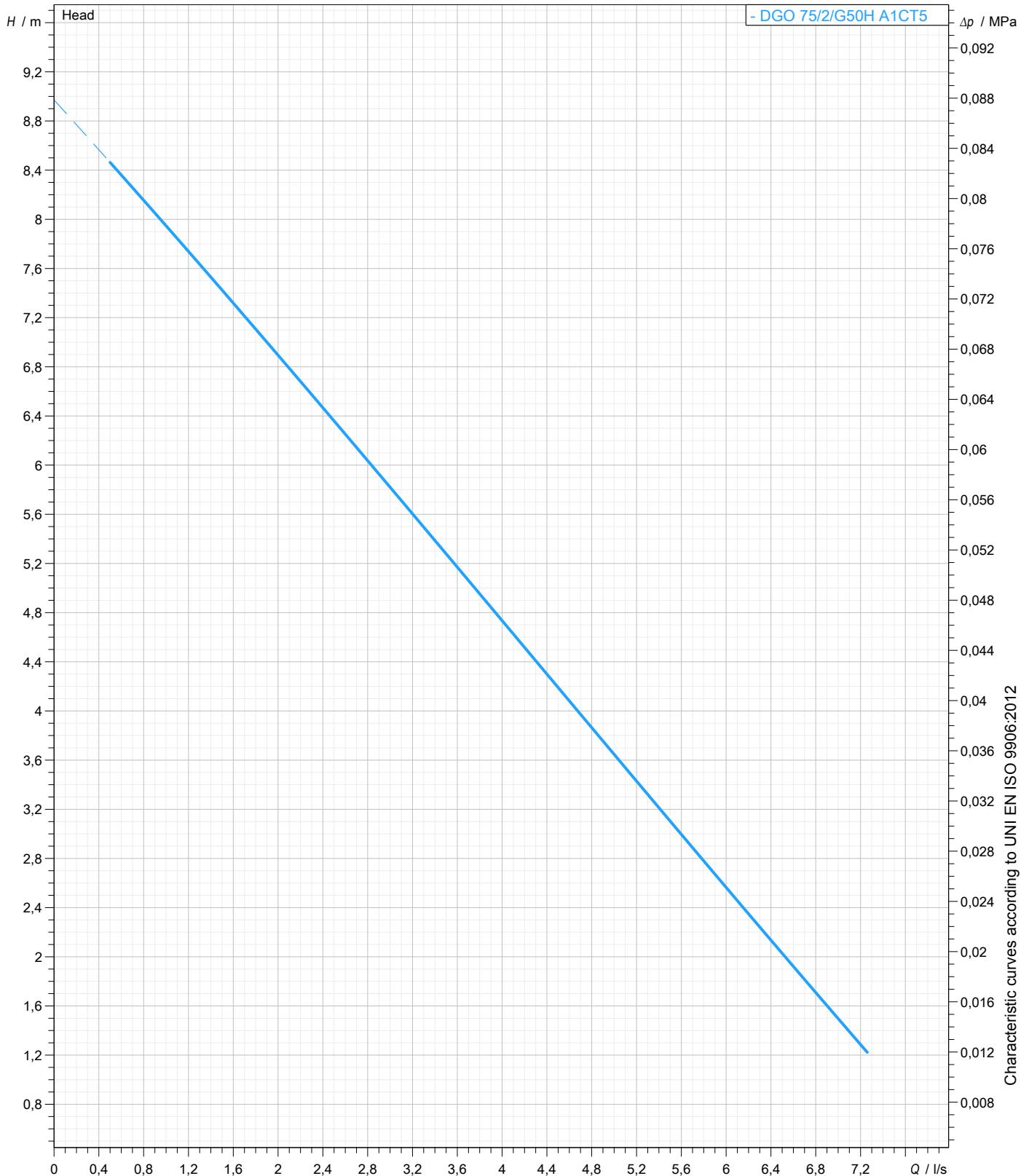

Characteristic curves according to UNI EN ISO 9906:2012



water solutions

Data sheet DGO 75/2/G50H A1CT5



Dimensional drawing

3~ 50 Hz

Installation type Installation with bottom coupling device - Vertical outlet + GTP

WET/DRY use: WET

Accessory * : DAC 32-50/G50V-G65V 3/4" EN+GTP (P)

Discharge: DN 50 - G2" EN 1092-2

Accessory code * : 9028.002

Pressure rating (suction/discharge): PN 10

* Accessory must be ordered separately

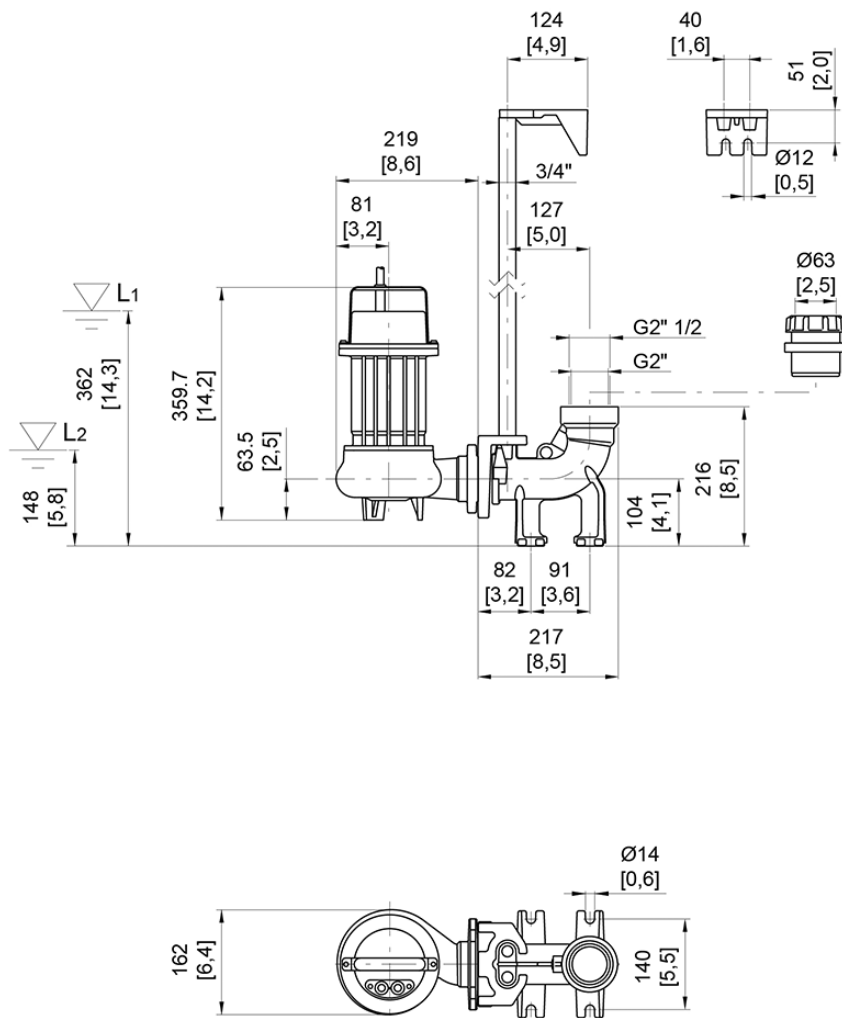

L1: Minimum operating level for continuous use
L2: Minimum operating level for discontinuous use

[mm]
[inch]