

aquaboost

iBoost F200, iBoost V200, iBoost F200-CAT 5, iBoost V200-CAT 5

Pump Description	Dim. 'A'	Overflow*
Aquaboost iBoost F200/V200	1282 mm	G 1/4
Aquaboost iBoost F200/V200-CAT 5	1299 mm	G 3/4

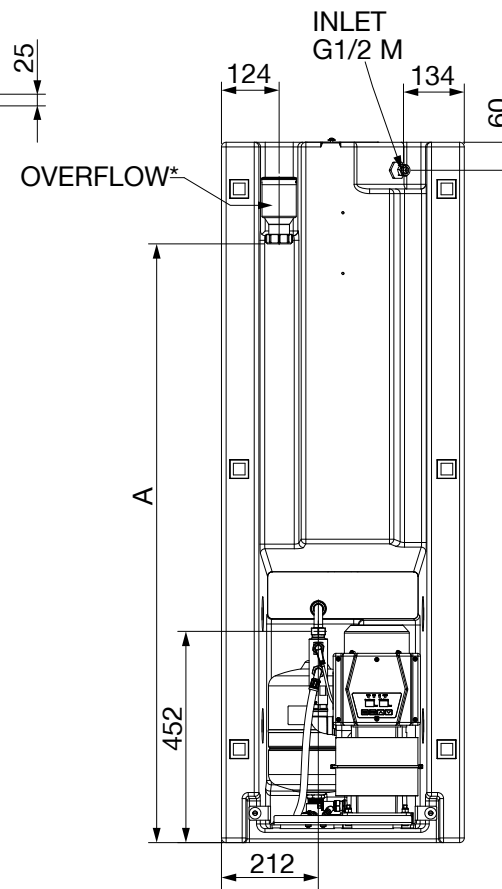
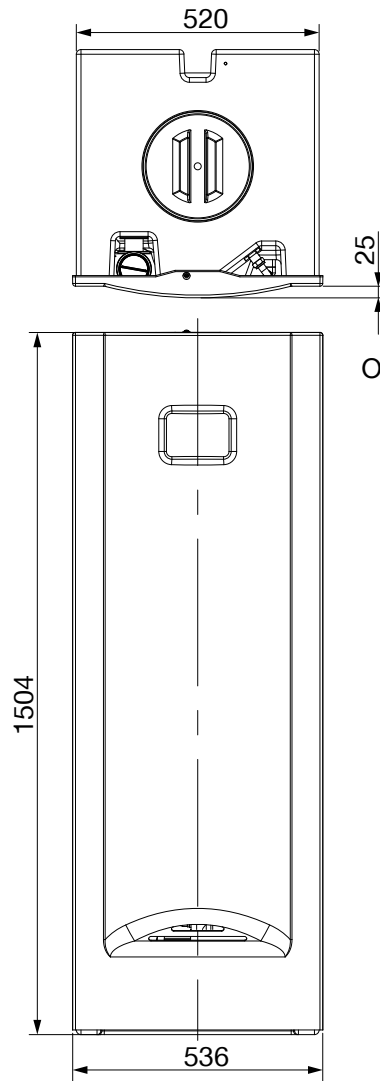
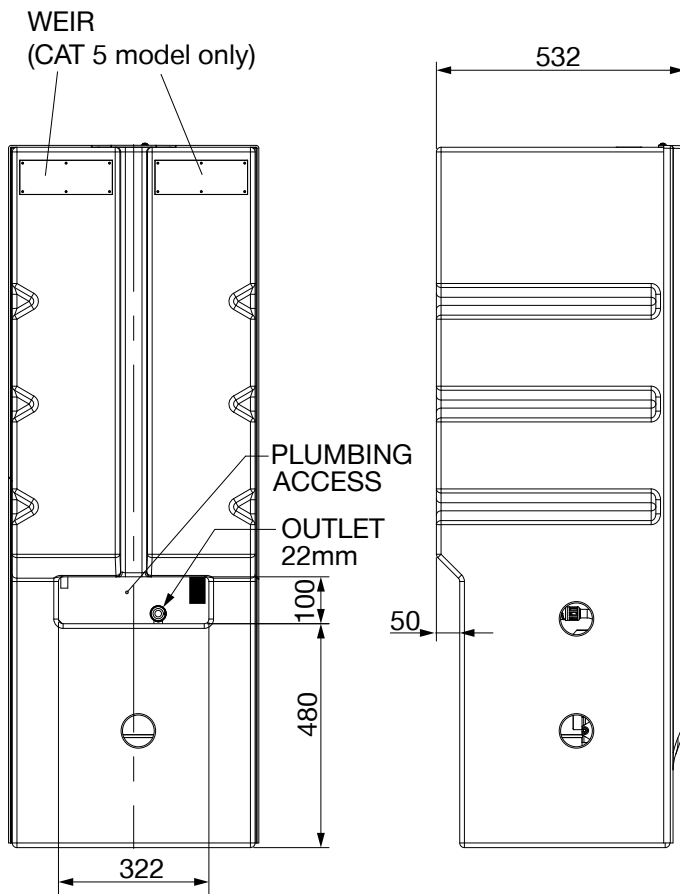

Dimensions in millimetres

For further advice on selecting the correct pump call
or e-mail info@stpumps.co.uk

Issue 2218/1

Stuart Turner Ltd own the copyright within this document. The document may be printed for personal use only. The document must not be altered, reproduced or utilised in any way without written permission from Stuart Turner Ltd, Henley-on-Thames, Oxfordshire, RG9 2AD, England.

Stuart Turner Ltd reserve the right to amend the document or product specifications in line with it's policy of continuous development.

pumpassist
HELPLINE +44 (0) 800 31 969 80