

aquaboost

iBoost

Ideally suited to high occupancy properties with multiple bathrooms and water using appliances.

Aquaboost iBoost provides a boosted cold water supply of up to 100 litres per minute and up to 4.5 bar pressure, with a typical performance of 60 litres per minute at 3.0 bar pressure.

This reliable compact system will sit neatly within any standard 600 mm kitchen larder cupboard or alongside other household white goods.

In addition to the standard iBoost CAT 3/4 model, the iBoost CAT 5 option features a weir overflow making it suitable for use in applications where the risk of backflow contamination from Category 5 fluids exists.

Both iBoost models are available with either fixed speed or variable speed pump controls.

The optional iBoost +200 extension tank allows the stored water capacity of an iBoost system to be increased to 400 litres.



Features

General

- Boosts cold water mains supply to 4.5 bar pressure
- Flow rates up to 100 l/min
- 200 litre capacity water storage tank with high flow fill valve
- Dry run protection
- Simple installation and set up
- Optional +200 litre water storage capacity extension tank
- Category 5 fluid risk options

iBoost F200

- Fixed speed pump control
- Quiet operation, typically 62 dB(A)

iBoost V200

- Programmable variable speed pump control
- Very quiet operation, typically 57 dB(A)

Application

iBoost F200 / iBoost V200

- Boosting cold mains water pressure and flow in larger domestic and light commercial applications

iBoost F200-CAT 5 / iBoost V200-CAT 5

- Boosting cold mains water pressure and flow in laboratories, stables, kennels, waste bin stores and wash down stations

iBoost +200 / iBoost +200-CAT 5

- Expanding the water storage capacity of an iBoost unit to meet high demand applications



iBoost F200

The iBoost F200 features a fixed speed pump control system capable of generating pressures of up to 4.5 bar and flow rates of up to 100 litres per minute.

- 200 litre capacity water storage tank with high flow fill valve
- Slim and compact design
- Control panel and status indicators
- Simple installation and set up
- Dry run protection



iBoost V200

The iBoost V200 features the same capabilities as the F200 unit with the added benefits of an advanced variable speed pump control system. This enables the unit to supply water at a constant programmable water pressure as the water demands on the system change.

- Automatically adjusts pump speed to meet actual water demand and maintain stable water pressure
- Provides a 'soft start' when outlets are opened
- Optimises pump efficiency, power consumption and lifespan
- Very quiet operation



iBoost +200

The iBoost +200 water storage extension tank effectively doubles the capacity of an iBoost F200 or V200 unit from 200 litres to 400 litres.

- Additional 200 litre capacity water storage tank with high flow fill valve
- Extended run times, reduced chances of running dry
- Simple installation, connection to main iBoost unit tank can be made through the tank sides with the kit supplied

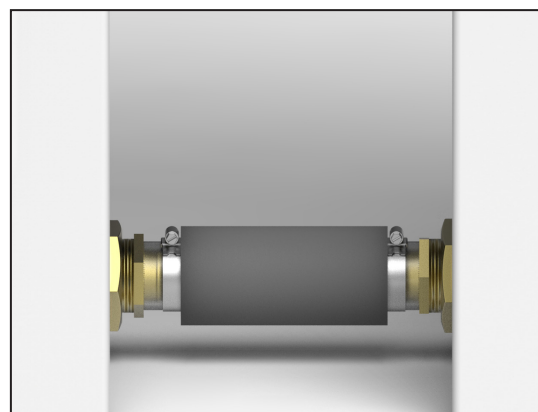

iBoost CAT 5

All standard iBoost units are rated for CAT 3/4 fluids and are also available as a CAT 5 version making them suitable for use in high risk Category 5 fluid applications.

- Type AB air gap
- Weir overflow



iBoost Model		F200 46668	F200-CAT 5 46677	V200 46711	V200-CAT 5 46713	+200 46712	+200-CAT 5 46714
General	Guarantee	3 years					
	WRAS approval	1705346	-	Approved materials	-	Approved materials	-
Features	Pump control system	Fixed speed, pressure switch		Variable speed, pressure transducer		-	-
	Control interface	Standard controls		Programmable controls**		-	-
	Dry run protection	✓		✓		-	-
	Noise	62 dB(A)		57 dB(A)		-	-
	Fluid risk compatibility	CAT 3, CAT 4	CAT 5	CAT 3, CAT 4	CAT 5	CAT 3, CAT 4	CAT 5
	Air gap	Type AF	Type AB	Type AF	Type AB	Type AF	Type AB
	Pressure vessel	8 litres		8 litres		-	-
Performance	Maximum head (nominal closed valve)	4.5 bar (450 kPa)				-	-
	Maximum flow rate	100 l/min				-	-
	Maximum inlet pressure (tank fill valve)	7 bar (700 kPa)				-	-
	Maximum static outlet head	15 metres				-	-
	Ambient air temperature (Min - Max)	4 °C - 30 °C				4 °C - 30 °C	
Water tank	Nominal size	220 litres					
	Usable capacity	200 litres					
	Fill rate	20 l/min*					
Connections	Cold water inlet	G ½ male				G ½ male	
	Cold water outlet (pump)	G ¾ male				-	-
	Cold water outlet (flexible hose)	G ¾ female x 22 mm push-in (220 mm long)				-	-
	Overflow (compression fitting)	G 1¼	G ¾	G 1¼	G ¾	G 1¼	G ¾
Materials	Break tank	Polyethylene				Polyethylene	
	Front panel	Acrylic capped ABS				Acrylic capped ABS	
	Pump body	Brass / stainless steel				-	-
	Pump impeller	Stainless steel				-	-
Pump	Pump type	Multistage centrifugal				-	-
	Duty rating	Continuous (S1)				-	-
	Pump motor type	1 phase induction (thermal trip, auto reset)		3 phase induction (current overload sensor)		-	-
Electrical	Power supply / phase / frequency	230 V a.c. / 1 / 50 Hz				-	-
	Current (full load)	5.5 Amps		6.8 Amps		-	-
	Power consumption	1260 Watts		996 Watts		-	-
	Fuse rating	10 Amps				-	-
	Power cable (pre-wired)	3.0 metres				-	-
Physical	Depth	529 mm				-	-
	Width	536 mm				-	-
	Height	1504 mm				-	-
	Empty weight	55 Kg		56 Kg		35 Kg	
	Filled weight	255 Kg		256 Kg		235 Kg	

*Assumes 1 bar inlet pressure.

**Variable speed pre-set to 3.0 bar, adjustable in 0.1 bar increments.

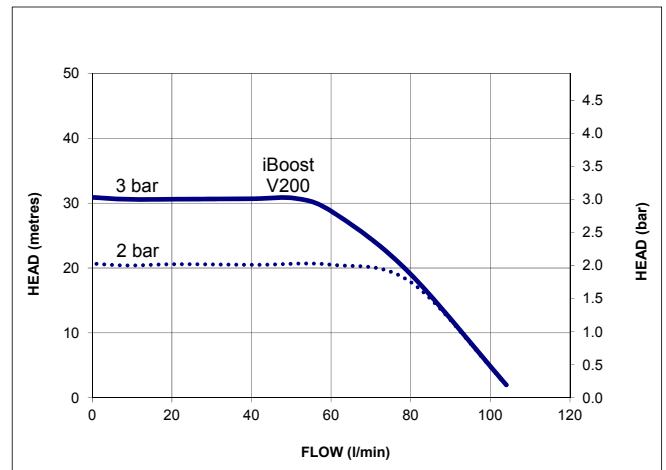
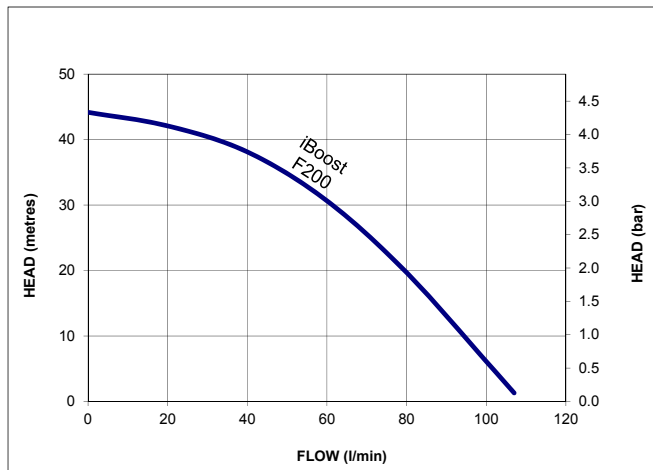

For further advice on selecting the correct pump call
or e-mail info@stpumps.co.uk

pumpassist
HELPLINE +44 (0) 800 31 969 80

iBoost F200/V200/CAT 5

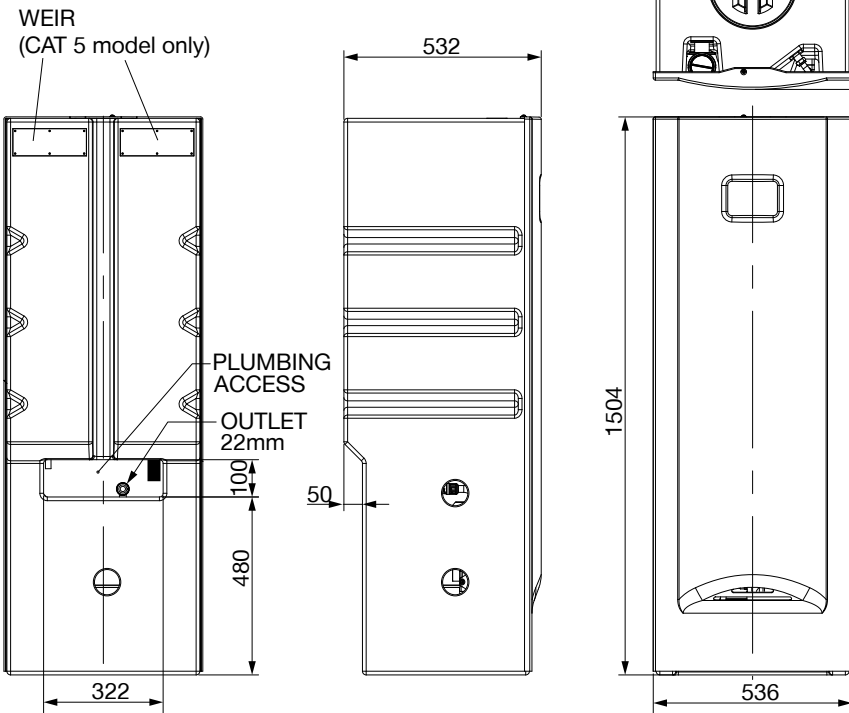

Pump Description	Dim. 'A'	Overflow*
iBoost F200/V200	1282 mm	G 1¼
iBoost F200/V200 CAT 5	1299 mm	G ¾

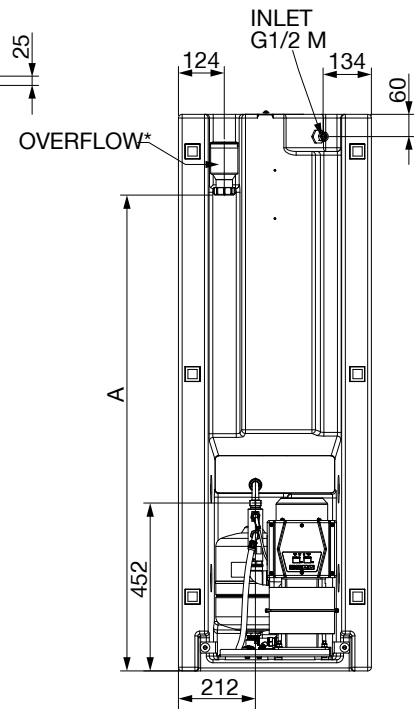

iBoost +200/+200-CAT 5

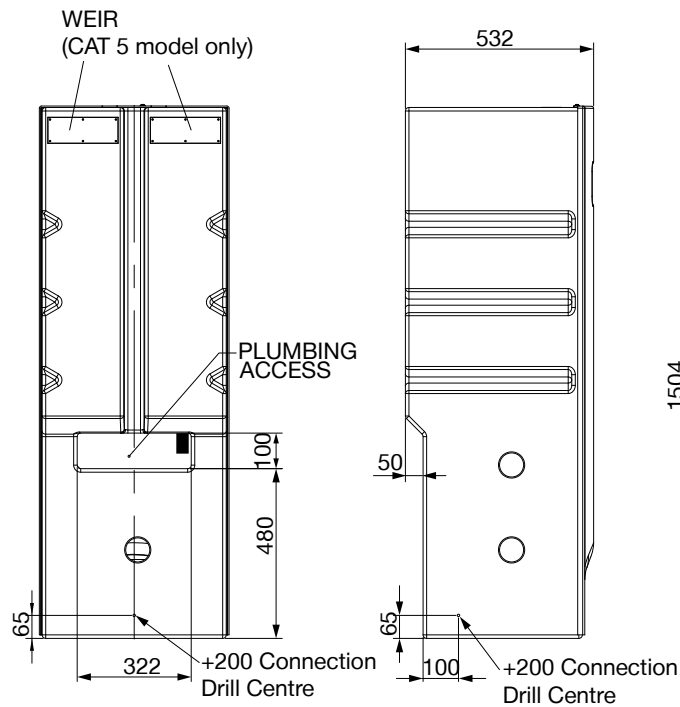

Pump Description	Dim. 'A'	Overflow*
iBoost +200	1282 mm	G 1¼
iBoost +200-CAT 5	1299 mm	G ¾

