

stuart

Installation, Operation & Maintenance Instructions

Please leave this instruction booklet with the owner as it contains important guarantee, maintenance and safety information



Read this manual carefully before commencing installation.

This manual covers the following products:

CH 7-9
Pt. No. 46372

CH 9-9
Pt. No. 46374

CH 12-14
Pt. No. 46379

FOR POSITIVE HEAD APPLICATIONS ONLY

50 Hz



PRODUCT DESCRIPTION

Electric motor driven centrifugal pump.

APPLICATION

The CH range of centrifugal pumps are designed to pump clean fresh water. Other clean, non aggressive, non explosive liquids with similar characteristics to water may be pumped. Consult Stuart Turner for advice on such applications.

The pumps can be used for pressure boosting, fluid transfer and distribution. They are suitable for flooded suction applications. Alternatively a maximum suction lift of 4.6 metres is permitted when using a Stuart footvalve/strainer.



- **This pump set must not be used for any other application without the written consent of Stuart Turner Limited.**
- **Do not connect this pump to the mains water supply.**
- **The use of this product requires experience with and knowledge of the product.**
- **Persons with reduced physical, sensory or mental capabilities must not use this product, unless they are under supervision or have been instructed in the use of the product by a person responsible for their safety.**
- **Children must not use or play with this product.**

Please read installation details carefully as they are intended to ensure this product provides long, trouble free service. Failure to install the unit in accordance with the installation instructions will lead to invalidation of the warranty.

STORAGE

If this product is not to be installed immediately on receipt, ensure that it is stored in a dry, frost and vibration free location in its original packaging.

CONTENTS

	Page
Checklist	3
Important Facts - read before commencing installation	4
Location	5
Electrical Installation	6
Plumbing	9
Technical Specification	10
Trouble Shooting	11
Guarantee	12

Cont ...

CHECKLIST

IMPORTANT: With the pump removed from its packaging check for any damage prior to installation. If any damage is found contact Stuart Turner Ltd within 24 hours of receipt.

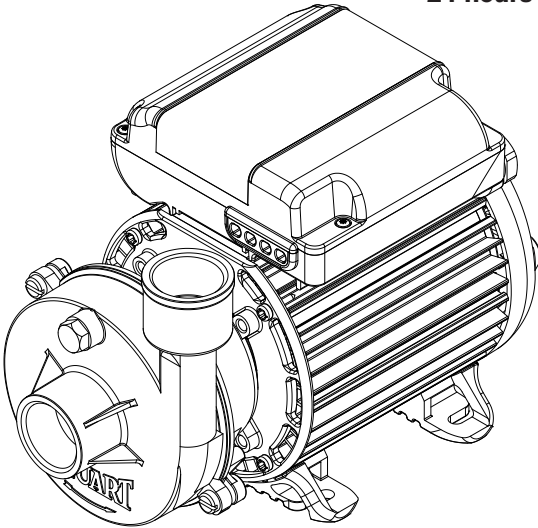

Fig. 1

Your product may vary slightly from the picture above.

1 IMPORTANT FACTS: READ BEFORE COMMENCING PUMP INSTALLATION

A. Water storage capacity.

- 1.11 The water storage capacity must be sufficient to meet the flow rates required by the pumped equipment and any other water using fittings and appliances, which may be operated simultaneously. **DO NOT RUN PUMP DRY.**
- 1.12 Ensure the pump is primed as described in the priming section before starting, damage to the shaft seal will result otherwise. See Section 4 - Plumbing.

B. Water temperature

The water entering the pump must be controlled as follows:

- 1.13 The maximum allowable water temperature is 80 °C.
- 1.14 The minimum allowable water temperature is 4 °C.
- 1.15 **Ambient temperature:** The pump must be sited in a location where the maximum ambient temperature does not exceed 40 °C.
- 1.16 **DO NOT** fit a pump if the hot water is heated via a method whereby the water temperature cannot be controlled, such as solar or solid fuel you must consult the PumpAssist team on +44 (0) 800 31 969 80.

C. Pipework - general

- 1.17 **Pipework design:** Care should be taken in the design of pipework runs to minimize the risk of air locks e.g. use drawn bends rather than 90° bends.



- 1.18 **DO NOT** allow contact with oil or cellulose based paints, paint thinners or strippers, acid based descalents or aggressive cleaning agents.

D. Plumbing installation regulations

- 1.19 The plumbing installation must be installed by a qualified person and in accordance with local regulations.

E. Electrical/installation regulations

- 1.20 The electrical installation must be installed by a qualified person and in accordance with local regulations.
- 1.21 Check the mains voltage and frequency corresponds to the values on the pump rating plate.

2 LOCATION - GENERAL



- 2.11 **Access:** For emergencies and maintenance the pump must be easily accessible.
- 2.12 **Protection:** The pump must be located in a dry position, frost free and protected from freezing.
- 2.13 **Ventilation:** Ensure an adequate air flow to cool the pump. Separate the pump from other appliances that generate heat. An 80 mm (3 ") air gap must be maintained around the pump.
- 2.14 **Safety:** The motor casing can become very hot under normal operating conditions. Care must be taken to ensure it cannot be touched during operation.
- 2.15 **Water retention:** Site the pump in a location where in the unlikely event of a water leak, any spillage is contained or routed to avoid electrics or areas sensitive to water damage.
- 2.16 **Pump position:** The pump must be positioned on its mounting feet and as close to the water source as possible.
- 2.17 **Mounting foot securing:** This pump is fitted with plastic feet. If there is a requirement to secure the pump via the feet, the following points should be noted.
The pump should be mounted only in the horizontal position.

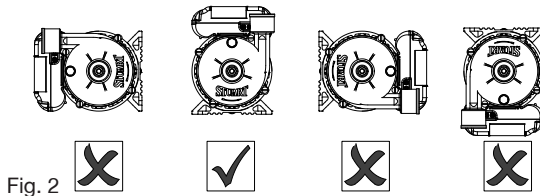

Fig. 2

The mounting bolts used to secure the pump must be fitted with a plain washer to distribute clamping load evenly across load bearing face of foot (not supplied).

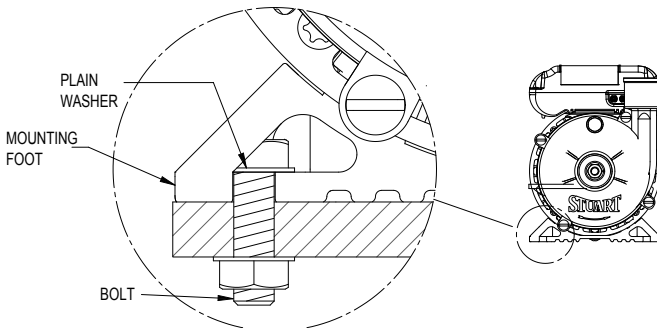

Fig. 3

3 ELECTRICAL INSTALLATION / EARTHING



- 3.11 **Regulations:** The electrical installation must be carried out in accordance with the current local regulations by a qualified person.
- 3.12 **Safety:** In the interests of electrical safety a 30 mA residual current device (**R.C.D. not supplied**) should be installed in the supply circuit. This may be part of a consumer unit or a separate unit.
- 3.13 Before starting work on the electrical supply ensure power supply is isolated.
- 3.14 **DO NOT** allow the supply cord to contact hot surfaces, including the motor shell, pump body or pipework. The cord should be safely routed and secured by cable clips.
- 3.15 **Earthing:** This appliance must be earthed via the supply cord, which must be correctly connected to the earth point located in the terminal box.
- 3.16 **Connections:** The pump must be permanently connected to the fixed wiring of the mains supply using the factory fitted supply cord, via a dedicated double pole switched fused spur off the ring main.
- 3.17 **Wiring of connection unit:**



WARNING: This appliance must be earthed.

This product range must be permanently connected to fixed wiring and is provided with a set of terminals which allow the connection of a flexible supply cord.

Select a cord and fuse size based on the motor full load current and the surrounding conditions in accordance with 60335-1.

For information on cable fitting and connection, consult the wiring diagram and cable gland and supply cord fitting instructions.

3.18 Cable Gland & Supply Cord Fitting Instructions

The cable gland assembly Fig. 6 (items 1 & 2) provides the necessary protection against ingress of solid objects and moisture as well as providing cable retention. Assembly instructions are as follows: -

1. Ensure selected cable sheath diameter is within the permitted range (6.5 to 9.5 mm).
2. Strip and prepare the cable sheath and insulators as shown in Fig. 4.
3. Disassemble cable gland as shown in Fig. 6 and insert cable into position ensuring 'O'-ring (item 2) is placed over the cable before the clamping insert (item 1) is tightened.
4. Consolidate the stranded conductor ends by twisting and shape the earth conductor as shown in Fig. 5 (item 3).
5. Remove earth terminal post clamping components and assemble as shown in Fig. 5 ensuring shaped conductor is orientated as shown and all strands of the conductor are clamped between the washers.
6. Insert and secure live and neutral conductors ensuring all conductor strands are clamped.
7. Confirm cable routing is as shown in Fig. 6 and assemble and secure terminal box lid.

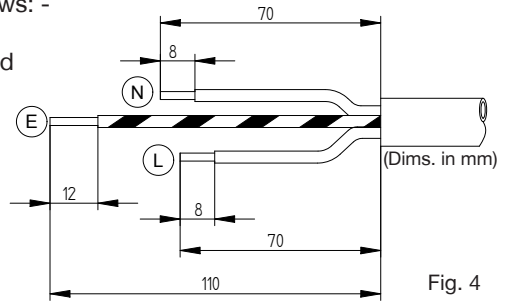

Fig. 4

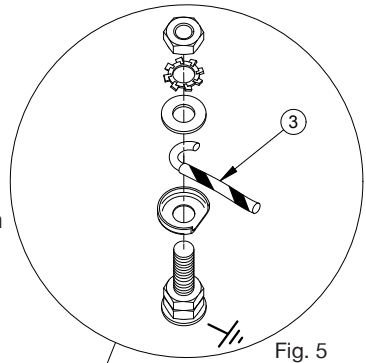

Fig. 5

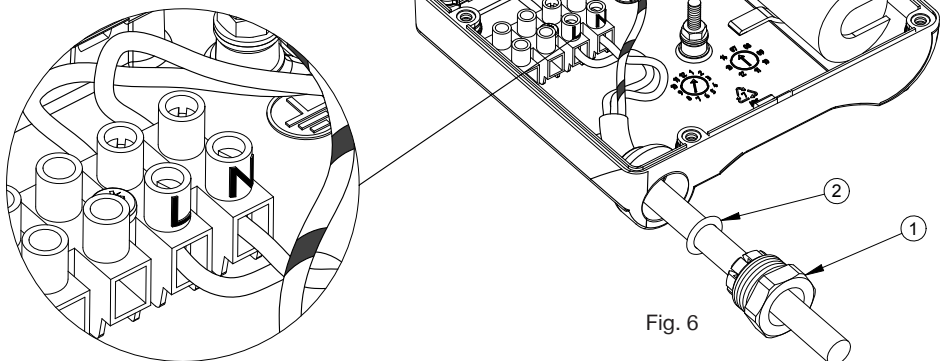
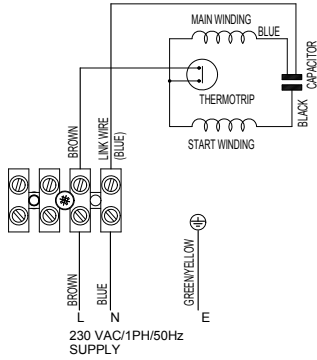

Fig. 6

Cont ...

3.19 Wiring diagram:



3.20 **Fuse:** All models should use 5 Amp fuse.

3.21 **Supply cord replacement:**



The internal wiring within the terminal box is routed and secured to ensure compliance with the electrical standard EN 60335-1. It is essential that prior to any disturbance of this internal wiring, all cable routing and securing details are carefully noted to ensure re-assembly to the same factory pattern is always maintained.

4 PLUMBING

- 4.11 **Pipework:** For optimum performance pipework use 22 mm dia., 15 mm can be used but will result in reduced pump performance.
- 4.12 **Isolating valves:** Separate isolating valves (non restrictive) must be fitted to allow easy pump service.
- 4.13 Although this pump is not self priming, once fitted with a footvalve and strainer it can be used to draw water from a storage tank below the pump position, or without a footvalve and stainer, from a tank above the pump position.

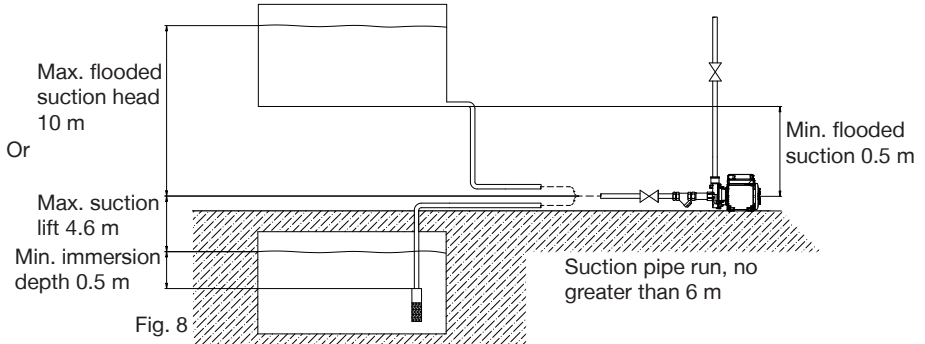

- 4.14 **System flushing:** The pipework system should be flushed out prior to the pump being connected to ensure any contaminants/chemical residues and foreign bodies are removed from elsewhere in the system.

4.15 Priming:



Never operate pump with inlet and/or outlet isolating valves in the closed position. Damage will occur!

The pump must be primed (filled with water) before starting.

4.16 Flooded suction conditions:

Turn on the isolating valves.

- Loosen vent plug and allow an even flow of water this may take a few seconds.
- Re-seal vent plug, nipping tight.
The pump is now ready to start.

4.17 Suction lift conditions:

Turn on isolating valves

- Loosen vent plug.
- Fill the pump head and suction pipe with water from the discharge port until filled with water.
- Re-seal vent plug.

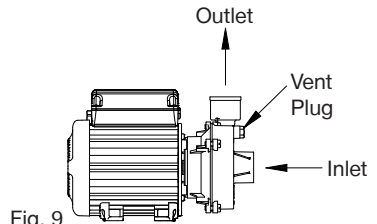

4.18 Maintenance:

This product is maintenance free for its life, however it is a mechanical product and will eventually show signs of wear. Spare parts are available, for more information phone the Stuart Turner PumpAssist team on +44 (0) 800 31 969 80.

5 TECHNICAL SPECIFICATION

Pump Model		CH 7-9 50 Hz 46372	CH 9-9 50 Hz 46374	CH 12-14 50 Hz 46379
General	Guarantee	2 years		
Features	Pump type	Centrifugal		
	Mechanical seal	EPDM / PTFE / Al. Oxide		
	Priming vent plug	✓	✓	✓
Materials	Pump body	Brass		
	Impeller	Plastic		
Performance	Maximum head (closed valve)	8.8 metres	9.1 metres	14.2 metres
	Performance @ 60 l/min	7.8 metres	8.1 metres	13.1 metres
	Performance @ 120 l/min	3.1 metres	5.3 metres	11.0 metres
	Maximum flow	132 l/min	164 l/min	210 l/min
	Minimum static inlet pressure	0.05 bar (0.5 metres)		
	Maximum static inlet pressure	1 bar (10 metres)		
	Maximum viscosity	50 secs redwood no. 1 9.5 centistokes		
	Maximum working pressure*	600 kPa (6 bar)		
	Maximum ambient air temperature	40 °C		
	Min / Max water temperature	Min 4 °C / Max 80 °C		
	Suction lift**	4.6 metres		
Connections	Pump connections	G 1 female		
Motor	Type	Induction, auto-reset thermal trip		
	Duty rating	Continuous (S1)		
Electrical	Power supply / phase / frequency	230 V a.c. / 1 / 50 Hz		
	Current (full load)	1.0 Amps	1.5 Amps	2.8 Amps
	Power consumption	230 Watts	330 Watts	595 Watts
	Fuse rating	5 Amps		
Physical	Enclosure protection	IP44		
	Length	242 mm		277 mm
	Width	131 mm		
	Height (excluding hoses)	170 mm		
	Weight (including fittings)	5.3 Kg	5.7 Kg	7.6 Kg

Stuart Turner reserve the right to amend the specification in line with its policy of continuous development of its products.

*Note: The maximum pressure that can be applied to the pump under any installation conditions.

**Note: With footvalve fitted.

5.11 **Noise:** The equivalent continuous A-weighted sound pressure level at a distance of 1 metre from the pump does not exceed 70 dB(A).

6 TROUBLE SHOOTING GUIDE

Symptoms	Probable Cause	Recommended Action
Pump will not start.	Electrical supply. Integral motor thermotrip activated.	Check power to motor. Check the correct fuse is being used/fuse. Check circuit breaker is set. Wait for thermotrip to auto-reset and check that duty point and run time is within specification.
Pump runs, but no liquid is pumped.	Air locked No liquid supply. Connections reversed. No flooded suction.	Bleed pipework and pump to clear air. Check the supply valves are turned on. Check outlet not restricted or blocked. Check liquid connections are on the right way round. Check the pump has a flooded suction and is primed. If a suction lift exists fit a Stuart footvalve/strainer and ensure suction is airtight. Prime the pump and suction pipe (see plumbing section).

- 6.11 **Environment protection:** Your appliance contains valuable materials which can be recovered or recycled.
At the end of the products' useful life, please leave it at an appropriate local civic waste collection point.

8 YOUR 2 YEAR GUARANTEE

Congratulations on purchasing a Stuart Turner pump.

We are confident this pump will provide many years of trouble free service as all our products are manufactured to the very highest standard.

All Stuart Pumps are guaranteed to be free from defects in materials or workmanship for 2 years from the date of purchase.

Within the guarantee period we will repair, free of charge, any defects in the pump resulting from faults in material or workmanship, repairing or exchanging the whole unit as we may reasonably decide.

Not covered by this guarantee: Damage arising from incorrect installation, improper use, unauthorised repair, normal wear and tear and defects which have a negligible effect on the value or operation of the pump.

Reasonable evidence must be supplied that the product has been purchased within the guarantee term prior to the date of claim (such as proof of purchase or the pump serial number).

This guarantee is in addition to your statutory rights as a consumer. If you are in any doubt as to these rights, please contact your local Trading Standards Department.

In the event of a claim please telephone **'PumpAssist'** or return the pump and flexible hoses with the accessories removed e.g pipes etc. If you have any doubt about removing a pump, please consult a professional.

+44 (0) 800 31 969 80

Proof of purchase should accompany the returned unit to avoid delay in investigation and dealing with your claim.

You should obtain appropriate insurance cover for any loss or damage which is not covered by Stuart Turner Ltd in this provision.

Please record here for your records.

TYPE NO.	SERIAL NO.	DATE PURCHASED

NOTES

NOTES

NOTES



DECLARATION OF CONFORMITY

2006/42/EC

BS EN ISO 12100-1, BS EN ISO 12100-2, BS EN 809

2014/35/EU

BS EN 60335-1, BS EN 60335-2-41

2014/30/EU

BS EN 55014-1, BS EN 55014-2, BS EN 55022, BS EN 61000-3-2, BS EN 61000-3-3,
BS EN 61000-4-2, BS EN 61000-4-3, BS EN 61000-4-4, BS EN 61000-4-5, BS EN 61000-4-6,
BS EN 61000-4-11

1999/519/EC

BS EN 62233

2011/65/EU

IT IS HEREBY CERTIFIED THAT THE STUART ELECTRIC MOTOR DRIVEN PUMP AS SERIAL NUMBER BELOW, COMPLIES WITH THE ESSENTIAL REQUIREMENTS OF THE ABOVE E.E.C. DIRECTIVES.



RESPONSIBLE PERSON
AND MANUFACTURER

STUART TURNER LIMITED
HENLEY-ON-THAMES, OXFORDSHIRE
RG9 2AD ENGLAND.

Signed.....  Technical Director

Stuart Turner are an approved company to BS EN ISO 9001:2008



Stuart Turner Ltd, Henley-on-Thames, Oxfordshire RG9 2AD ENGLAND
Tel: +44 (0) 1491 572655, Fax: +44 (0) 1491 573704
info@stpumps.co.uk www.stuart-turner.co.uk