

stuart

Installation, Operation & Maintenance Instructions

Please leave this instruction booklet with the owner as it contains important guarantee, maintenance and safety information

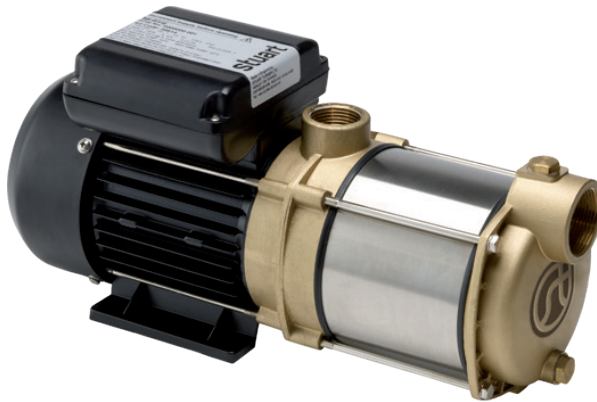

Read this manual carefully before commencing installation.

This manual covers the following products suitable for 230/1/50 supply.

Multistage CH4-30
Pt. No. 46553

Multistage CH4-50
Pt. No. 46555

Multistage CH4-40
Pt. No. 46554

Multistage CH4-60
Pt. No. 46556

50 Hz



PRODUCT DESCRIPTION

Electric motor driven centrifugal pump.

APPLICATION

These self priming centrifugal pumps are designed to pump clean fresh water and can be used for pressure boosting, fluid transfer and distribution.

Inlet pressures to the pump and ambient temperatures must not exceed the values given in the technical specifications.



- **This pump set must not be used for any other application without the written consent of Stuart Turner Limited.**
- **Do not connect this pump to the mains water supply.**
- **The use of this product requires experience with and knowledge of the product. Persons with reduced physical, sensory or mental capabilities must not use this product, unless they are under supervision or have been instructed in the use of the product by a person responsible for their safety.**
- **Children must not use or play with this product.**

Please read installation details carefully as they are intended to ensure this product provides long, trouble free service. Failure to install the unit in accordance with the installation instructions will lead to invalidation of the warranty.

STORAGE

If this product is not to be installed immediately on receipt, ensure that it is stored in a dry, frost and vibration free location in its original packaging.

CONTENTS

	Page
Checklist	3
Important Facts - read before commencing installation	4
Location	5
Electrical Installation	6
Plumbing	8
Technical Specification	9
Trouble Shooting	10
Guarantee	11

CHECKLIST

IMPORTANT: With the pump removed from its packaging check for any damage prior to installation. If any damage is found contact Stuart Turner Ltd within 24 hours of receipt.

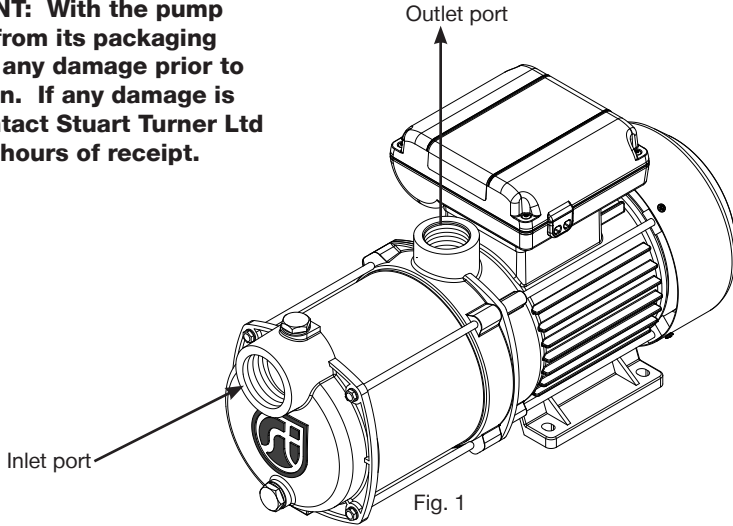

Your product may vary slightly from the picture above.

1 IMPORTANT FACTS: READ BEFORE COMMENCING PUMP INSTALLATION

A. Water storage capacity.

- 1.11 The water storage capacity must be sufficient to meet the flow rates required by the pumped equipment and any other water using fittings and appliances, which may be operated simultaneously. **DO NOT RUN PUMP DRY.**
- 1.12 Ensure the pump is primed as described in the priming section before starting, damage to the shaft seal will result otherwise. See Section 4 - Commissioning.

B. Water temperature

The water entering the pump must be controlled as follows:

- 1.13 The maximum allowable water temperature is 65 °C.
- 1.14 The minimum allowable water temperature is 4 °C.
- 1.15 **Ambient temperature:** The pump must be sited in a location where the maximum ambient temperature should not exceed 40 °C continuous or 50 °C intermittent.
- 1.16 **DO NOT** fit a pump if the hot water is heated via a method whereby the water temperature cannot be controlled, such as solar or solid fuel you must consult the PumpAssist team on +44 (0) 800 31 969 80.

C. Pipework - general

- 1.17 **Pipework design:** Care should be taken in the design of pipework runs to minimize the risk of air locks e.g. use drawn bends rather than 90° bends.



- 1.18 **DO NOT** allow contact with oil or cellulose based paints, paint thinners or strippers, acid based descalents or aggressive cleaning agents.

D. Plumbing installation regulations

- 1.19 The plumbing installation must be installed by a qualified person and in accordance with local regulations.

E. Electrical/installation regulations

- 1.20 The electrical installation must be installed by a qualified person and in accordance with local regulations.
- 1.21 Check the mains voltage and frequency corresponds to the values on the pump rating plate.

2 LOCATION - GENERAL



- 2.11 **Access:** For emergencies and maintenance the pump must be easily accessible.
- 2.12 **Protection:** The pump must be located in a dry position, frost free and protected from freezing.
- 2.13 **Ventilation:** Ensure an adequate air flow to cool the pump. Separate the pump from other appliances that generate heat. An 80 mm (3 ") air gap must be maintained around the pump.
- 2.14 **Safety:** The motor casing can become very hot under normal operating conditions. Care must be taken to ensure it cannot be touched during operation.
- 2.15 **Water retention:** Site the pump in a location where in the unlikely event of a water leak, any spillage is contained or routed to avoid electrics or areas sensitive to water damage.
- 2.16 **Pump position:** The pump must be positioned on its mounting feet and as close to the water source as possible.
- 2.17 **Mounting foot securing:** This pump is fitted with cast feet. If there is a requirement to secure the pump via the feet, the following points should be noted.
The pump should be mounted only in the horizontal position.

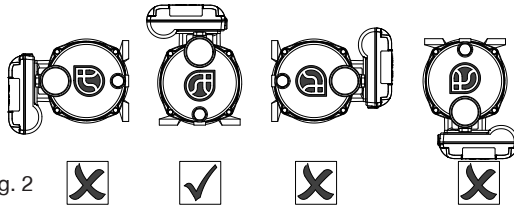

Fig. 2

The mounting bolts used to secure the pump must be fitted with a plain washer to distribute clamping load evenly across load bearing face of foot (not supplied).

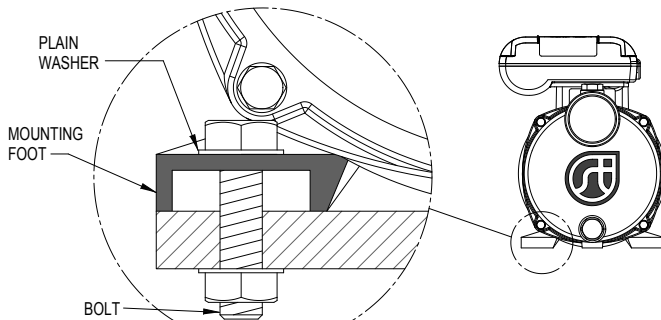

Fig. 3

3 ELECTRICAL INSTALLATION / EARTHING



- 3.11 **Regulations:** The electrical installation must be carried out in accordance with the current local regulations by a qualified person.
- 3.12 **Safety:** In the interests of electrical safety a 30 mA residual current device (**R.C.D. not supplied**) should be installed in the supply circuit. This may be part of a consumer unit or a separate unit.
- 3.13 Before starting work on the electrical supply ensure power supply is isolated.
- 3.14 **DO NOT** allow the supply cord to contact hot surfaces, including the motor shell, pump body or pipework. The cord should be safely routed and secured by cable clips.
- 3.15 **Earthing:** This appliance must be earthed via the supply cord, which must be correctly connected to the earth point located in the terminal box.
- 3.16 **Connections:** The pump must be permanently connected to the fixed wiring of the mains supply using the factory fitted supply cord, via a dedicated double pole switched fused spur off the ring main.
- 3.17 **Wiring of connection unit:**



WARNING: This appliance must be earthed.

The wires in the mains lead are coloured in accordance with the following code:

Green and Yellow: Earth Blue: Neutral Brown: Live

As the colours of the wires in the mains lead of this appliance may not correspond with the coloured markings identifying the terminals in your connection unit proceed as follows:

Green and yellow coloured wire must be connected to the terminal in the connection unit marked with the letter E or by the earth symbol: \oplus or coloured green or green and yellow.

Blue coloured wire must be connected to the terminal marked with the letter N or coloured black.

Brown coloured wire must be connected to the terminal marked with the letter L or coloured red.

3.18 Wiring diagram:

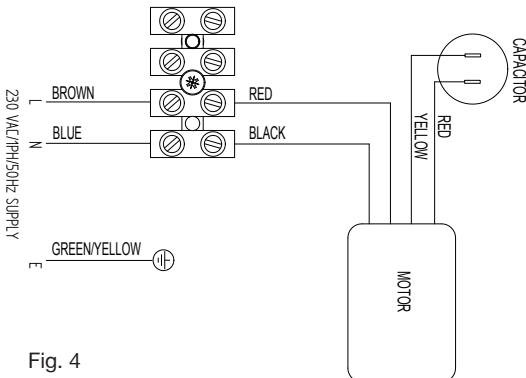

Fig. 4

3.19 **Fuse:** All models should use 13 Amp fuse.

3.20 **Supply cord replacement:**



The internal wiring within the terminal box is routed and secured to ensure compliance with the electrical standard EN 60335-1. It is essential that prior to any disturbance of this internal wiring, all cable routing and securing details are carefully noted to ensure re-assembly to the same factory pattern is always maintained.

3.21 If the supply cord is to be changed or damaged, it must be replaced by a special cord available from Stuart Turner or one of its approved repairers.

3.22 **Cable Gland Fitting Instructions:**

To enable correct assembly of the cable gland the 'O'-ring (Fig. 5 item 1) must be placed over the cable before the clamping insert (Fig. 5 item 2) can be tightened.

Note: Cable diameter range:- 9.2 mm to 11.9 mm.

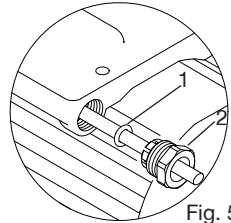

Fig. 5

3.23 **Supply Cord Extension:**

The pumps are fitted with a supply cord to the following specification:-

All models HO7RN-F3 G 1.5 mm² - 10 Amp rated cable.
If the supply cord is to be extended, a cord of the same specification should be used. Any connections or junction boxes used should be specifically suited for the application and installed in accordance with the manufacturers instructions.

4 PLUMBING

- 4.11 **Pipework:** For optimum performance pipework use 28 mm dia., 22 mm can be used but will result in reduced pump performance.
- 4.12 **Isolating valves:** Separate isolating valves (non restrictive) must be fitted to allow easy pump service.
- 4.13 This pump has a self priming ability once filled with water. It can therefore be used to draw water from a storage tank either above or below the pump position.

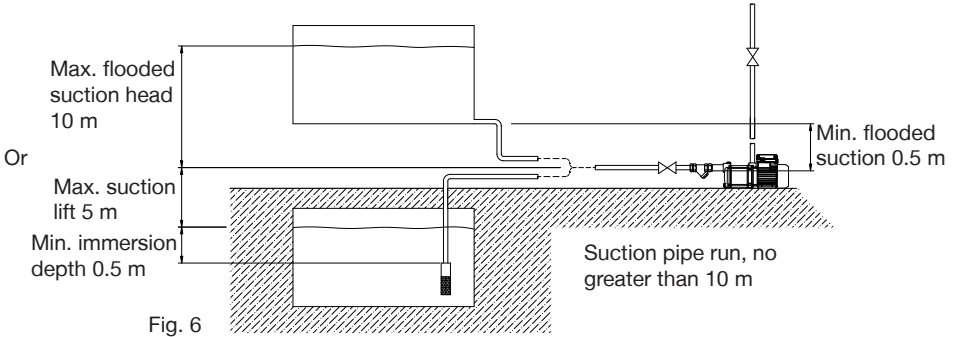

Fig. 6

We recommend the use of a footvalve and strainer when a suction lift is required, to reduce priming time.



- 4.14 **System flushing:** The pipework system should be flushed out prior to the pump being connected to ensure any contaminants/chemical residues and foreign bodies are removed from elsewhere in the system.

4.15 Priming:



Never operate pump with inlet and/or outlet isolating valves in the closed position. Damage will occur!

The pump must be primed (filled with water) before starting.

- 4.16 Turn on the isolating valves.
- Loosen vent plug and allow an even flow of water this may take a few seconds.
 - Re-seal vent plug, nipping tight.
The pump is now ready to start.

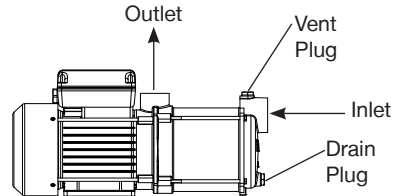

Fig. 7

- Should the pump not build up pressure after running for 2-3 minutes switch off and repeat priming process.

4.17 Maintenance:

This product is maintenance free for its life, however it is a mechanical product and will eventually show signs of wear. Spare parts are available, for more information phone the Stuart Turner PumpAssist team on +44 (0) 800 31 969 80.

5 TECHNICAL SPECIFICATION

Pump Model		CH4-30 50 Hz 46553	CH4-40 50 Hz 46554	CH4-50 50 Hz 46555	CH4-60 50 Hz 46556
General	Guarantee	2 years			
	WRAS approval	1601035			
Features	Pump type	Centrifugal			
	Mechanical seal	EPDM / Carbon / Ceramic			
Materials	Pump body	Brass / stainless steel			
	Impeller	Stainless steel			
Performance	Maximum head (closed valve)	25 metres	36 metres	50 metres	62 metres
	Performance @ 50 l/min	22 metres	34 metres	46 metres	56 metres
	Performance @ 100 l/min	13 metres	22 metres	34 metres	44 metres
	Maximum flow	140 l/min	160 l/min		
	Minimum static inlet pressure	0.05 bar (0.5 metres)			
	Maximum static inlet pressure	1.0 bar (10 metres)			
	Maximum working pressure*	600 kPa (6 bar)		900 kPa (9 bar)	
	Max. ambient air temperature (Continuous)	40 °C			
	Max. ambient air temperature (Intermittent)	50 °C			
	Min / Max water temperature**	Min 4 °C / Max 65 °C			
	Maximum Suction Lift***	5 metres			
	Connections	Pump connections	G 1½ female (inlet), G1 female (outlet)		
Motor	Type	Induction, auto-reset thermal trip			
	Duty rating	Continuous (S1)			
Electrical	Power supply / phase / frequency	230 V a.c. / 1 / 50 Hz			
	Current (full load)	3.8 Amps	5.3 Amps	7.4 Amps	8.8 Amps
	Power consumption	850 Watts	1182 Watts	1648 Watts	1969 Watts
	Fuse rating	13 Amps			
	Power cable (pre-wired)	0.75 metres			
Physical	Enclosure protection	IPX5			
	Length	360 mm	384 mm	431 mm	456 mm
	Width	155 mm		187 mm	
	Height (excluding hoses)	190 mm		210 mm	
	Weight (including fittings)	11.1 Kg	11.6 Kg	16.8 Kg	19.3 Kg

Stuart Turner reserve the right to amend the specification in line with its policy of continuous development of its products.

*Note: The maximum pressure that can be applied to the pump under any installation conditions.

**Note: A stored water temperature of 60°C is considered sufficient to meet all normal requirements and will minimise deposition of scale in hard water areas.

*** With footvalve fitted.

Although these pumps are self priming we recommend a footvalve/strainer is used if a suction lift is required.

5.11 **Noise:** The equivalent continuous A-weighted sound pressure level at a distance of 1 metre from the pump does not exceed 70 dB(A).

6 TROUBLE SHOOTING GUIDE

Symptoms	Probable Cause	Recommended Action
Pump will not start.	Electrical supply. Pump Jammed. Internal motor thermotrip activated.	Check power supply. Check fuse (see fuse section). Check circuit breaker is set. Check wiring connections. If motor 'Buzzes' switch off power and contact Stuart Turner. Wait for thermotrip to auto-reset and check that duty point and run time is within specification (see technical specification).
Reduced/intermittent flow.	Incorrect pipe sizes.	Check for correct pipe sizing, see Page 8 - Section 4.11.

- 6.11 **Environment protection:** Your appliance contains valuable materials which can be recovered or recycled.
At the end of the products' useful life, please leave it at an appropriate local civic waste collection point.

7 YOUR 2 YEAR GUARANTEE

Congratulations on purchasing a Stuart Turner pump.

We are confident this pump will provide many years of trouble free service as all our products are manufactured to the very highest standard.

All Stuart Pumps are guaranteed to be free from defects in materials or workmanship for 2 years from the date of purchase.

Within the guarantee period we will repair, free of charge, any defects in the pump resulting from faults in material or workmanship, repairing or exchanging the whole unit as we may reasonably decide.

Not covered by this guarantee: Damage arising from incorrect installation, improper use, unauthorised repair, normal wear and tear and defects which have a negligible effect on the value or operation of the pump.

Reasonable evidence must be supplied that the product has been purchased within the guarantee term prior to the date of claim (such as proof of purchase or the pump serial number).

This guarantee is in addition to your statutory rights as a consumer. If you are in any doubt as to these rights, please contact your local Trading Standards Department.

In the event of a claim please telephone **'PumpAssist'** or return the pump and flexible hoses with the accessories removed e.g pipes etc. If you have any doubt about removing a pump, please consult a professional.

+44 (0) 800 31 969 80

Proof of purchase should accompany the returned unit to avoid delay in investigation and dealing with your claim.

You should obtain appropriate insurance cover for any loss or damage which is not covered by Stuart Turner Ltd in this provision.

Please record here for your records.

TYPE NO.	SERIAL NO.	DATE PURCHASED



DECLARATION OF CONFORMITY

2006/42/EC

BS EN ISO 12100-1, BS EN ISO 12100-2, BS EN 809

2014/35/EU

BS EN 60335-1, BS EN 60335-2-41

2014/30/EU

BS EN 55014-1, BS EN 55014-2, BS EN 55022, BS EN 61000-3-2, BS EN 61000-3-3,
BS EN 61000-4-2, BS EN 61000-4-3, BS EN 61000-4-4, BS EN 61000-4-5, BS EN 61000-4-6,
BS EN 61000-4-11

1999/519/EC

BS EN 62233

2011/65/EU

IT IS HEREBY CERTIFIED THAT THE STUART ELECTRIC MOTOR DRIVEN PUMP AS SERIAL NUMBER BELOW, COMPLIES WITH THE ESSENTIAL REQUIREMENTS OF THE ABOVE E.E.C. DIRECTIVES.



RESPONSIBLE PERSON
AND MANUFACTURER

STUART TURNER LIMITED
HENLEY-ON-THAMES, OXFORDSHIRE
RG9 2AD ENGLAND.

Signed.......... Business Development Director

Stuart Turner are an approved company to BS EN ISO 9001:2008



Stuart Turner Ltd, Henley-on-Thames, Oxfordshire RG9 2AD ENGLAND

Tel: +44 (0) 1491 572655, Fax: +44 (0) 1491 573704

info@stpumps.co.uk www.stuart-turner.co.uk