

stuart

CH 4 Centrifugal Horizontal Multistage Pumps

The CH 4 range of centrifugal multistage pumps are built to provide a high quality and reliable solution for applications that require high flow rates of up to 160 l/min and heads up to 62 metres.

The range includes 4 base pumps suitable for independent switching.

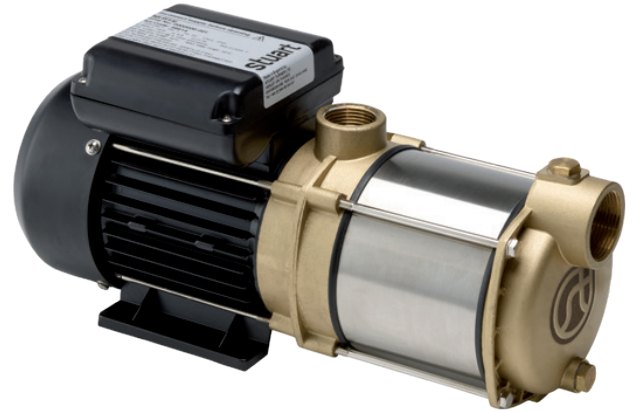

Features

- Self priming up to 5 m
- Quiet operation
- Easy to install
- Stainless steel impeller and pump shaft
- Brass and stainless steel pump body
- Continuously rated induction motor

Application

- The CH 4 range of pumps are the ideal base unit for pressure boosting sets or for applications where long pipe runs or high heads may be involved
- The range is suitable for commercial or domestic use, pumping hot or cold water

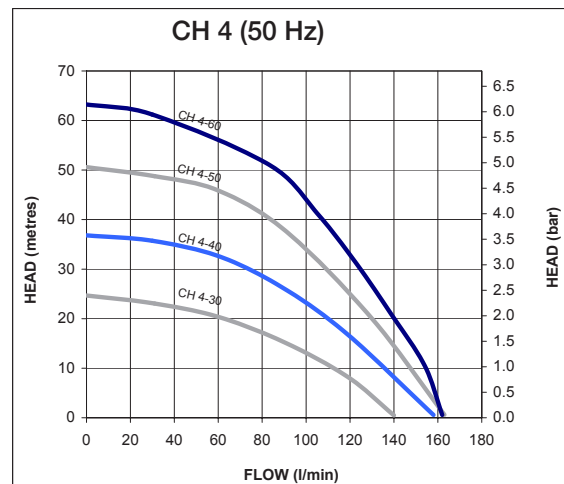

For further advice on selecting the correct pump call
or e-mail info@stpumps.co.uk

pumpassist
HELPLINE +44 (0) 800 31 969 80

Pump Model		CH 4-30 50 Hz 46553	CH 4-40 50 Hz 46554	CH 4-50 50 Hz 46555	CH 4-60 50 Hz 46556
General	Guarantee	2 years			
	WRAS approval	1601035			
Features	Pump type	Centrifugal			
	Mechanical seal	EPDM / Carbon / Ceramic			
Materials	Pump body	Brass / stainless steel			
	Impeller	Stainless steel			
Performance	Maximum head (closed valve)	25 metres	36 metres	50 metres	62 metres
	Performance @ 50 l/min	22 metres	34 metres	46 metres	56 metres
	Performance @ 100 l/min	13 metres	22 metres	34 metres	44 metres
	Maximum flow	140 l/min	160 l/min		
	Minimum static inlet pressure	0.05 bar (0.5 metres)			
	Maximum static inlet pressure	1.0 bar (10 metres)			
	Maximum working pressure*	600 kPa (6 bar)		900 kPa (9 bar)	
	Max. ambient air temperature (Continuous)	40 °C			
	Max. ambient air temperature (Intermittent)	50 °C			
	Min / Max water temperature**	Min 4 °C / Max 65 °C			
Maximum Suction Lift***	5 metres				
Connections	Pump connections	G 1¼ female (inlet), G 1 female (outlet)			
Motor	Type	Induction, auto-reset thermal trip			
	Duty rating	Continuous (S1)			
Electrical	Power supply / phase / frequency	230 V a.c. / 1 / 50 Hz			
	Current (full load)	3.8 Amps	5.3 Amps	7.4 Amps	8.8 Amps
	Power consumption	850 Watts	1182 Watts	1648 Watts	1969 Watts
	Fuse rating	13 Amps			
	Power cable (pre-wired)	0.75 metres			
Physical	Enclosure protection	IPX5			
	Length	360 mm	384 mm	431 mm	456 mm
	Width	155 mm		187 mm	
	Height (excluding hoses)	190 mm		210 mm	
	Weight (including fittings)	11.1 Kg	11.6 Kg	16.8 Kg	19.3 Kg

* The maximum pressure that can be applied to the pump under any installation conditions.

** A stored water temperature of 60 °C is considered sufficient to meet all normal requirements and will minimise deposition of scale in hard water areas.

*** With footvalve fitted.

Although these pumps are self priming we recommend a footvalve/strainer is used if a suction lift is required.

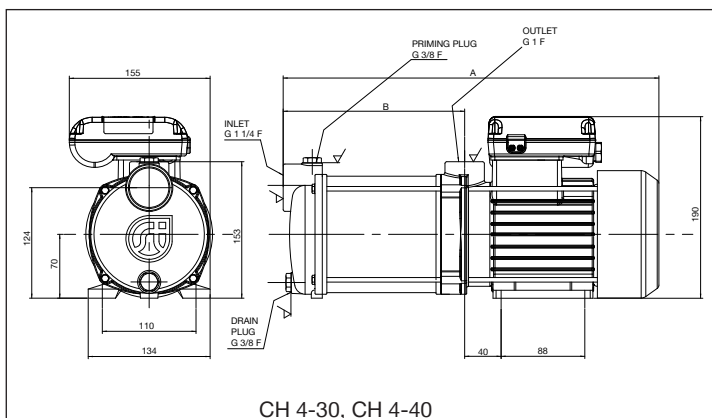

CH 4-30, CH 4-40

Pump Description	Dim. 'A'	Dim. 'B'
CH 4-30	360 mm	146 mm
CH 4-40	384 mm	170 mm

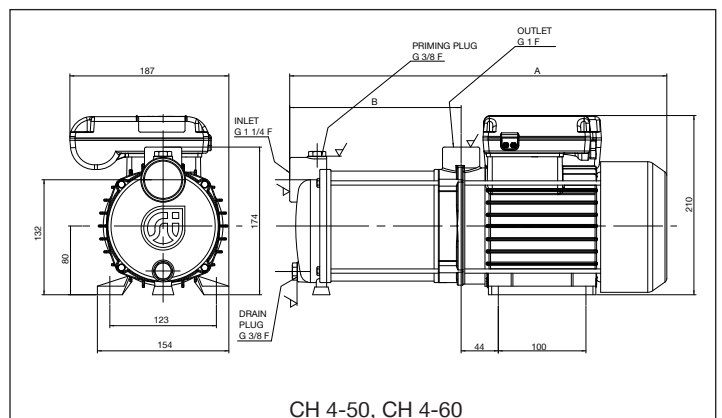

CH 4-50, CH 4-60

Pump Description	Dim. 'A'	Dim. 'B'
CH 4-50	431 mm	198 mm
CH 4-60	456 mm	222 mm

Stuart Turner Limited reserves the right to amend specifications without notice.