

**stuart**

**CH Boostamatic Pressure Switch Pumps CH 4-50 B, CH 4-60 B**

Note: The pressure vessel can be re-positioned if required to suit specific installations. However care must be taken when re-positioning to ensure no strain is placed upon the pressure switch or flow switch cables (not shown).

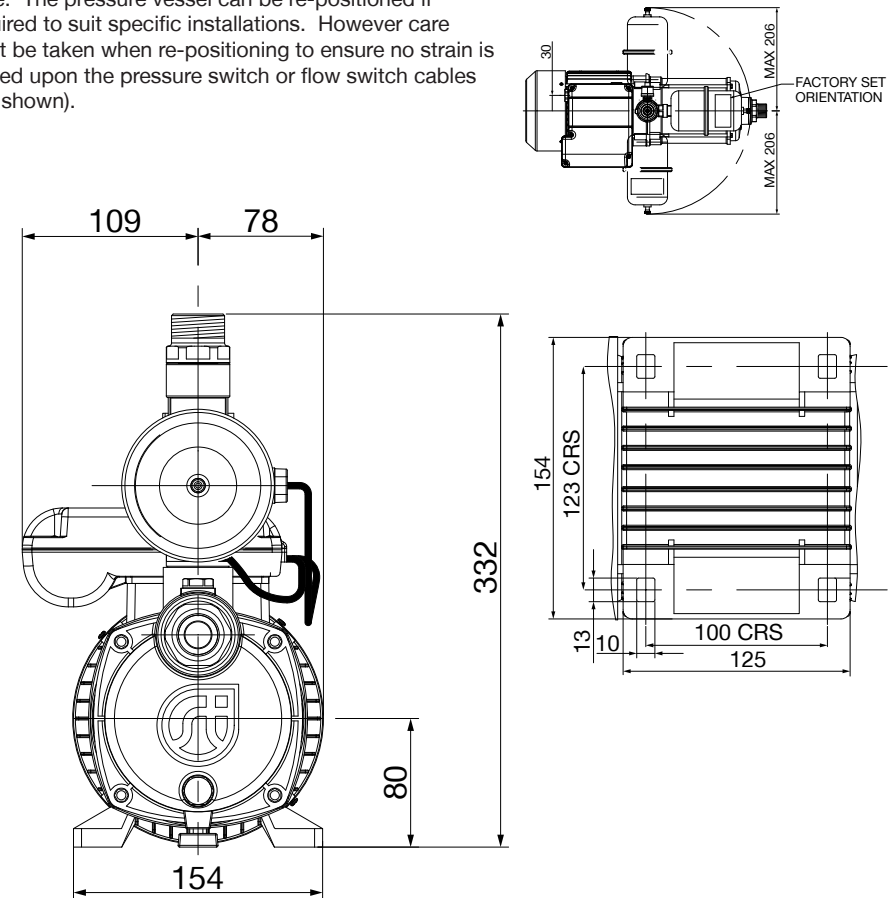
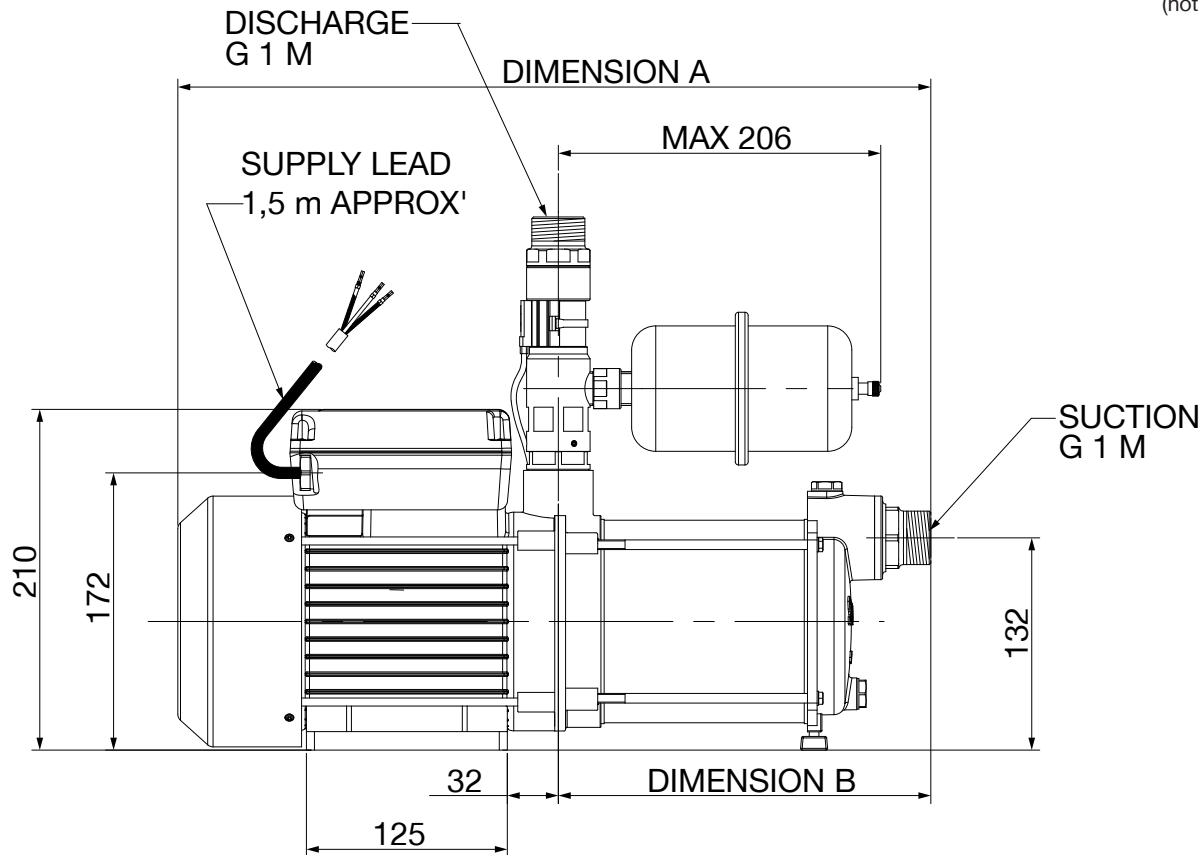

Note:  
Suction - G 1 1/4 F  
Discharge - G 1 F

Pump Description	Dim. 'A'	Dim. 'B'
CH 4-50 B	469 mm	236 mm
CH 4-60 B	494 mm	260 mm

Dimensions in millimetres

For further advice on selecting the correct pump call  
or e-mail [info@stpumps.co.uk](mailto:info@stpumps.co.uk)

Issue 0917/4

Stuart Turner Ltd own the copyright within this document. The document may be printed for personal use only. The document must not be altered, reproduced or utilised in any way without written permission from Stuart Turner Ltd, Henley-on-Thames, Oxfordshire, RG9 2AD, England.

Stuart Turner Ltd reserve the right to amend the document or product specifications in line with it's policy of continuous development.

**pumpassist**  
HELPLINE +44 (0) 800 31 969 80