

# mainsboost

## Mainsboost Flomate MBF 100 / MBF 200 / MBF 300

Mainsboost Flomate is suitable for larger properties with multiple bathrooms and outlets.

Designed to sit within a typical kitchen 600 mm larder style cupboard it will deliver up to 30 litres/minute flow at 3.2 bar pressure, dependant on the chosen pressure vessel variant, to multiple outlets within the property, up to the preset cut-in limit at which time the system will deliver 12 litres/minute until demand ends and the pressure vessel recharges.



### Features

- Boost flow rates up to 18 l/min (MBF 100), 24 l/min (MBF 200), or 30 l/min (MBF 300)
- Boost pressure up to 3.2 bar
- Continuously rated
- Pre-wired with 1.5 metre power cable
- 3 year guarantee (subject to conditions)
- Automatic switching
- Easy installation
- Includes comprehensive 15 mm Upstream Line-in Kit (ULK) as standard

### Application

- Suitable for higher occupancy properties with two bathrooms or more, MBF 100/200/300 requires no on-site commissioning and fits neatly within a standard 600 mm kitchen larder unit.

Description	Typical Run Time in Minutes				
	12 l/min	16 l/min	18 l/min	24 l/min	30 l/min
MBF 100-1-15	Continuous	16	8	-	-
MBF 200-1-15	Continuous	24	18	8	-
MBF 300-1-15	Continuous	40	24	16	8

# mainsboost

Pump Model		MBF 100-1-15 46635	MBF 200-1-15 46636	MBF 300-1-15 46637
General	Guarantee	3 years		
	WRAS approval	1611375		
Features	Pump type	Peripheral		
	Mechanical seal	EPDM / PTFE / Al. Oxide		
	Flexible hoses	2	2	2
	Diaphragm tank size	100 litre	200 litre	300 litre
	Diaphragm tank water capacity	50 litre	100 litre	150 litre
	Dry run protection	✓	✓	✓
Materials	Pump body	Brass		
	Impeller	Brass		
Performance	Maximum head (closed valve)	3.2 bar		
	Maximum flow	18 l/min	24 l/min	30 l/min
	Maximum working pressure*	450 kPa (4.5 bar)		
	Maximum ambient air temperature	40 °C		
	Min / Max water temperature	Min 4 °C / Max 35 °C		
	Flow switch sensitivity (approx)	0.6 l/min		
Connections	Pump connections	G ¾ male		
Flexible hoses	Connections	G ¾ female x 15 mm push-in x 200 mm long		
Motor	Type	Induction, auto-reset thermal trip		
	Duty rating	Continuous		
Electrical	Power supply / phase / frequency	230 V a.c. / 1 / 50 Hz		
	Current (full load)	1.7 Amps		
	Power consumption	365 Watts		
	Fuse rating	5 Amps		
	Power cable (pre-wired)	1.5 metres		
Physical	Enclosure protection	IPX4		
	Length	461 mm	556 mm	
	Width	430 mm	532 mm	
	Height (excluding hoses)	1134 mm	1390 mm	1847 mm
	Dry weight (including fittings)	24.5 Kg	40 Kg	54 Kg
	Filled weight (maximum)	72.5 Kg	143 Kg	206 Kg

\* The maximum pressure that can be applied to the pump under any installation conditions.

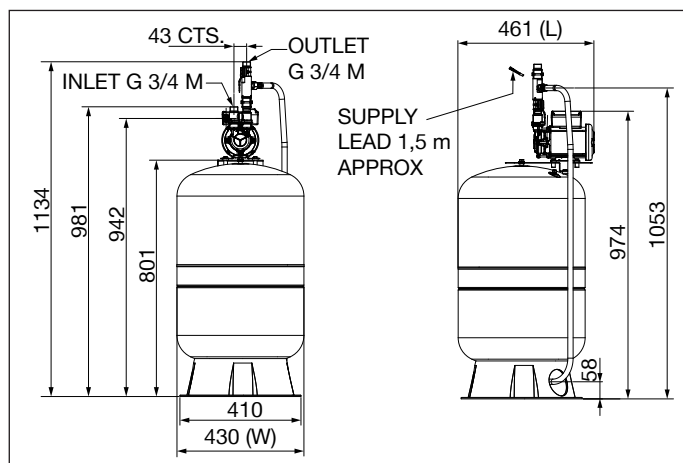

**MBF 100**

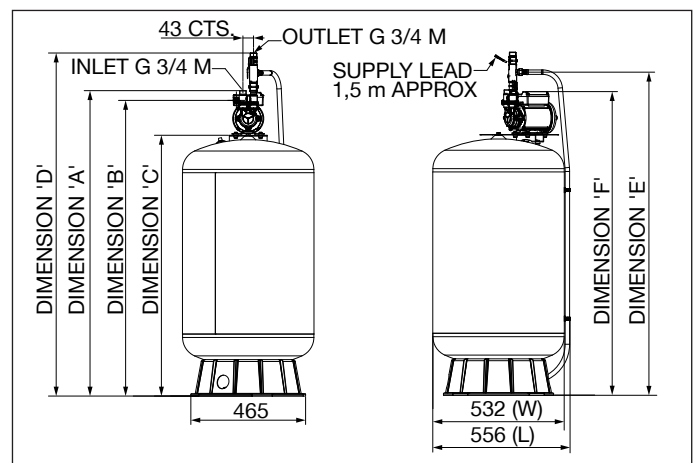

**MBF 200 / MBF 300**

Pump Description	Dim. 'A'	Dim. 'B'	Dim. 'C'	Dim. 'D'	Dim. 'E'	Dim. 'F'
MBF 200-1-15	1237	1198	1057	1390	1310	1230
MBF 300-1-15	1694	1655	1513	1847	1766	1687

Stuart Turner Limited reserves the right to amend specifications without notice.