

stuart

Jet Pressure Sets

Ideal for the high pressure delivery of clean non-potable water from a water tank / cistern in either a positive or negative head application. Jet Pressure Sets include a 24 litre diaphragm tank providing a buffer of 12 litres of pressurised stored water and are supplied with a power lead fitted with a 13 amp fused plug.

The range is suitable for general purpose applications, pumping cold water.



Features

- 1.5 m lead and 13 Amp plug fitted
- Fully automatic control
- No on-site setting/commissioning
- Built in 'no water' cut out
- No pulsing in operation
- Easy installation
- Reliable
- Quiet operation

Application

- Designed for pumping clean non-potable water. The portable Jet PS pump is ideal for many household and light industrial uses.
- Water pressurisation and lawn sprinkler boosting are just two of its many applications.

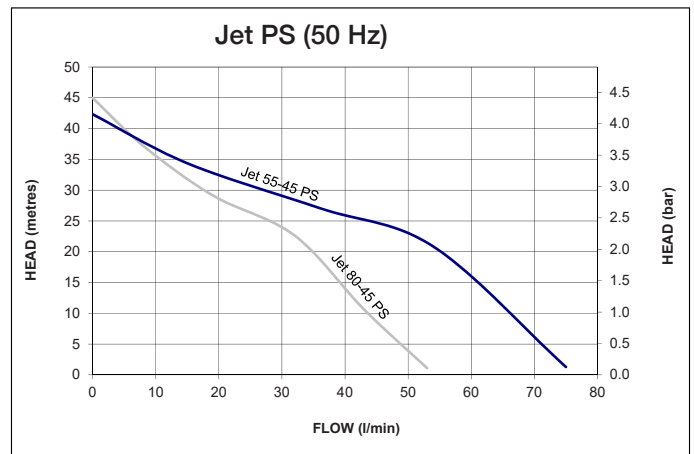

Pump Model		Jet 55-45 PS 50 Hz 46617	Jet 80-45 PS 50 Hz 46618
General	Guarantee	1 year	
Features	Pump type	Centrifugal	
	Mechanical seal	EPDM / Carbon / Ceramic	
	Fully automatic control	✓	✓
	24 litre diaphragm tank	✓	✓
	Built in no water cut out	✓	✓
	Positive and negative head application	✓	✓
	Quiet operation	✓	✓
Materials	Pump body	Stainless steel	
	Impeller	Plastic	
Performance	Maximum head (closed valve)	4.5 bar	4.5 bar
	Performance @ 10 l/min	3.5 bar	3.6 bar
	Performance @ 40 l/min	1.6 bar	2.5 bar
	Maximum flow	55 l/min	80 l/min
	Minimum static inlet pressure	0.1 bar (1 metre)	
	Maximum static inlet pressure	0.5 bar (5 metres)	
	Maximum static outlet pressure	1.3 bar (13 metres)	
	Maximum working pressure*	500 kPa (5 bar)	
	Maximum ambient air temperature	40 °C	
	Min / Max water temperature	Min 4 °C / Max 35 °C	
	Maximum suction lift	5 metres	
	Cut out flow	1 l/min (approx)	
	Cut in pressure	180 kPa (1.8 bar)	
Pressure vessel air pre-charge	2.0 bar (29 psi)		
Connections	Pump connections	G 1 female	
Motor	Type	Induction, auto-reset thermal trip	
	Duty rating	Continuous (S1)	
Electrical	Power supply / phase / frequency	230 V a.c. / 1 / 50 Hz	
	Current (full load)	2.9 Amps	5.2 Amps
	Power consumption	640 Watts	925 Watts
	Fuse rating	13 Amps	
	Power cable (pre-wired)	1.5 metres	
Physical	Enclosure protection	IPX4	
	Length	521 mm	
	Width	280 mm	
	Height (excluding hoses)	700 mm	
	Weight (including fittings)	13.2 Kg	15.7 Kg

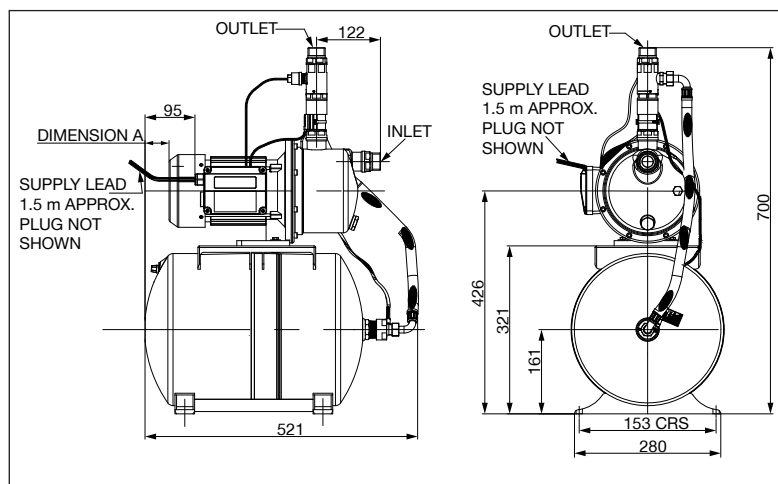

* The maximum pressure that can be applied to the pump under any installation conditions.

Pump Description	Dim. 'A'
Jet 55-45 PS	71 mm
Jet 80-45 PS	46 mm

Stuart Turner Limited reserves the right to amend specifications without notice.