

# Clarke®



## ENGINE DRIVEN 3" FULL TRASH PUMP

MODEL NO: PF75A

PART NO: 7230166

### OPERATION & MAINTENANCE INSTRUCTIONS



ORIGINAL INSTRUCTIONS

LS0120 ISS 1

---

## INTRODUCTION

---

Thank you for choosing this CLARKE Pump.

The function of this pump is to move clean /dirty water (maximum solid width of 28 mm).

DO NOT use it to pump:

- Sewage
- Dangerous liquids.
- Salt water

Before you use this pump, read the manual fully.

---

## GUARANTEE

---

This pump is guaranteed against faulty manufacture for a period of 12 months from the date of purchase.

Please keep your receipt which will be required as proof of purchase.

This guarantee is invalid if the pump has been abused, tampered with, or not used for its primary function.

Faulty goods must be returned to their place of purchase, no pump can be returned to us without prior permission.

This guarantee does not effect your statutory rights.

---

## INVENTORY

---

You should find the items in the list below in the carton

|  |                          |
|--|--------------------------|
| 1 x Petrol Powered 3" Water Pump               | 1 x Tommy Bar            |
| 1 x Spark Plug Box Wrench                      | 2 x Rubber Sealing Rings |
| 2 x 3" Hose adaptors                           | 2 x 3" Locking Rings     |
| 1 x Metal Inlet Strainer with 3" Hose adaptors | 3 x Hose Clips           |

Speak to your CLARKE dealer If items are missing or damaged.

---

## GENERAL SAFETY RULES

---



**WARNING: WHEN USING PUMPS, ALWAYS FOLLOW BASIC SAFETY PRECAUTIONS TO REDUCE THE RISK OF FIRE, ELECTRIC SHOCK AND PERSONAL INJURY. READ ALL INSTRUCTIONS BEFORE YOU OPERATE THIS PUMP AND SAVE THEM FOR FUTURE REFERENCE.**

---

1. ALWAYS obey all safety precautions for the handling of fuel.
2. ALWAYS make sure that you are familiar with this pump, and follow all instructions in this manual.
3. ALWAYS make sure that the pump is positioned correctly to prevent it from moving during operation.
4. Keep the area adjacent to the pump clear.
5. ALWAYS connect the strainer to the suction hose to stop stones and other solids from being pulled into the pump. These can cause damage to the pump.
6. ALWAYS keep the pump dry and clear of discharge hose.
7. Only use parts supplied by the manufacturer. Using non-standard parts can be dangerous.
8. ALWAYS use at least 300mm of flexible hose to make plumbing connections to the pump. Rigid piping can put stress on the pump, causing damage. If you use rigid piping, it must be supported to eliminate stress on the connections.
9. DO NOT refuel the engine while it is operating and allow the engine cool sufficiently before refuelling.
10. DO NOT use to pump petrol (or other flammable liquids), or corrosive chemicals. The function of this pump is to pump WATER ONLY.
11. DO NOT operate this pump in an explosive atmosphere, near combustible materials, or where there is insufficient ventilation.
12. DO NOT let children use this pump.
13. DO NOT run the pump dry. Always fill the pump with water before starting.
14. DO NOT direct the discharge flow towards another person.
15. DO NOT over-tighten drain or filler plugs. Excessive force can damage the threads or the pump body.
16. DO NOT direct the water discharge towards electrical wiring or equipment.

## GENERAL SAFETY IN THE WORKPLACE

1. ALWAYS keep work area clean & tidy. Cluttered work areas invite accidents.
2. NEVER over-reach. Keep proper footing and balance at all times.
3. ALWAYS make sure that the workplace is well lit. Make sure that that lighting is placed so that you will not be working in your own shadow.
4. Dress correctly. Loose clothing or jewellery can get caught in moving parts. Non-slip footwear is recommended. Wear protective hair covering to contain long hair.
5. ALWAYS wear safety glasses. (Everyday glasses are not safety glasses).

## CARE OF PUMPS

1. The CLARKE service department must replace damaged components.
2. ALWAYS examine the pump for damage that can effect the operation of the pump. Repair any damaged parts.
3. Have your pump repaired by a qualified person. Repairs must only be carried out by qualified persons using original spare parts.

**Keep the instructions for future reference.**

## SAFETY SYMBOLS

The meanings of the markings and symbols on the pump are shown below.



Read this manual before use and keep it for future reference

# ASSEMBLY

## INSTALL THE SUCTION HOSE

1. Put the rubber washer into the adaptor.
  - Make sure that it is seated correctly.
2. Screw the adaptor onto the pump securely.
3. Slide the hose on to the adaptor and lock in position with the hose clip supplied.
  - 3" Reinforced Hose is available from your CLARKE Stockist (Part number - 7955030)
4. Install the strainer on to the other end of the hose following the picture on the right.

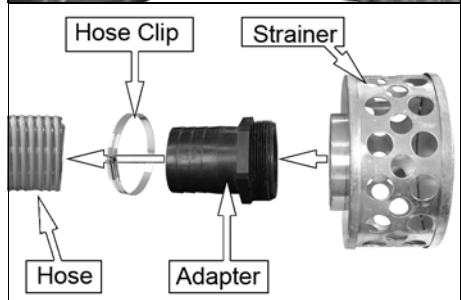
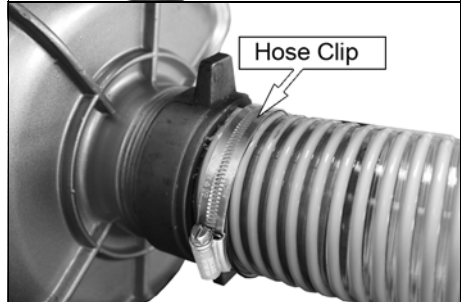
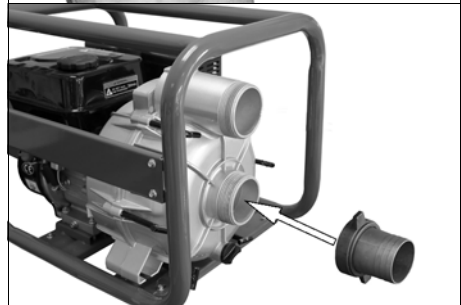

## INSTALL THE DISCHARGE HOSE

1. Put the rubber washer into the adaptor.
  - Make sure that it is seated correctly.
2. Screw the adaptor onto the pump securely.
3. Slide the hose on to the adaptor and lock in position with the hose clip supplied.
  - 3" Reinforced Hose is available from your CLARKE Stockist (Part number - 7955030)

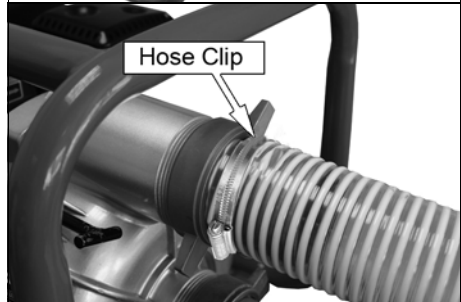
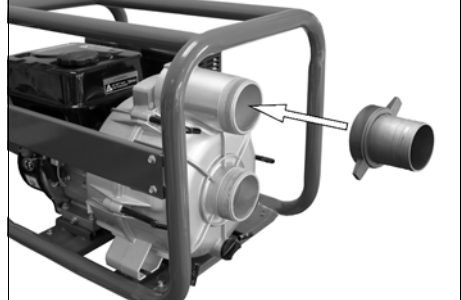
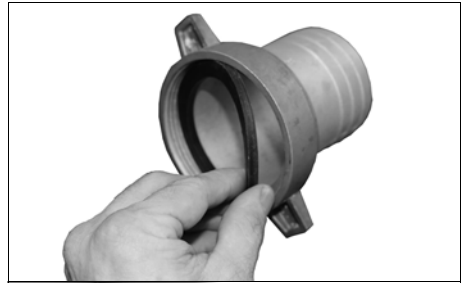

---

## BEFORE USE

---

### PUMP PLACEMENT

For best pump performance, place the pump near the water level, and use hoses that are no longer than necessary. That will enable the pump to produce the greatest output with the least self-priming time.

As head (pumping height) increases, pump output decreases. The length, type, and size of the suction and discharge hoses can also significantly affect pump output.

Discharge head capability is always greater than suction head capability, so it is important for suction head to be the shorter part of total head.

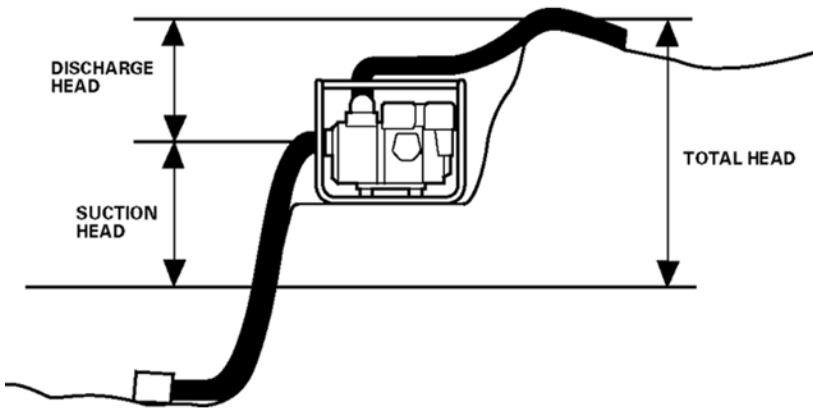

## CHECK THE ENGINE OIL LEVEL



**WARNING: TO DO THIS CHECK, PUT THE PUMP ON LEVEL GROUND WITH THE ENGINE SWITCHED OFF.**

**WARNING: TAKE CARE NOT TO TOUCH ANY HOT PARTS OF THE PUMP WHEN CHECKING THE OIL LEVEL.**

1. Turn the oil filler cap anti-clockwise and remove from the oil fill tube.
2. Clean the dipstick with a clean cloth.
3. Put the dipstick into the oil fill tube and then remove it again. Do not screw in the oil filler cap/dipstick when doing this.
4. If the oil level is at or below the 'L' mark on the dipstick, add oil to the crankcase.
  - Fill until the oil touches the threads in the oil fill tube.
  - Oil capacity (See page 20).
  - We recommend you use SAE15W40 oil in this pump. available from your CLARKE dealer.
5. Replace the oil filler cap.

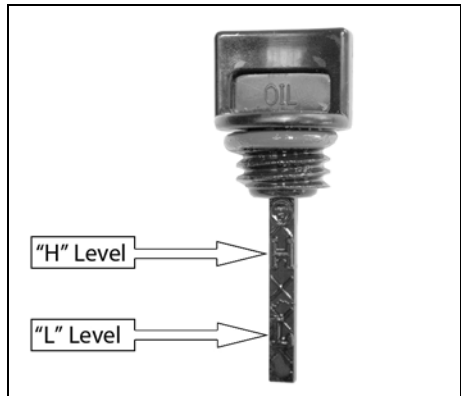
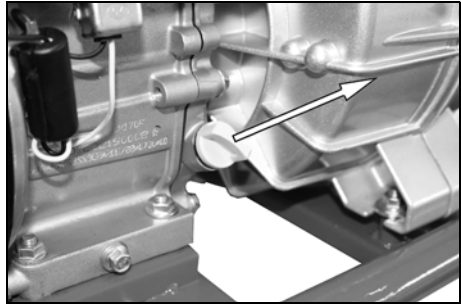



## ADD FUEL



**WARNING: REFUEL IN A VENTILATED AREA, AWAY FROM SOURCES OF IGNITION.**

**WARNING: IF THE ENGINE IS HOT, LET IT COOL BEFORE REFUELING.**

**WARNING: KEEP FUEL OUT OF THE REACH OF CHILDREN.**

### RECOMMENDED FUEL

**Only use unleaded petrol.**

1. Remove the fuel tank cap.
  - In the fuel tank is a fuel filter which collects contaminants as you refuel.
2. Slowly add fuel to the fuel tank.
  - Make sure that the fuel level is not above the maximum fuel level mark in the fuel filter.
3. Replace the fuel tank cap.

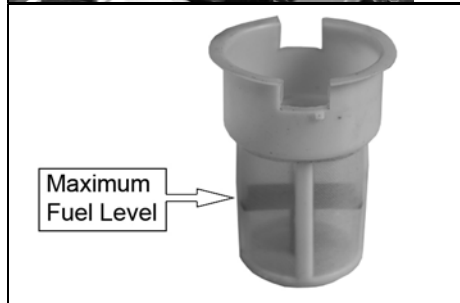

---

# OPERATION

---



**WARNING: WHEN YOU OPERATE THE PUMP, THE EXHAUST MUFFLER WILL BE VERY HOT.**

**WARNING: DO NOT OPERATE THE ENGINE IN A CLOSED SPACE, MAKE SURE THAT THERE IS SUFFICIENT AIRFLOW AROUND THE PUMP.**

---

## PRIME THE PUMP

1. The pump **MUST** be primed before use.
2. Before starting the engine, remove the filler cap from the pump chamber.
3. Completely fill the pump chamber with water.
4. Reinstall the filler cap, and tighten it securely.

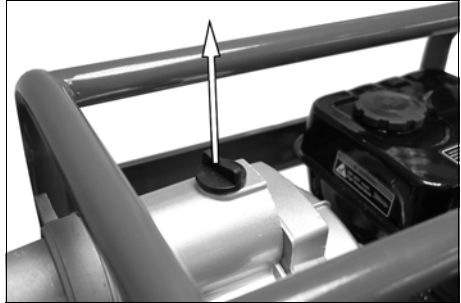

**WARNING: OPERATING THE PUMP DRY WILL DESTROY THE PUMP SEAL. IF THE PUMP HAS BEEN OPERATED DRY, STOP THE ENGINE IMMEDIATELY, AND ALLOW THE PUMP TO COOL BEFORE PRIMING**

---

## START THE ENGINE

### 1. MAKE SURE THE PUMP IS PRIMED (SEE PAGE 10)

2. Set the fuel valve to the ON position.



3. To start a cold engine, move the choke lever to the 'OFF' position.

- To restart a warm engine, leave the choke lever in the 'ON' position.



4. Move the throttle lever away from Slow about 1/3 of the way.

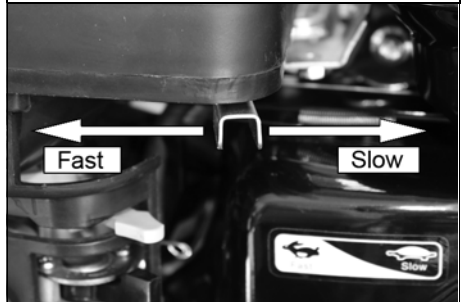

5. Set the engine switch to 'ON'.



6. Pull the starting handle lightly until you start to feel resistance. Then pull up and away suddenly to start the engine.

**NOTE:** You might need to do this more than once.

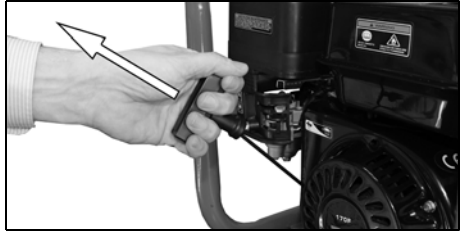

**WARNING: WHEN THE PUMP HAS STARTED, RELEASE THE STARTING HANDLE SLOWLY TO PREVENT INJURY/DAMAGE AS IT RETURNS.**

7. Once the engine has warmed up from a cold start, move the choke lever to the 'ON' position.

### **SETTING THE ENGINE SPEED**

After starting the engine, move the throttle lever to the FAST position for self-priming, and check pump output.

Pump output is controlled by adjusting engine speed.

- Moving the throttle lever in the FAST direction will increase pump output.
- Moving the throttle lever in the SLOW direction will decrease pump output.

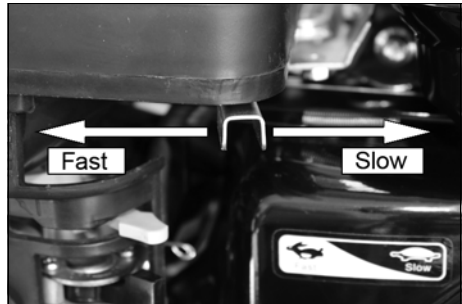

## SHUT DOWN THE PUMP

To stop the pump in an emergency, set the engine switch to 'OFF'.

1. Use the throttle lever to decrease engine speed to minimum.

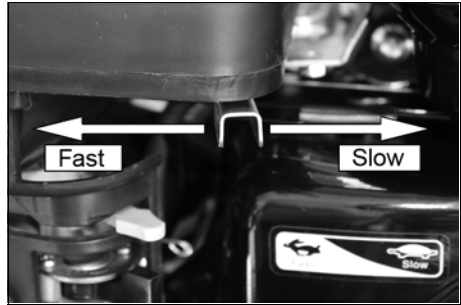

2. Set the engine switch to "OFF".



3. Turn the fuel valve to "OFF".



## AFTER USE

1. Remove the pump drain plug, and drain the pump chamber.
2. Remove the filler cap, and flush the pump chamber with clean, fresh water.
  - Allow the water to drain from the pump chamber, then
3. Reinstall the filler cap and drain plug.

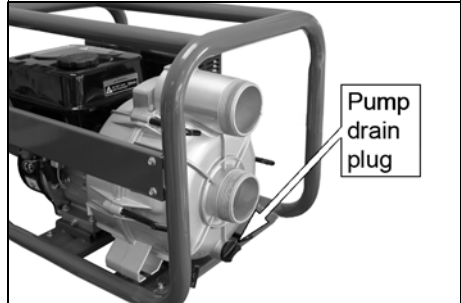

# MAINTENANCE

## CLEARING BLOCKAGES

1. Remove the hoses and adaptors from the pump.

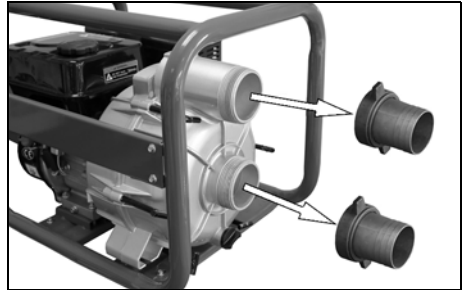

2. Remove the 6 locking rods.

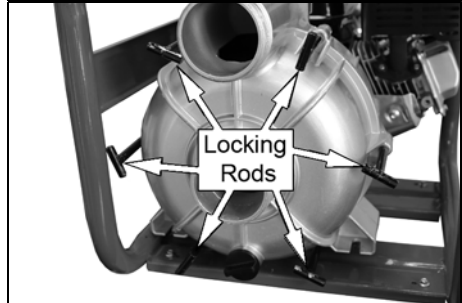

3. Remove the front cover.
4. Clear debris and clean the inner parts using clean water.
5. Replace the front cover and secure using the 6 locking rods.



## CHANGING THE ENGINE OIL



CAUTION: PROLONGED EXPOSURE TO USED ENGINE OIL IS DANGEROUS, ALWAYS WASH YOUR HANDS THOROUGHLY AFTER HANDLING USED ENGINE OIL.

Change the oil in the engine after the first 20 hours use and thereafter every 6 months or 100 running hours.

1. Unscrew and remove the oil filler cap/dipstick.
2. Put a oil collection tray below the drain plug.
3. Unscrew the drain plug and let the used engine oil drain from the crankcase into the oil collection tray.

**NOTE:** Drain the engine oil when the engine is warm, this will make sure that the oil flows out faster.

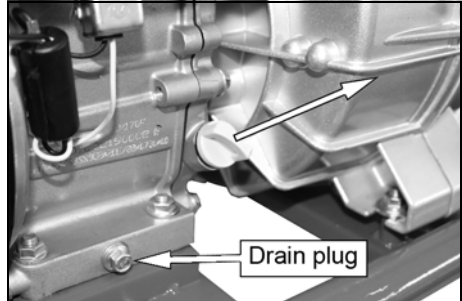

4. Replace the drain plug.
5. Fill the crankcase with engine oil.
  - Fill until the oil touches the threads in the oil fill tube.
  - Oil capacity (0.6l).
  - We recommend that you use SAE15W40 oil in this pump available from your CLARKE dealer.
6. Replace the oil filler cap/dipstick.

### ENVIRONMENTAL PROTECTION

One of the most damaging sources of pollution is oil, do not throw away or pour it down drains. Put it in a leak proof container and take it to your local waste disposal site.

## CHANGING THE SPARK PLUG

Replace the spark plug after the first month or every 50 hours of use.

1. Remove the spark plug cap from the spark plug.



2. Use the spark plug spanner supplied to remove the spark plug.
3. Remove any carbon that has collected around the electrode.

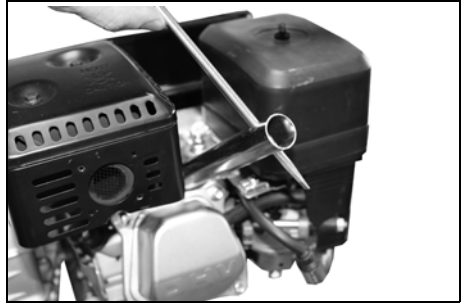

4. Check the spark plug gap (a), it should be between 0.7 and 0.8 mm, adjust if necessary.
5. Check the overall condition of the spark plug for erosion or pitting and replace if necessary.
6. Reinstall the spark plug and replace the spark plug cap.

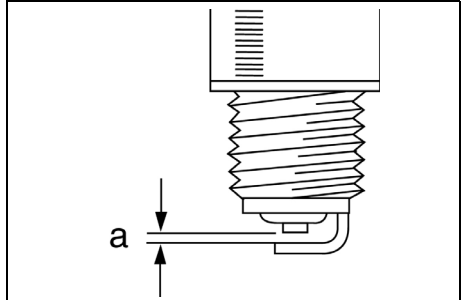



## CHANGING THE AIR FILTER

Clean the air filter after 50 hours of operation (or more often in unusually dusty conditions) as follows.

1. Unscrew the wingnut and lift off the air filter cover.

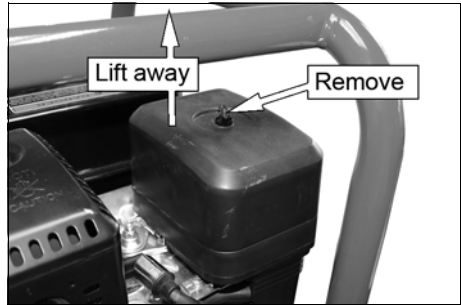

2. Remove the wingnut that holds the air filter in position.

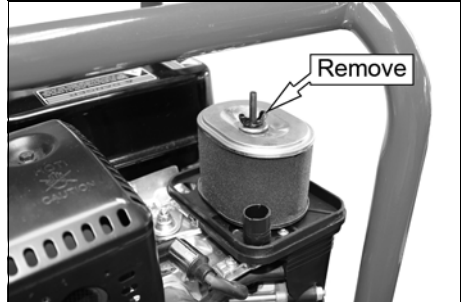

3. Remove the air filter element.

4. Clean the air filter or replace if necessary.

- If the filter is dirty, wash the filter in a solution of warm water and mild detergent and rinse thoroughly. Leave the filter to dry completely,

5. Once it is dry, Dip in clean engine oil and squeeze out excess oil.



- Do not operate the pump without the air cleaner installed as this will cause premature wear to the engine.

## STORAGE

1. Always keep the pump in a clean condition, checking regularly for loose bolts etc.

## TROUBLESHOOTING

| PROBLEM                                | CAUSE  | SOLUTION  |
|--|--|---|
| The engine does not start.             | No fuel in tank.   | Add fuel.   |
|  | Fuel valve is set to OFF   | Set the fuel valve to ON  |
|  | Engine switch is in the OFF position.  | Set engine switch to the ON position.   |
|  | Lack of spark at the spark plug.   | <p>Make sure that the spark plug cover is fitted on to the plug.</p> <p>With the engine switch in the ON position, hold the spark plug electrode against the engine and pull the starter cord. If a spark is present but engine will not start, consult your CLARKE dealer.</p> |
| The engine stops and will not restart. | No fuel in tank.   | Add fuel to the tank.   |
| The pump fails to prime.               | Priming chamber not filled correctly.  | Fill priming chamber leaving no air gap.  |
|  | Air leaking due to damaged hose, broken hose clamps, split/ill-fitting gasket. | Repair as necessary.  |
|  | Blocked inlet hose.  | Clean strainer and make sure that it is not submerged in mud or sediment. Make sure that there are no kinks in the delivery hose.   |
|  | Engine speed too low.  | Increase engine speed.  |
|  | Damaged impeller.  | Disassemble the pump and replace the impeller.  |
|  | Air leaking through damaged seal.  | Replace seal.   |

| <b>PROBLEM</b>        | <b>CAUSE</b>                        | <b>SOLUTION</b>  |
|-----------------------|-------------------------------------|--|
| Low output from pump. | The engine speed is too low.        | Increase the engine speed.                                       |
|                       | Pickup or delivery hose obstructed. | Clear obstruction and make sure that there are no kinks in hose. |
|                       | Suction lift too high.              | Set the pump nearer to the water level.                          |
|                       | Congested material inside pump.     | Disassemble the pump and clean out.                              |
|                       | Damaged impeller.                   | Disassemble the pump and replace the impeller.                   |

If you cannot correct the fault, speak to your local dealer or the CLARKE International service department.

---

## **ENVIRONMENTAL PROTECTION**

---

At the end of its working life, do not discard this pump or its components with general household waste. Packaging must be taken to a recycling centre and discarded appropriately.

One of the most dangerous sources of pollution is oil. Do not discard used oil with domestic refuse or flush down a sink or drain. Collect the oil in a leak-proof container and take it to your local waste disposal site.

## SPECIFICATION

| Item                           | Spec                                |
|--------------------------------|-------------------------------------|
| pump dimensions (L x W x H)    | 550 x 430 x 455 mm                  |
| pump Weight (kgs)              | 28.25 kg                            |
| Water classification           | Dirty / Clean (NOT SEWAGE)          |
| Max solids                     | 28 mm                               |
| Inlet/Outlet Size              | 3"                                  |
| Maximum Flow                   | 1300l/min (78m <sup>3</sup> /h) max |
| Max Head                       | 28 m                                |
| Suction Head                   | 7-8 m                               |
| Max Pressure                   | 2.8 bar                             |
| Run time @75% rated load       | 2.77 hrs                            |
| Engine type/speed              | 7HP (4 stroke) 3600 rpm             |
| Fuel tank capacity (petrol)    | 3.6 L                               |
| Lubrication oil capacity/grade | 0.6 L (SAE 15W40)                   |
| Sound Pressure Level           | 89.5 dB LpA                         |
| Sound Power Level              | 103 dB LWA                          |
| Guaranteed sound power level   | 105 dB LWA                          |
| Uncertainty Factor (K)         | 2.5 dB                              |

# EXPLODED DIAGRAMS AND PARTS LIST

A full set of parts list and diagrams are available from the CLARKE International service department.

## WATER PUMP ASSEMBLY

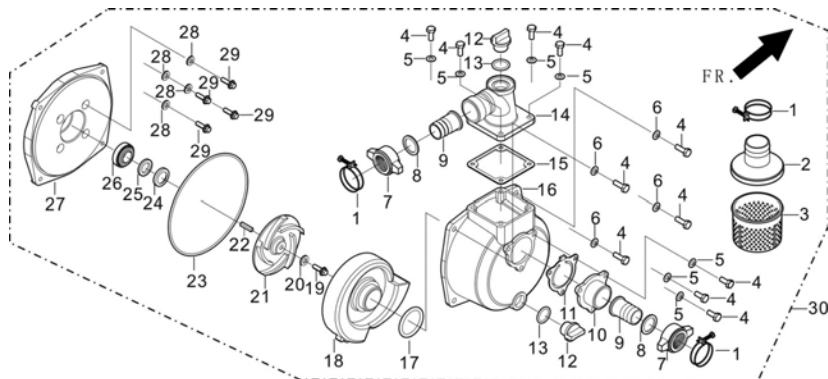

| NUMBER | DESCRIPTION             | PART NUMBER        |
|--------|-------------------------|--------------------|
| 1      | HOSE CLIP               | ZGGMQGZ804530F6801 |
| 2      | STRAINER COVER          | ZGGMQGZ804530F6802 |
| 3      | STRAINER                | ZGGMQGZ804530F6803 |
| 4      | BOLT                    | ZGGMQGZ804530F6804 |
| 5      | WASHER                  | ZGGMQGZ804530F6805 |
| 6      | WASHER                  | ZGGMQGZ804530F6806 |
| 7      | SCREW RING RETAINING    | ZGPF75F6807        |
| 8      | HOSE SEAL               | ZGPF75F6808        |
| 9      | HOSE SPIGOT 3"          | ZGPF75F6809        |
| 10     | WATER INLET             | ZGGMQGZ804530F6810 |
| 11     | INLET WATER GASKET      | ZGGMQGZ804530F6811 |
| 12     | THREAD PLUG             | ZGGMQGZ804530F6812 |
| 13     | SCREW PLUG WASHER       | ZGGMQGZ804530F6813 |
| 14     | WATER OUTLET            | ZGGMQGZ804530F6814 |
| 15     | OUTLET GASKET           | ZGGMQGZ804530F6815 |
| 16     | PUMP BODY               | ZGGMQGZ804530F6816 |
| 17     | WHORL CASE SEALING RING | ZGGMQGZ804530F6817 |
| 18     | WHORL CASE              | ZGGMQGZ804530F6818 |
| 19     | BOLT                    | ZGGMQGZ804530F6819 |

|    |                          |                    |
|----|--------------------------|--------------------|
| 20 | WASHER                   | ZGGMQGZ804530F6820 |
| 21 | WATER PUMP IMPELLER      | ZGGMQGZ804530F6821 |
| 22 | KEY                      | ZGGMQGZ804530F6822 |
| 23 | WATER PUMP JOINT CUSHION | ZGGMQGZ804530F6823 |
| 24 | IMPELLER SEAL            | ZGGMQGZ804530F6824 |
| 25 | PORCELAIN SEAL           | ZGGMQGZ804530F6825 |
| 26 | MECHANISM SEAL ASSEMBLY  | ZGGMQGZ804530F6826 |
| 27 | WATER PUMP JOINT         | ZGGMQGZ804530F6827 |
| 28 | WASHER                   | ZGGMQGZ804530F6828 |
| 29 | BOLT                     | ZGGMQGZ804530F6829 |
| 30 | WATER PUMP ASSEMBLY      | ZGGMQGZ804530F6830 |

## ENGINE FRAME ASSEMBLY

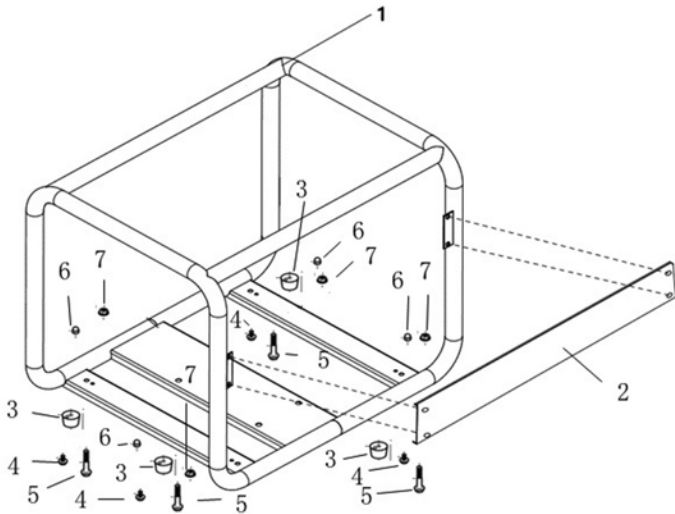

| NUMBER | DESCRIPTION           | PART NUMBER                |
|--------|-----------------------|----------------------------|
| 1      | ENGINE FRAME ASSEMBLY | ZG51100V010110H700         |
| 2      | DECORATIVE FRAME      | ZG210GM720423-0002         |
| 3      | FEET                  | ZG51014HY450110GMQGZ804525 |
| 4      | BOLT                  | ZG90001061201              |
| 5      | BOLT                  | ZG90001085001              |
| 6      | NUT                   | ZG90305060031              |
| 7      | NUT                   | ZG90327080031              |

# DECLARATION OF CONFORMITY



**Clarke**  
INTERNATIONAL  
Hemmel Street, Epping, Essex CM16 4LG

## DECLARATION OF CONFORMITY

This is an important document and should be retained.

**Product Description:** 3" Full Trash Water Pump (Petrol Powered)  
**Model number(s):** PFF75A  
**Serial / batch Number:** N/A  
**Date of Issue:** 14/01/2020  
**(Noise Conformity)**  
**Notified Body:** N/A

**Technical Documentation Holder:** Alan Pond  
Clarke International  
2a Shrubland Road  
London E10 7NB  
UK

**Conformity Assessment Procedure:** to 2000/14/EC Annex V  
**Manufacturer:** Clarke International  
**Noise Related Value:** 4.4kW  
**Measured Sound Power Level:** 103dB  
**Guaranteed Sound Power Level:** 105dB

DOC\_PFF75A Water Pump (11-68801-2)

Page 1 of 2



**Clarke**  
INTERNATIONAL  
Hemmel Street, Epping, Essex CM16 4LG

## DECLARATION OF CONFORMITY

This is an important document and should be retained.

**We hereby declare that this product(s) complies with the following directive(s):**  
2014/30/EU *Electromagnetic Compatibility Directive.*  
2006/42/EC *Machinery Directive.*  
2000/14/EC *Noise Emissions Directive, (amended by 2005/88/EC).*  
2016/1628 *Regulation (EU) Emission of Gaseous Particulates (with amendments).*

**The following standards have been applied to the product(s):**

*EN ISO 14982:2009, EN 609:1996+A1:2009+AC:2010, EN ISO 12100:2010, EN ISO 3744:2010.*

The technical documentation required to demonstrate that the product(s) meet(s) the requirement(s) of the aforementioned directive(s) has been compiled and is available for inspection by the relevant enforcement authorities.

The CE mark was first applied in: 2020

**Signed:**

  
J.A. Clarke  
Director

DOC\_PFF75A Water Pump (11-68801-2)

Page 2 of 2

# A SELECTION FROM THE VAST RANGE OF

# Clarke®

## QUALITY PRODUCTS

### AIR COMPRESSORS

From DIY to industrial, Plus air tools, spray guns and accessories.

### GENERATORS

Prime duty or emergency standby for business, home and leisure.

### POWER WASHERS

Hot and cold, electric and engine driven - we have what you need

### WELDERS

Mig, Arc, Tig and Spot. From DIY to auto/industrial.

### METALWORKING

Drills, grinders and saws for DIY and professional use.

### WOODWORKING

Saws, sanders, lathes, mortisers and dust extraction.

### HYDRAULICS

Cranes, body repair kits, transmission jacks for all types of workshop use.

### WATER PUMPS

Submersible, electric and engine driven for DIY, agriculture and industry.

### POWERTOOLS

Angle grinders, cordless drill sets, saws and sanders.

### STARTERS/CHARGERS

All sizes for car and commercial use.



**PARTS & SERVICE: 0208 988 7400**

**E-mail: [Parts@clarkeinternational.com](mailto:Parts@clarkeinternational.com) or [Service@clarkeinternational.com](mailto:Service@clarkeinternational.com)**

**SALES: UK 01992 565333 or Export 00 44 (0)1992 565335**

**Clarke® INTERNATIONAL** Hemnall Street, Epping, Essex CM16 4LG  
[www.clarkeinternational.com](http://www.clarkeinternational.com)