

KS 2610 MT 1~ 233

Portable pumps ideal for applications in which the water or liquid contains concentrations of abrasives when clogging problems can occur



Technical specification



Curves according to: Water, pure [100%], 4 °C, 999.9 kg/m³, 1.5692 mm²/s

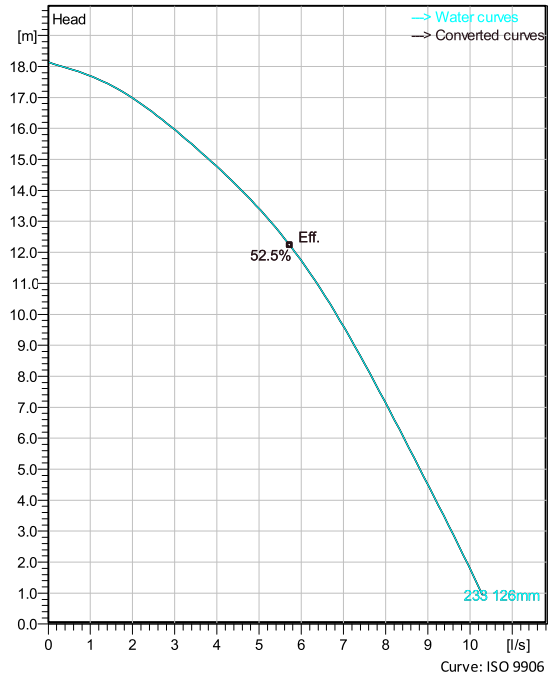

Configuration

Motor number K2610.160 13-10-2BB-W 1.4KW	Installation type S - Portable Semi permanent, Wet
Impeller diameter 126 mm	Discharge diameter 50 m

Pump information

Impeller diameter 126 mm
Discharge diameter 50 m
Inlet diameter 72 mm
Maximum operating speed 2845 rpm
Number of blades 2
Max. fluid temperature 40 °C

Materials

Impeller Hard-Iron

Project
Block

Created by Joshua Harvey
Created on 2/9/2021 **Last update** 2/9/2021

KS 2610 MT 1~ 233

Technical specification



Motor - General

Motor number K2610.160 13-10-2BB-W 1.4KW	Phases 1~	Rated speed 2845 rpm	Rated power 1.4 kW
ATEX approved No	Number of poles 2	Rated current 7.8 A	Stator variant 1
Frequency 50 Hz	Rated voltage 230 V	Insulation class F	Type of Duty S1
Version code 160			

Motor - Technical

Power factor - 1/1 Load 0.98	Motor efficiency - 1/1 Load 79.5 %	Total moment of inertia 0.0018 kg m ²	Starts per hour max. 15
Power factor - 3/4 Load 0.98	Motor efficiency - 3/4 Load 78.5 %	Starting current, direct starting 32 A	
Power factor - 1/2 Load 0.97	Motor efficiency - 1/2 Load 73.5 %	Starting current, star-delta 10.7 A	

Project
Block

Created by Joshua Harvey
Created on 2/9/2021 Last update 2/9/2021

KS 2610 MT 1~ 233

Performance curve



Duty point

Flow Head

Curves according to: Water, pure [100%], 4 °C, 999.9 kg/m³, 1.5692 mm²/s

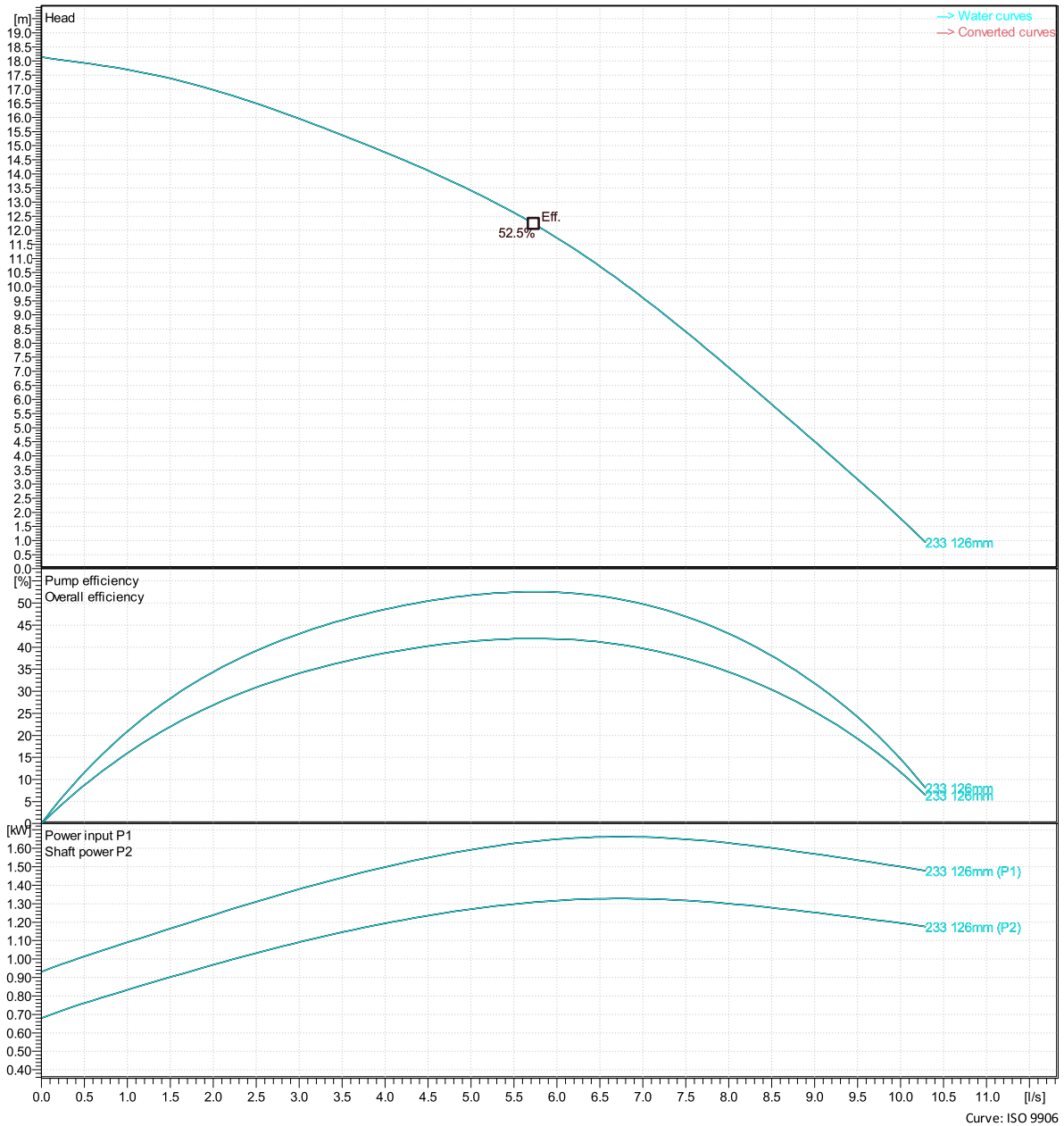

Curve: ISO 9906

Project
Block

Created by Joshua Harvey
Created on 2/9/2021 Last update 2/9/2021

KS 2610 MT 1~ 233

Duty Analysis



Curves according to: Water, pure [100%]; 4°C; 999.9kg/m³; 1.5692mm²/s

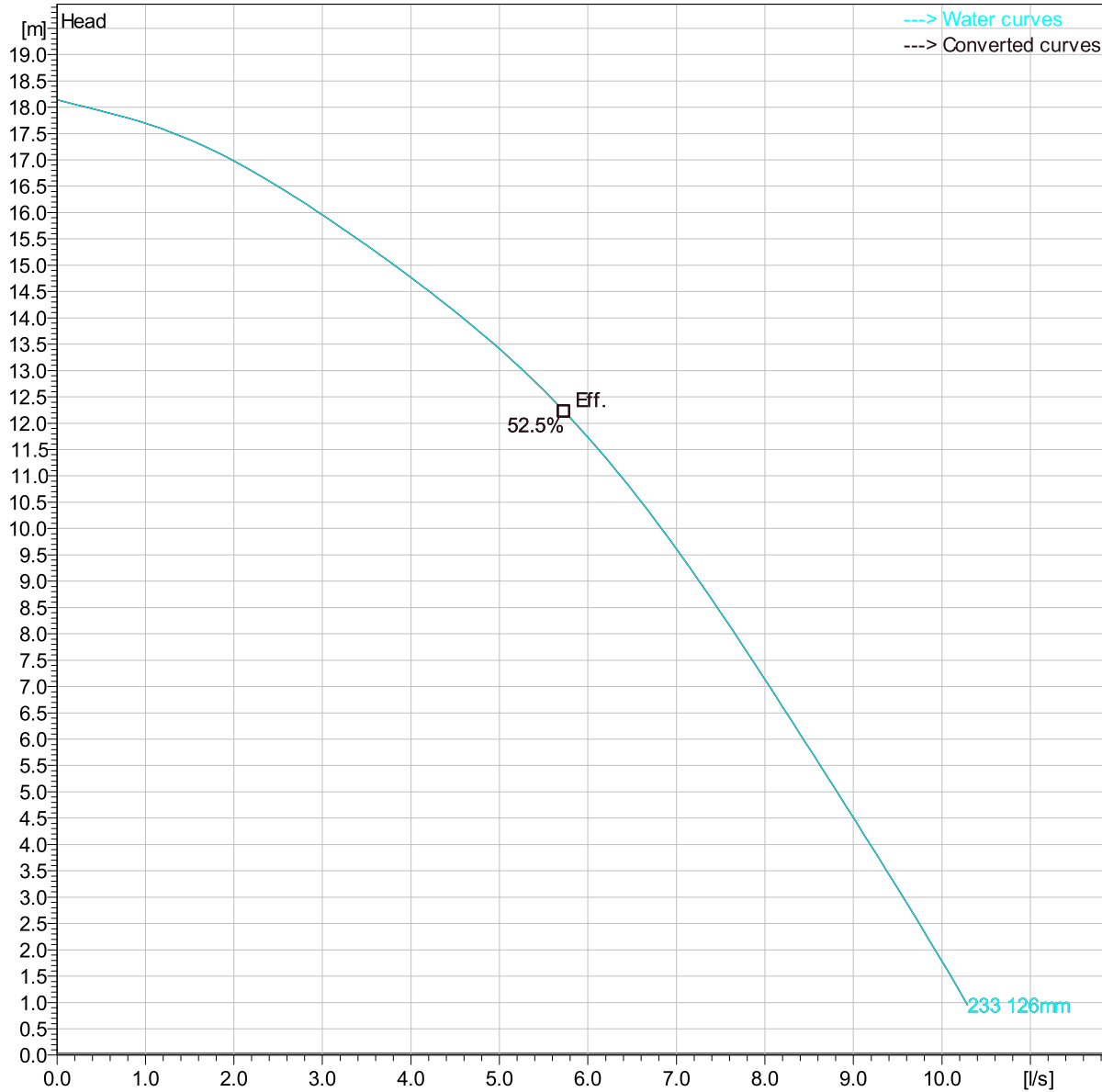

Operating characteristics

Pumps / Systems	Flow	Head	Shaft power	Flow	Head	Shaft power	Hydr.eff.	Specific Energy	NPSHre

Project	Created by	Joshua Harvey
Block	Created on	2/9/2021
	Last update	2/9/2021

KS 2610 MT 1~ 233

Dimensional drawing

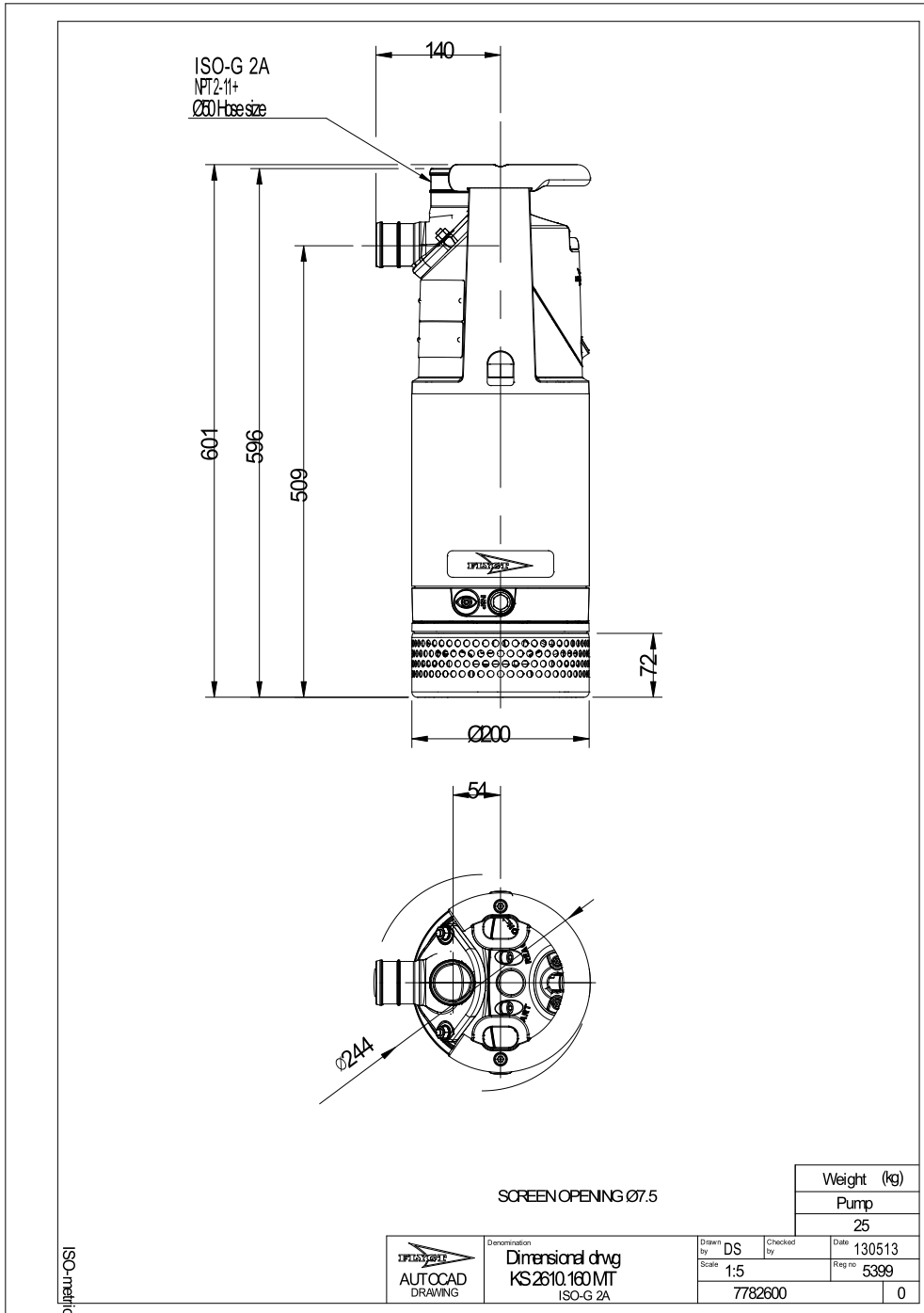

Project
Block

Created by Joshua Harvey
Created on 2/9/2021 Last update 2/9/2021