



DRAPER[®]

SURFACE MOUNTED WATER PUMPS

10461, 98922, 98923.



These instructions accompanying the product are the original instructions. This document is part of the product, keep it for the life of the product passing it on to any subsequent holder of the product. Read all these instructions before assembling, operating or maintaining this product.

This manual has been compiled by Draper Tools describing the purpose for which the product has been designed, and contains all the necessary information to ensure its correct and safe use. By following all the general safety instructions contained in this manual, it will ensure both product and operator safety, together with longer life of the product itself.

All photographs and drawings in this manual are supplied by Draper Tools to help illustrate the operation of the product.

Whilst every effort has been made to ensure the accuracy of information contained in this manual, the Draper Tools policy of continuous improvement determines the right to make modifications without prior warning.

1. INTRODUCTION

1.1 INTRODUCTION:

USER MANUAL FOR: SURFACE MOUNTED WATER PUMPS.

Stock No's: 10461, 98922, 98923.

Part No's: SP77, SP90MS, SP53.

1.2 REVISIONS:

Date first published June 2019.

As our user manuals are continually updated, users should make sure that they use the very latest version.

Downloads are available from: <http://drapertools.com/manuals>

Draper Tools Limited
Hursley Road
Chandler's Ford
Eastleigh
Hampshire
SO53 1YF
UK

Website: drapertools.com

Product Helpline: +44 (0) 23 8049 4344

General Fax: +44 (0) 23 8026 0784

1.3 UNDERSTANDING THIS MANUALS SAFETY CONTENT:

WARNING! – Information that draws attention to the risk of injury or death.

CAUTION! – Information that draws attention to the risk of damage to the product or surroundings.

1.4 COPYRIGHT © NOTICE:

Copyright © Draper Tools Limited.

Permission is granted to reproduce this publication for personal and educational use only. Commercial copying, redistribution, hiring or lending is prohibited.

No part of this publication may be stored in a retrieval system or transmitted in any other form or means without written permission from Draper Tools Limited.

In all cases this copyright notice must remain intact.

2. CONTENTS

1. TITLE PAGE

1.1 INTRODUCTION.....	2
1.2 REVISION HISTORY	2
1.3 UNDERSTANDING THIS MANUAL	2
1.4 COPYRIGHT NOTICE.....	2

2. CONTENTS.....	3
-------------------------	----------

3. WARRANTY

3.1 WARRANTY.....	4
-------------------	---

4. INTRODUCTION

4.1 SCOPE.....	5
4.2 SPECIFICATION	5
4.3 HANDLING AND STORAGE.....	5

5. HEALTH AND SAFETY INFORMATION

5.1 GENERAL SAFETY INSTRUCTIONS FOR POWER TOOL USE	6
– 1) Work area safety	6
– 2) Electrical safety	6
– 3) Personal safety	6
– 4) Power tool use and care	7
– 5) Service	7
5.2 SPECIFIC SAFETY INSTRUCTION FOR PUMP USE.....	7
5.3 CONNECTION TO THE POWER SUPPLY	8

6. TECHNICAL DESCRIPTION

6.1 IDENTIFICATION	9
--------------------------	---

7. UNPACKING AND CHECKING

7.1 PACKAGING	10
7.2 WHAT'S IN THE BOX?.....	10

8. ASSEMBLY

8.1 CONNECT HOSES	11
-------------------------	----

9. OPERATING INSTRUCTIONS

9.1 PUMP OPERATION	12
9.2 PUMPING DISTANCE AND VOLUME	12
9.3 CONNECTING TO POWER VIA RCD	12

10. TROUBLESHOOTING	13
----------------------------------	-----------

11. EXPLANATION OF SYMBOLS

11.1 EXPLANATION OF SYMBOLS	14
-----------------------------------	----

12. DISPOSAL

12.1 DISPOSAL	15
---------------------	----

DECLARATION OF CONFORMITY	ENCLOSED
--	-----------------

3. WARRANTY

3.1 WARRANTY

Draper tools have been carefully tested and inspected before shipment and are guaranteed to be free from defective materials and workmanship.

Should the tool develop a fault, please return the complete tool to your nearest distributor or contact

Draper Tools Limited, Chandler's Ford, Eastleigh, Hampshire, SO53 1YF. England.

Telephone Sales Desk: (023) 8049 4333 or Product Help Line (023) 8049 4344.

A proof of purchase **must** be provided with the tool.

If upon inspection it is found that the fault occurring is due to defective materials or workmanship, repairs will be carried out free of charge. This warranty period covering labour is 12 months from the date of purchase except where tools are hired out when the warranty period is 90 days from the date of purchase. The warranty is extended to 24 months for parts only. This warranty does not apply to any consumable parts, any type of battery or normal wear and tear, nor does it cover any damage caused by misuse, careless or unsafe handling, alterations, accidents, or repairs attempted or made by any personnel other than the authorised Draper warranty repair agent.

Note: If the tool is found not to be within the terms of warranty, repairs and carriage charges will be quoted and made accordingly.

This warranty applies in lieu of any other warranty expressed or implied and variations of its terms are not authorised.

Your Draper warranty is not effective unless you can produce upon request a dated receipt or invoice to verify your proof of purchase within the warranty period.

Please note that this warranty is an additional benefit and does not affect your statutory rights.

Draper Tools Limited.

4. INTRODUCTION

4.1 SCOPE

This machine was designed for pumping clear water. It is ideally suited to pumping out garden ponds where the water is free of debris.

4.2 SPECIFICATION

Stock No. 10461 98922 98923

Part No. SP77 SP90MS SP53

Motor:

Rated voltage 230V 230V 230V

Rated frequency 50Hz 50Hz 50Hz

Rated input 1100W 1100W 800W

Output aperture size 25mm 25mm 25mm

Max. flow rate 76L/min 90L/min 53L/min

Max. head height 45M 46M 38M

Max. Particle Size 1mm 1mm 1mm

Degree of protection against moisture IPX4 IPX4 IPX4

Warning: This product must be used in conjunction with a residual current device (RCD)

4.3 HANDLING AND STORAGE

This surface mounted water pump is designed to be moved to different locations. Ensure it is always operated on a level surface.

5. HEALTH AND SAFETY INFORMATION

Have this tool repaired by a qualified person. This tool is designed to conform to the relevant international and local standards and as such should be maintained and repaired by someone qualified; using only original parts supplied by the manufacturer: This will ensure the tool remains safe to use.

5.1 GENERAL SAFETY INSTRUCTIONS FOR POWER TOOL USE

Warning: Read all safety warnings and all instructions. Failure to follow the warnings and instructions may result in electric shock, fire and/or serious injury.

Save all warnings and instructions for future reference.

The term "power tool" in the warnings refers to your mains-operated (corded) power tool or battery-operated (cordless) power tool.

1) Work area safety

- a) Keep work area clean and well lit. Cluttered or dark areas invite accidents.
- b) Do not operate power tools in explosive atmospheres, such as in the presence flammable liquids, gases or dust. Power tools create sparks which may ignite the dust or fumes.
- c) Keep children and bystanders away while operating a power tool. Distractions can cause you to lose control.

2) Electrical safety

- a) Power tool plugs must match the outlet. Never modify the plug in any way. Do not use any adaptor plugs with earthed (grounded) power tools. Unmodified plugs and matching outlets will reduce risk of electric shock.
- b) Avoid body contact with earthed or grounded surfaces, such as pipes, radiators, ranges and refrigerators. There is an increased risk of electric shock if your body is earthed or grounded.
- c) Do not expose power tools to rain or wet conditions. Water entering a power tool will increase the risk of electric shock.
- d) Do not abuse the cord. Never use the cord for carrying, pulling or unplugging the power tool. Keep cord away from heat, oil, sharp edges or moving parts. Damaged or entangled cords increase the risk of electric shock.
- e) When operating a power tool outdoors, use an extension cord suitable for outdoor use. Use of a cord suitable for outdoor use reduces the risk of electric shock.
- f) If operating a power tool in a damp location is unavoidable, use a residual current device (RCD) protected supply. Use of an RCD reduces the risk of electric shock.

3) Personal safety

- a) Stay alert, watch what you are doing and use common sense when operating a power tool. Do not use a power tool while you are tired or under the influence of drugs, alcohol or medication. A moment of inattention while operating power tools may result in serious personal injury.
- b) Use personal protective equipment. Always wear eye protection. Protective equipment such as dust mask, non-skid safety shoes, hard hat, or hearing protection used for appropriate conditions will reduce personal injuries.
- c) Prevent unintentional starting. Ensure the switch is in the off-position before connecting to power source and/or battery pack, picking up or carrying the tool. Carrying power tools with your finger on the switch or energising power tools that have the switch on invites accidents.

5. HEALTH AND SAFETY INFORMATION

3) Personal safety continued...

- e) Do not overreach. Keep proper footing and balance at all times. This enables better control of the power tool in unexpected situations.
- f) Dress properly. Do not wear loose clothing or jewellery. Keep your hair, clothing and gloves away from moving parts. Loose clothes, jewellery or long hair can be caught in moving parts.

4) Power tool use and care

- a) Do not force the power tool. Use the correct power tool for your application. The correct power tool will do the job better and safer at the rate for which it was designed.
- b) Do not use the power tool if the switch does not turn it on and off. Any power tool that cannot be controlled with the switch is dangerous and must be repaired.
- c) Disconnect the plug from the power source and/or the battery pack from the power tool before making any adjustments, changing accessories, or storing power tools. Such preventive safety measures reduce the risk of starting the power tool accidentally.
- d) Store idle power tools out of the reach of children and do not allow persons unfamiliar with the power tool or these instructions to operate the power tool.
Power tools are dangerous in the hands of untrained users.
- e) Maintain power tools. Check for misalignment or binding of moving parts, breakage of parts & any other condition that may affect the power tool's operation. If damaged, have the power tool repaired before use. Many accidents are caused by poorly maintained power tools.

5) Service

- a) Have your power tool serviced by a qualified repair person using only identical replacement parts. This will ensure that the safety of the power tool is maintained.

5.2 SPECIFIC SAFETY INSTRUCTIONS FOR PUMP USE

Have this tool repaired by a qualified person. This tool is designed to conform to the relevant international and local standards and as such should be maintained and repaired by someone qualified; using only original parts supplied by the manufacturer: This will ensure the tool remains safe to use.

1. Before connecting to the power supply:
 - i. A residual current circuit breaker (RCD) must be used for all applications.
 - ii. The electrical supply should be the same as stated on the rating plate.
2. Surface mounted pumps should always be transported and stored horizontally on the base plate.
3. Always ensure that hands are dry when connecting and disconnecting the power supply.
4. Never operate the pump dry.
5. The area being pumped should be kept clear, nobody should enter area while pump is operating.

5. HEALTH AND SAFETY INFORMATION

5.3 CONNECTION TO THE POWER SUPPLY

Caution: Risk of electric shock. Do not open.

These machines come supplied with a UK standard 3 pin plug fitted. Designed for connection to a domestic power supply rated at 230V AC.

Because it is constructed mostly of metal parts, it is a Class 1 machine; meaning, it must have an earth connection in the power supply. This is to prevent electrocution in the event of a failure.

Apart from replacing the fuse in the plug, no other electrical work is recommended on this produce.

IMPORTANT

If using an extension lead, follow the instructions that came with your lead regarding maximum load while cable is wound. If in doubt, ensure that the entire cable is unwound. Using a coiled extension lead will generate heat which could melt the lead and cause a fire.

6. TECHNICAL DESCRIPTION

6.1 IDENTIFICATION

- ① Discharge screw.
- ② Inlet (suction pipe).
- ③ Priming screw.
- ④ Outlet (pressure pipe).
- ⑤ On/off switch.
- ⑥ Approved 3 pin non-rewireable moulded plug and cable (not fitted to 110V models)
- ⑦ Outlet elbow adaptor.



7. UNPACKING & CHECKING

7.1 PACKAGING

Carefully remove the machine from the packaging and examine it for any sign of damage that may have happened during shipping. Lay the contents out and check them against the parts shown below. If any part is damaged or missing; please contact the Draper Helpline (the telephone number appears on the Title page) and do not attempt to use the machine.

The packaging material should be retained at least during the guarantee period: in case the machine needs to be returned for repair.

Warning! Some of the packaging materials used may be harmful to children. Do not leave any of these materials in the reach of children.

If any of the packaging is to be thrown away, make sure they are disposed of correctly; according to local regulations.

7.2 WHAT'S IN THE BOX?

As well as the pump; there is a part not fitted or attached to it.

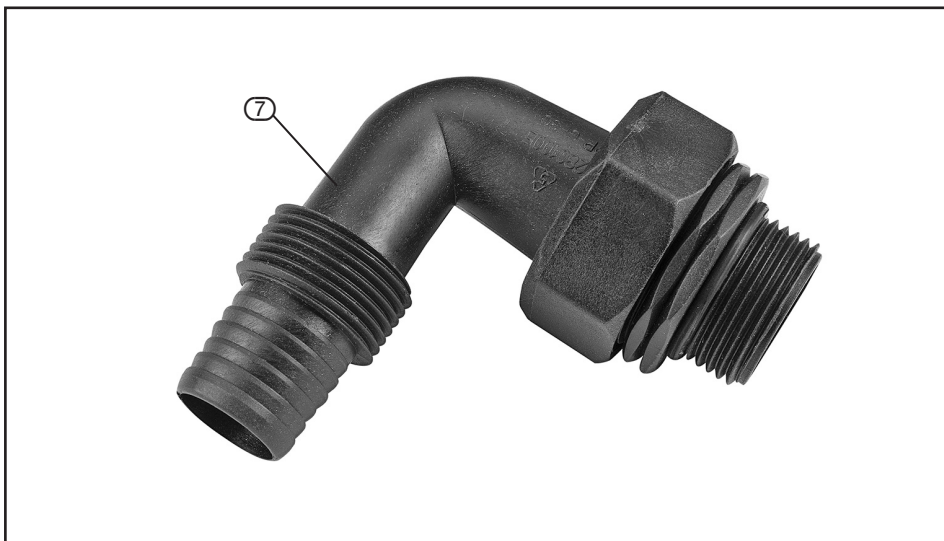

⑦ Outlet elbow adaptor.

8. ASSEMBLY

8.1 CONNECT HOSES- FIGS. 1 - 2

NOTE: Remove the plug from the power supply before carrying out adjustment, servicing or maintenance.

NOTE: This machine will not function without the use of a solid wall suction hose kit.

Connect the suction hose (2.1) into the suction inlet (2).

Connect the outlet elbow adaptor (7) into the outlet (4), and secure an outlet hose (4.1) to the elbow (7) using a suitable hose clip.

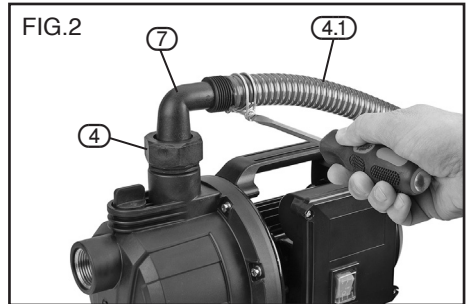
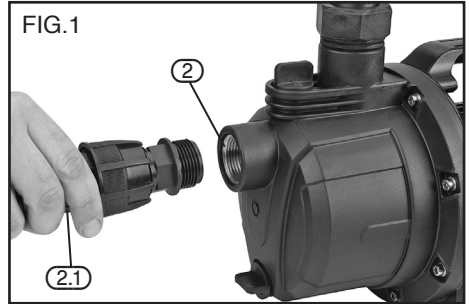

9. PUMP OPERATION

9.1 PUMP OPERATION- FIGS. 3 - 4

Before operating the pump for the first time, it should be primed with water through the priming hole (3.1), the filling operation must be carried out very slowly.

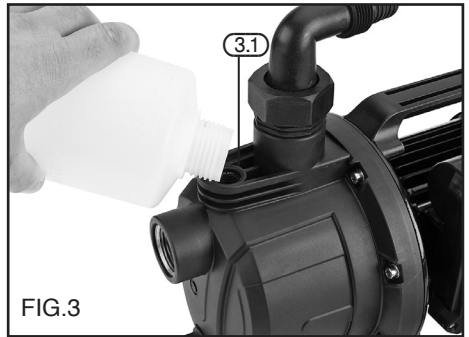

Ensure that the water level is to the maximum. Submerge the filter (3.2) attached to the end of the solid wall suction hose (sold separately) before turning the pump on.

Switch on.

NOTE: If after 1-2 minutes the pump is not pumping water, switch off and repeat the priming operation.

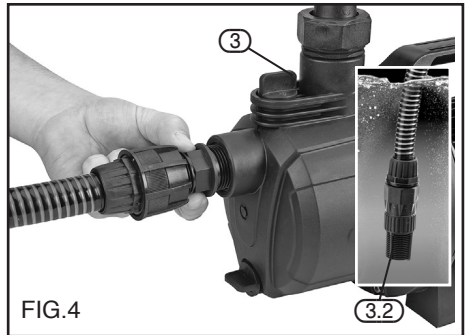

9.2 PUMPING DISTANCE AND VOLUME

Horizontal pumping distance is directly affected by the working head height (Maximum head height minus actual working head height \times factor of 10 equals the approximate horizontal pumping distance in metres using solid delivery hose).

For example:

If the maximum head height is 9.5 metres, minus actual working head height of 5 metres = 4.5 metre \times factor of 10 is 45 metres (approximate pumping distance).

9.3 CONNECTING TO POWER VIA RCD – FIG.5

Once you have the pump safely situated and the float switch adjusted, if required, you are ready to turn on the pump.

Plug your pump into a Residual Current Device (RCD) such as Draper Stock No.69307 (8) or 89301 (9) and connect to your mains supply.

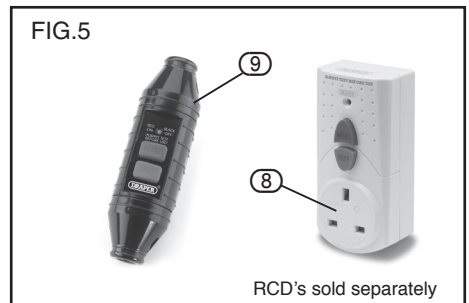

RCD's sold separately

10. TROUBLESHOOTING

10.1 TROUBLESHOOTING CHECKLIST

WARNING:

For your own safety, always turn the main switch on the machine "Off" and remove the plug from the power supply before carrying out any servicing or maintenance.

FAULT	POSSIBLE CAUSE	REMEDY
The pump delivers no water	<ol style="list-style-type: none">1. The suction grid or piping are clogged.2. The impeller is worn or stuck.3. The head height exceeds the pump specification.4. Water level under the suction minimum.	<ol style="list-style-type: none">1. Remove the obstruction.2. Replace the impeller or remove the obstruction.3. Reduce head height.4. Insert into water or dig well to move pump lower.
The flow rate is too low	<ol style="list-style-type: none">1. Make sure the suction grid is not partially clogged.2. Make sure the impeller or delivery pipe are not partially clogged or fouled.3. Flow direction control valve orientation incorrect.	<ol style="list-style-type: none">1. Remove any obstructions.2. Remove any obstructions.3. Check and replace if necessary.
The pump stops running	<ol style="list-style-type: none">1. Intervention of the thermal overload switch.	<ol style="list-style-type: none">1. Make sure the fluid being pumped is not too dense, causing the motor to overheat.2. Make sure the temperature of the water is not too high.3. Make sure there is no solid body obstructing the impeller.4. Power supply doesn't comply with the nameplate's data.

11. EXPLANATION OF SYMBOLS

11.1 EXPLANATION OF SYMBOLS



Single value noise marking.
(Maximum declared
A-Weighted sound power level
in decibels).



**Do not dispose of WEEE*
unsorted municipal waste.**



Warning!
Read the instruction manual.

12. DISPOSAL

12.1 DISPOSAL

- At the end of the machine's working life, or when it can no longer be repaired, ensure that it is disposed of according to national regulations.
- Contact your local authority for details of collection schemes in your area.

In all circumstances:

- Do not dispose of power tools with domestic waste.
- Do not incinerate.
- Do not abandon in the environment.
- Do not dispose of WEEE* as unsorted municipal waste.



■
* Waste Electrical & Electronic Equipment.

CONTACTS

Draper Tools Limited, Hursley Road,
Chandler's Ford, Eastleigh, Hampshire. SO53 1YF. U.K.

Helpline: (023) 8049 4344

Sales Desk: (023) 8049 4333

Internet: drapertools.com

E-mail: sales@drapertools.com

General Enquiries: (023) 8026 6355

Service/Warranty Repair Agent:

For aftersales servicing or warranty repairs, please contact the
Draper Tools Helpline for details of an agent in your local area.

YOUR DRAPER STOCKIST

KCMC0419

©Published by Draper Tools Limited.

No part of this publication may be reproduced, stored in a retrieval system or transmitted in any form or by any means, electronic, mechanical photocopying, recording or otherwise without prior permission in writing from Draper Tools Ltd.