

DAB Monobloc Upstream Kit – 22/28mm

The DAB Monobloc Upstream Kit is a compact unit designed to be installed with accumulator systems.

This unit provides an alternate to the previously used separate kits, saving time on installation.

All offered in on compact kit and necessary to comply with water regulations on the incoming cold main.



Details –

- 3 Year warranty
- Compact Design
- WRAS approved
- Suitable for both 22mm and 28mm installations
- 0-5.5 bar pressure regulation, 3bar pre-set

Dimensions –

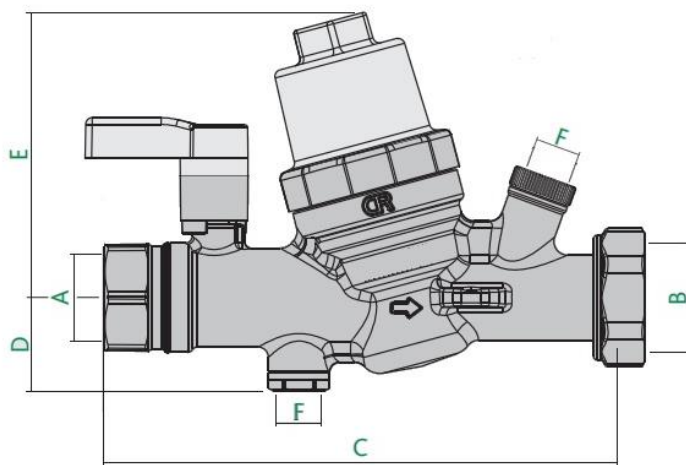

Dimensions

- A - 22/28mm
- B - 22/28mm
- C - 151.2mm
- D - 159.3mm
- E - 108.2mm
- F - Pressure gauge port

Installation -

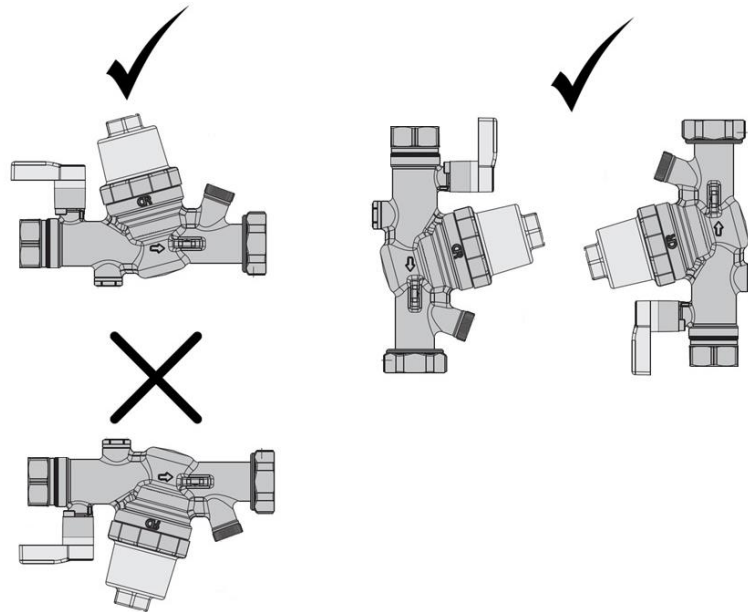

Positioning -

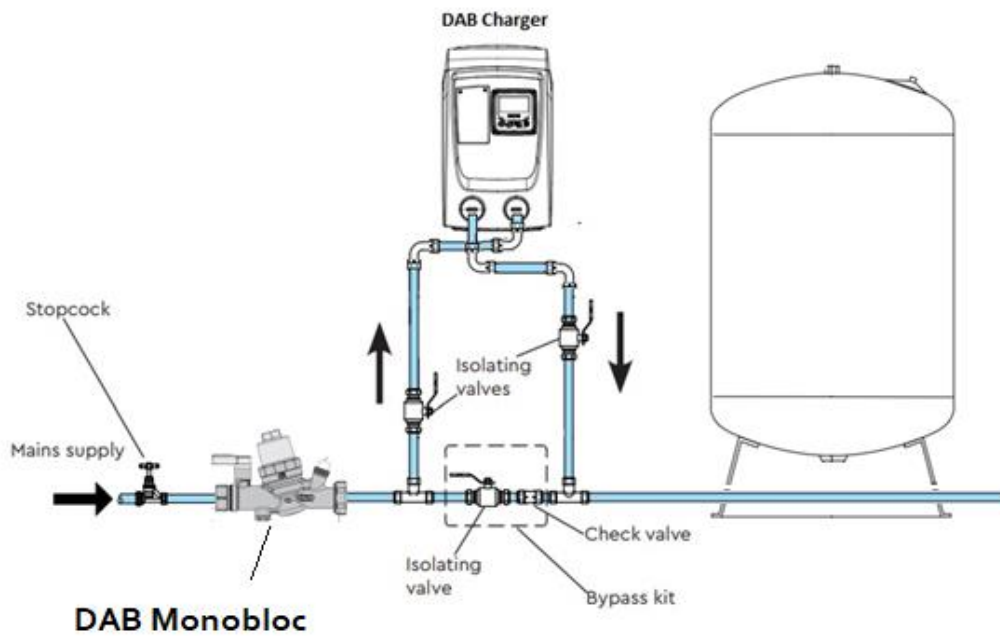

The DAB Monobloc should be installed between the stock cock and system. Before any outlets, taps or pump.
