

Clarke®



PARAFFIN/DIESEL HEATER

MODEL NO: XR60

PART NO: 6931002

OPERATION & MAINTENANCE INSTRUCTIONS



LS0813

INTRODUCTION

Thank you for purchasing this CLARKE product.

Before attempting to use this product, please read this manual thoroughly and follow the instructions carefully. In doing so you will ensure the safety of yourself and that of others around you, and you can look forward to your purchase giving you long and satisfactory service.

This is a multi-fuel (Diesel or paraffin), forced air heater. It's intended use is primarily temporary heating of buildings under construction, alteration or repair.

Forced Air means that a blower or fan pushes the air through the heater. Proper combustion depends upon this air flow; therefore, the heater must not be revised, modified or operated with parts removed or missing. Likewise, safety systems must not be circumvented or modified in order to operate the heater.

GUARANTEE

This product is guaranteed against faulty manufacture for a period of 12 months from the date of purchase. Please keep your receipt which will be required as proof of purchase.

This guarantee is invalid if the product is found to have been abused or tampered with in any way, or not used for the purpose for which it was intended.

Faulty goods should be returned to their place of purchase, no product can be returned to us without prior permission.

This guarantee does not effect your statutory rights.

UNPACKING

1. Remove heater from carton.
2. Remove all protective material which may have been applied to the heater for shipment.



SAFETY WARNINGS

Your safety is important to you and to others, so please read these instructions before you operate this heater.

1. Failure to comply with the precautions and instructions provided with this heater can result in death, serious bodily injury and property loss or damage from the hazards of fire, explosion, burns, asphyxiation, carbon monoxide poisoning, and/or electric shock.
2. Only persons who understand and follow the instructions should use or service this heater.
3. When used, the heater should rest on a suitable insulating material at least 1 inch thick and extending 3 feet or more beyond the heater in all directions
4. Keep any combustible materials, such as curtains and furniture, a safe distance away from the heater. Never use the heater in spaces which do or may contain volatile or airborne combustibles, or products such as petrol, solvents, paint thinners, dust particles or unknown chemicals.
5. Not for home or recreational vehicle use.
6. Do not use petrol or volatile fuels.
7. Disconnect the heater from the power supply before adding fuel.
8. Always fill outdoors away from any open flame or other sources of ignition.
9. Do not use an external fuel source.
10. Do not operate the heater where flammable liquids or vapours may be present.
11. Do not start the heater when the chamber is hot.
12. Plug the electrical cable into a properly grounded mains socket.

SAFETY SYMBOLS

The following symbols appear on the unit.

	Hot Surface, do not touch		High Voltage
---	---------------------------	---	--------------

GENERAL PRECAUTIONS

VENTILATION

Even though this heater operates very close to 100 percent combustion efficiency, it still produces small amounts of carbon monoxide.

Carbon monoxide (CO) is toxic.

CO can build up in a confined spaces and failure to provide adequate ventilation can be fatal.

The early symptoms of asphyxiation caused by inadequate ventilation are:

- headache
- dizziness
- nausea
- dry mouth or sore throat

Be sure to follow all warnings in this manual.

WE RECOMMEND THE USE OF A CARBON MONOXIDE DETECTOR

BYSTANDERS

When the heater is to be operated in the presence of other people the user is responsible for informing those present of the safety precautions and of the hazards involved.

ELECTRICAL CONNECTIONS



WARNING: READ THESE ELECTRICAL SAFETY INSTRUCTIONS THOROUGHLY BEFORE CONNECTING THE PRODUCT TO THE MAINS SUPPLY.

Connect the mains lead to a standard, 230 Volt (50Hz) electrical supply through an approved BS1363/A plug fitted with a BS1362 13 amp fuse.

If the plug has to be changed because of damage, it must be removed and a replacement fitted, following the wiring instructions shown below. The old plug must be discarded safely, as insertion into a power socket could cause an electrical hazard.



**WARNING: WIRES IN THE MAINS LEAD ARE COLOURED IN ACCORDANCE WITH THE FOLLOWING CODE:
GREEN/YELLOW = EARTH, BLUE = NEUTRAL, BROWN = LIVE.**

- The BLUE wire must be connected to the terminal which is marked N or coloured black.
- The BROWN wire must be connected to the terminal which is marked L or coloured red.
- The YELLOW AND GREEN wire must be connected to the terminal which is marked E or \perp or coloured green.

Plug must be BS1363/A approved.

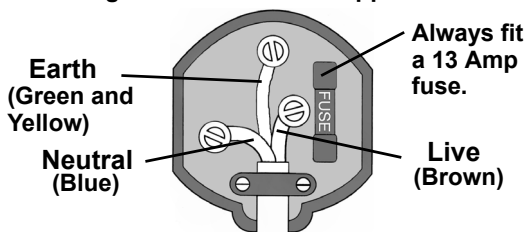

Ensure that the outer sheath of the cable is firmly held by the clamp

We strongly recommend that this machine is connected to the mains supply through a Residual Current Device (RCD)

If you are not sure, consult a qualified electrician. DO NOT try to do any repairs.

SAFETY PRECAUTIONS

1. Check the heater thoroughly for damage. Never operate a damaged heater.
2. Do not modify the heater or operate a heater which has been modified from its original condition.
3. This heater is for indoor use only.
4. Use in well ventilated spaces and provide at least 2 sq. ft. (0.19 sq.m.) of opening near the floor and 2 sq. ft. (0.19 sq. m.) near the ceiling directly to outdoors. Increase air openings for each additional heater.
5. Always keep combustibles, like paper and wood at least 8 ft. (2.4 m) from the front of the heater and 3 ft. (1 m) from the top, sides and rear.
6. Locate the heater 10 ft. (3 m) from canvas or plastic coverings and secure them to prevent movement.



CAUTION: DUE TO THE HIGH SURFACE AND EXHAUST TEMPERATURES, ADULTS AND CHILDREN MUST KEEP CLEAR OF THE UNIT TO AVOID BURNS OR CLOTHING IGNITION.

7. Make sure that the heater is not directly exposed to rain or water spray.
8. Never use in living spaces and/or where children may be present.
9. Operate only on a stable, level surface.
10. Do not use with ductwork. Do not restrict air inlet or exit.
11. Do not move or service the heater while hot or in operation.
12. Use only in accordance with local regulations and relevant building codes.
13. The heater is not to be used by children or persons with reduced physical, sensory or mental capabilities, or lack of experience and knowledge.
14. If the supply cable is damaged, it must be replaced by the manufacturer, its service agent, or similarly qualified persons in order to avoid a hazard.

PREPARATION

FUELS

Diesel or paraffin are the only fuels that should be used in this heater.

FILLING THE FUEL TANK

IMPORTANT: Before filling the fuel tank the first time or after extended storage periods, drain the fuel tank of any moisture or condensation.

1. Follow all of the "Safety Precautions".
2. Remove the fuel cap.

NOTE: If you lose the fuel cap a replacement must be obtained before use, this is available from your local Clarke service department part number GF0K070000.

3. Fill the fuel tank with clean diesel or paraffin.

- In cold weather, condensation may develop in the tank if the tank is empty and it is recommended that a tablespoon of de-icer be added for each gallon of fuel in the tank.
- When filling the heater, make sure that the heater is level and do not overfill. Use a funnel or can with a long fill spout.
- Fill with a minimum of 4 litres of fuel.

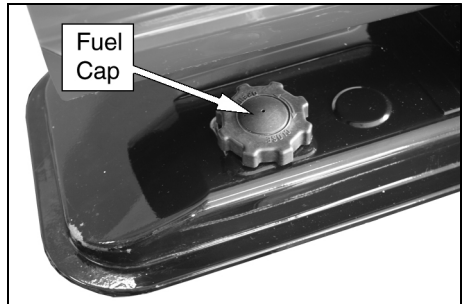

LOCATION

- Locate heater at a safe distance from combustible materials.
- This heater must not be placed on wooden floors or other combustible materials.
- When used, the heater should rest on suitable insulating material at least 1 inch thick and extending 3 ft. or more beyond the heater in all directions?

OPERATING INSTRUCTIONS

HEATER START UP

1. Make sure power switch is in the OFF position.
2. Turn thermostat to lowest setting.
3. Plug the heater into the mains power supply.
4. Turn the thermostat to highest setting.
5. Start heater by setting the power switch to the ON position.

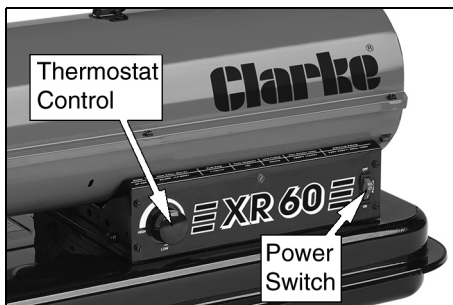

- The switch illuminates in the ON position.

6. Adjust thermostat to desired setting.

NOTE: Heater will cycle on/off to maintain an even temperature.

HEATER SHUT DOWN

1. Set the power switch to the OFF position.
2. For extended shutdown, unplug the heater from the mains supply.

BEFORE STORAGE

- Clean the heater as described in the MAINTENANCE section.
- The manufacturer recommends completely filling the tank with fuel for extended storage to minimize condensation inside the tank.

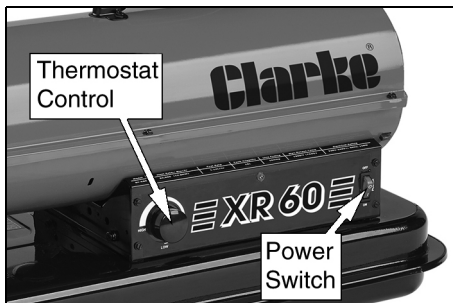

MAINTENANCE, STORAGE AND SERVICING



WARNING: TO PREVENT PERSONAL INJURY, UNPLUG THE HEATER FROM THE MAINS SUPPLY BEFORE SERVICING.

DAILY SCHEDULE

GENERAL

1. Make a general visual inspection of the heater for loose or damaged parts.
2. Check nuts and bolts are secure.
3. Damaged parts should be repaired or replaced before using the heater again.
4. Check heater operation to be sure it is operating normally as follows:
 - The flame is contained within the heater.
 - The flame is essentially yellow.
 - There is no strong disagreeable odor, eye burning or other physical discomfort.
 - There is no smoke or soot internal or external to the heater.
 - There are no unplanned or unexplained shut downs of the heater

REMOVE DUST

Clean the heater twice a season (more often under dusty conditions).

1. Remove accumulated dust from the transformer, burner, motor and fan blades with compressed air.
2. Wipe clean with a clean dry cloth.

FUEL TANK (EVERY 500 HOURS)

Clean twice a season (during frequently used periods, clean twice a month). Drain and flush the fuel tank with clean fuel oil.

FILTERS

Dirty air filters will cause an imbalance in the air-fuel mixture. The best indication that this condition exists is an increase in odour or difficulty getting your heater to ignite. This heater should never be operated without the filters in place. If required, clean the filters as follows.

ACCESSING THE FILTERS

1. Make sure that the plug is removed from the mains supply before carrying out any maintenance.
2. Remove the six screws shown and remove the top cover of the heater.

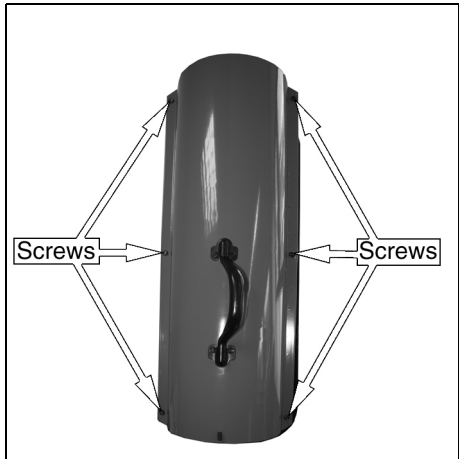

3. Lift out the rear guard.

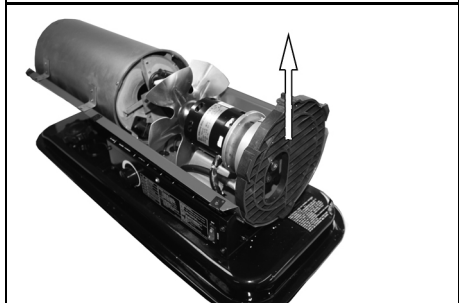

4. Remove the three screws securing the filter cover.
5. Pull the filter cover away from the motor.

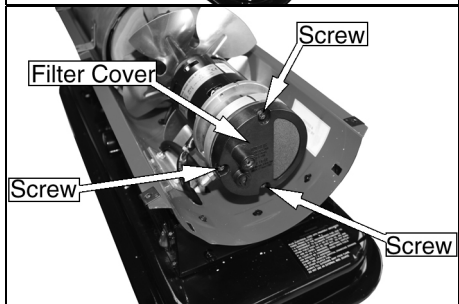

AIR INTAKE FILTER CLEANING

6. To clean the air intake filter.

- Remove and wash the filter element with a mild detergent.
- Dry thoroughly and refit.
- Clean as often as necessary (at least approximately every 500hrs.).
- Do not oil the filter element. If your heater is used where there is considerable dust or dirt.

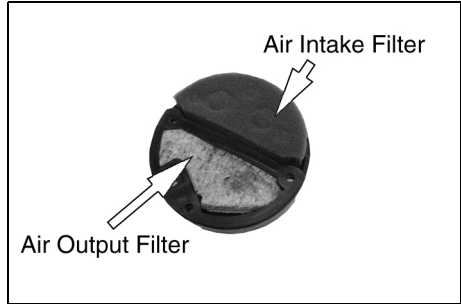

NOTE: If the filter is damaged or extremely dirty, a replacement filter of the same type must be fitted, this is available from your local Clarke service department part number GF50K100406.

AIR OUTPUT FILTER CLEANING

7. To clean the air output filter (Annually or as required)

- Remove the air output filter and tap the contaminated side gently on a solid object to remove contaminates.

NOTE: Compressed air or liquids should not be used to clean this filter.

NOTE: If the filter appears damaged or extremely dirty, replace it with a new filter of the same type must be obtained and fitted this is available from your local Clarke service department part number GF50K100401.

8. Reinstall clean filter in to the filter body in the same position as it was when removed.

9. Replace the filter cover and secure using the screws removed in step 4.

NOTE: When replacing the filter cover, make sure that the gasket is firmly in place and the screws in the filter cover are tight to prevent air leaks. if the gasket is damaged a replacement must be obtained and fitted this is available from your local Clarke service department part number GF50K100407.

10. Refit the rear guard and replace the top cover.

11. Make sure all screws are replaced before use.

STORAGE

Store the heater in a dry location free from fumes or dust.

TROUBLE SHOOTING

LED	OPERATION	TROUBLE SHOOTING
Steady ON	System Check	System performing self test. No action required.
Steady OFF		No action required.
2 Flashes	No flame detected	Heater fails to start. 1. Check fuel level 2. Return to Clarke service department for repair.
3 Flashes	High limit switch failure (unit has overheated)	Make sure heater is cooled down, 1. Make sure that the power switch is set to the OFF position. 2. Wait 5 minutes 3. Start heater by setting the power switch to the ON position.
4 Flashes	Flame sensor Failure	<ul style="list-style-type: none"> • Return to Clarke service department for repair.

WIRING DIAGRAM

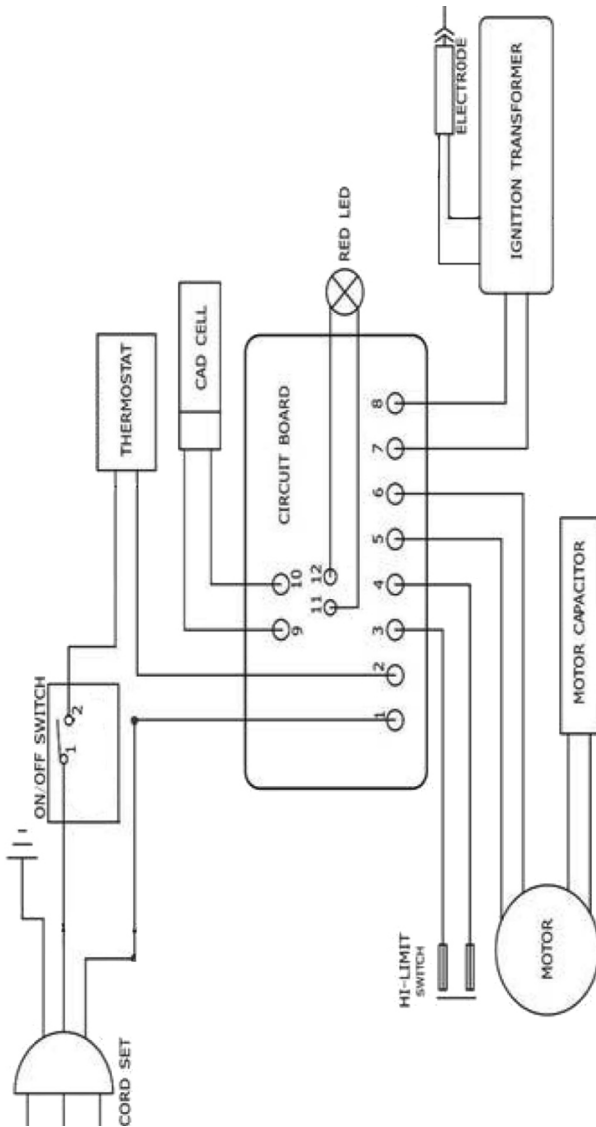

SPECIFICATIONS

Model	XR60
Burn Rate: (Btu/hr.)	50,000
Fuel consumption:	1.6 L/hr.
Approx Running Time:	9.4 hr
Electrical input:	230V~50Hz
Power	166 W
Max.Outlet Temp:	1300°F (704°C)
Fuel Tank Capacity:	15 L
Ignition system:	Electric Ignition
Primary Safety Control:	Flame failure device
Weight (kg)	12.45
Dimensions (DxWxH) mm	774 x 300 x 388

DECLARATION OF CONFORMITY



Clarke[®]
INTERNATIONAL

Hemnall Street, Epping, Essex CM16 4LG

DECLARATION OF CONFORMITY

This is an important document and should be retained.

We hereby declare that this product(s) complies with the following directive(s):

2004/108/EC *Electromagnetic Compatibility Directive.*

2006/95/EC *Low Voltage Equipment Directive.*

2011/65/EU *Restriction of Hazardous substances.*

The following standards have been applied to the product(s):

EN 61000-6-3:2007, EN 61000-6-1:2007, EN 61000-3-2:2006,

EN 61000-3-3:2008, EN 60335-1:2002 +A13:2008, EN 60335-2-102:2006, EN 62233:2008,

EN 13842:2004.

The technical documentation required to demonstrate that the product(s) meet(s) the requirement(s) of the aforementioned directive(s) has been compiled and is available for inspection by the relevant enforcement authorities.

The CE mark was first applied in: 2011

Product Description: Paraffin / Diesel Fired Space Heaters
Model number(s): XR60, XR80, XR110, XR160
Serial / batch Number: N/A
Date of Issue: 15/07/2013

Signed:

J.A. Clarke
Director

A SELECTION FROM THE VAST RANGE OF

Clarke®

QUALITY PRODUCTS

AIR COMPRESSORS

From DIY to industrial, Plus air tools, spray guns and accessories.

GENERATORS

Prime duty or emergency standby for business, home and leisure.

POWER WASHERS

Hot and cold, electric and engine driven - we have what you need

WELDERS

Mig, Arc, Tig and Spot. From DIY to auto/industrial.

METALWORKING

Drills, grinders and saws for DIY and professional use.

WOODWORKING

Saws, sanders, lathes, mortisers and dust extraction.

HYDRAULICS

Cranes, body repair kits, transmission jacks for all types of workshop use.

WATER PUMPS

Submersible, electric and engine driven for DIY, agriculture and industry.

POWER TOOLS

Angle grinders, cordless drill sets, saws and sanders.

STARTERS/CHARGERS

All sizes for car and commercial use.



PARTS & SERVICE: 020 8988 7400

E-mail: Parts@clarkeinternational.com or Service@clarkeinternational.com

SALES: UK 01992 565333 or Export 00 44 (0)1992 565335

Clarke® INTERNATIONAL Hemnall Street, Epping, Essex CM16 4LG
www.clarkeinternational.com