

Champion®

PUMP



SWIMMING POOL PUMP

Model SPPT1

Part No: 7175040

OPERATING & MAINTENANCE INSTRUCTIONS

CE



GC0414

INTRODUCTION

Thank you for purchasing this CLARKE pump.

Before attempting to operate the pump, it is essential that you read this manual thoroughly and carefully follow all instructions given. In doing so you will ensure the safety of yourself and that of others around you, and you can also look forward to the pump giving you long and satisfactory service.

Upon receipt of the product, any damage or deficiency should be reported to your CLARKE dealer immediately.

DESCRIPTION

This centrifugal swimming pool pump is designed for the filtration of small to medium size swimming pools and for pumping clean water only and operating with contaminated or salt water should be avoided.

When used with permanently installed pools, the pump should be fixed in a horizontal position and the use of a non-return valve will facilitate immediate priming. The pump inlet is higher than the impeller inlet so that it can start operating when only the pump body is filled with water.

The SPPT1 incorporates an integral timer which can be set to operate for a pre-determined time between 2 and 24 hrs. The timer has a back up battery to save the settings in case of loss of electrical power, allowing the pump to start again once power is restored.

GUARANTEE

This CLARKE product is guaranteed against faulty manufacture for a period of 12 months from the date of purchase. Please keep your receipt as proof of purchase.

This guarantee is invalid if the product is found to have been abused or tampered with in any way, or not used for its intended purpose.

Faulty goods should be returned to their place of purchase, no product can be returned to us without prior permission.

This guarantee does not effect your statutory rights.

GENERAL SAFETY PRECAUTIONS



WARNING: This swimming pool pump is not a submersible pump. On no account should it ever be immersed in water.



WARNING: Always connect the pump to an earthed power supply via an RCD.

1. **ALWAYS** keep the pump room clean and well lit. Floors should always be kept clear. Cluttered or dark areas invite accidents.
2. **NEVER** over-reach. Keep your proper footing and balance at all times when installing or maintaining the pump.
3. **NEVER** direct any water discharge towards electrical wiring or equipment.
4. **ALWAYS** thoroughly familiarise yourself with this pump & its operation, and follow all instructions in this manual. Never allow persons unfamiliar with these instructions to operate the pump.
5. **ALWAYS** ensure that the pump is properly installed to prevent it from moving during operation, and that the immediate area surrounding the pump is kept clear.
6. **ALWAYS** maintain the pump with care and keep it clean for best / safest performance.
7. **NEVER** use this product if any part is damaged. Have it inspected and repaired by your local Clarke dealer. Always turn the pump off before carrying out any maintenance.
8. **NEVER** modify this pump in any way. Use it ONLY for the purpose for which it is designed.
9. **NEVER** use for pumping flammable liquids or corrosive chemicals. This pump is designed to pump clean water only.
10. **NEVER switch the pump ON when the pool is in use. ALWAYS disconnect the pump from the electrical supply when the pool is in use.**
11. **ALWAYS** have the pump serviced by your local CLARKE dealer, using only identical replacement parts. This will ensure the safety of the pump is maintained. The use of non standard parts could be hazardous.
12. **NEVER** allow the pump to run dry.

Your CLARKE water pump has been designed to give long and trouble free service. If, however, having followed the instructions in this booklet carefully, you encounter problems, take the unit to your local CLARKE dealer.

Please keep these instructions in a safe place for future reference.

ELECTRICAL CONNECTIONS



WARNING! Read these electrical safety instructions thoroughly before connecting the product to the mains supply.

Before switching the product on, make sure that the voltage of your electricity supply is the same as that indicated on the rating plate. This product is designed to operate on 230VAC 50Hz. Connecting it to any other power source may cause damage.

This product may be fitted with a non-rewireable plug. If it is necessary to change the fuse in the plug, the fuse cover must be refitted. If the fuse cover becomes lost or damaged, the plug must not be used until a suitable replacement is obtained.

If the plug has to be changed because it is not suitable for your socket, or due to damage, it should be cut off and a replacement fitted, following the wiring instructions shown below. The old plug must be disposed of safely, as insertion into a mains socket could cause an electrical hazard.



WARNING! The wires in the power cable of this product are coloured in accordance with the following code:

Blue = Neutral

Brown = Live

Yellow & Green = Earth

If the colours of the wires in the power cable of this product do not correspond with the terminal markings of your plug, proceed as follows:

- The wire which is coloured Blue must be connected to the terminal which is marked N or coloured Black.
- The wire which is coloured Brown must be connected to the terminal which is marked L or coloured Red.
- The wire which is coloured Yellow & Green must be connected to the terminal which is marked E or  or coloured Green.

Plug must be BS1363/A approved

Earth
(Green and Yellow)

Neutral
(Blue)

Always fit a 13 Amp fuse.

Live
(Brown)

Ensure that the outer sheath of the cable is firmly held by the clamp

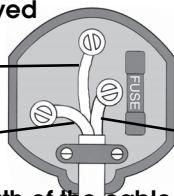

Always connect this product to the mains supply via a Residual Current Device (RCD)

If in any doubt, consult a qualified electrician. DO NOT attempt any repairs yourself.

INSTALLATION

Because of the variety of possible installations, no plumbing accessories are supplied with your pump, however accessories are available from your nearest CLARKE dealer. Contact your CLARKE dealer for further information, or CLARKE International Sales Department on 01992 565333.

Note: It is recommended that the end user should consult a qualified installer if there are any doubts as to the suitability of this product for a particular installation.

IMPORTANT: The pump MUST NOT be connected to the mains power supply until all hose/pipe installation is completed.

INSTALLATION OF THE PUMP

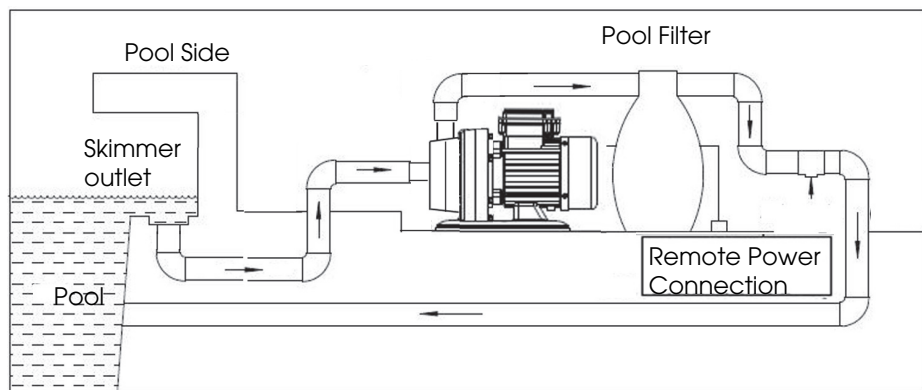

Fig 1

A typical installation of a swimming pool pump is shown in Fig 1. The pump must always be installed and operated in a horizontal position i.e. with the outlet port facing vertically upwards. The fixing holes in the base should be used to secure the pump firmly in its operating position. Mount the pump on raised blocks or a purpose built platform to protect it from flooding. Some kind of anti-vibration mounting is also desirable.

Always ensure there is adequate air circulation around the motor. The pump should be installed in a dry, well ventilated enclosure, sheltered from rain, such as a purpose built pump room.

The pump is usually installed between the pool skimmer and the pool filter and should be positioned as near to the pool water level as possible. In other applications, a suction strainer should be used to protect the pump from ingress of foreign matter.

ELECTRICAL CONNECTION

The pump should be located at a safe distance, (usually 2 metres), away from the pool, and the power supply should be at least 3.5 metres from the pool. If in doubt, please contact your electrical specialist and refer to the International Electrical Commission (IEC) standard, (Electrical Installations for Buildings-part 7), referring to 'swimming pools and other basins'.

Avoid situations where the pump could become drenched with water as neither the motor or terminal box are designed to be waterproof. Ensure the pump & its cable do not create a safety hazard for people walking past it.

PIPE/HOSE CONNECTIONS

The pump inlet will be connected to any pool skimmer and/or pool drain connection, depending upon the installation layout, and the discharge outlet should be connected to your water filter.

The diameter of the inlet/outlet connectors is 40 mm. Therefore hoses with the same nominal diameter should be used and secured with a worm drive clip. Ensure all connections are air tight. Tighten them enough to secure the hose during pressurised operation, but not so tight as to crack the plastic inlet/outlet connectors.

Where the pump is to be a permanent fixture, vibration and strain on adjacent parts can be reduced by the insertion of a short flexible section of hose between any rigid pipework and the immediate area of the pump.

Any air leaks in the suction line will inhibit priming and reduce the capacity of the pump. Ensure there are no kinks in any flexible hose used.

The performance of your pump will be affected by the diameter of the inlet pipe - any restriction will greatly reduce the flow. We recommend that you always use a pipe diameter at least equal to, or greater than the diameter of the pump connections.

To prevent unnecessary strain or possible distortion to the pump, ensure that adequate support is provided to the hoses and or pipes. They will be considerably heavier when filled with water.

It is suggested that suction and delivery isolation valves are fitted in order to isolate the pump. A gate valve may be installed in-line on the delivery side (outlet port) of the pump which can be adjusted as required to regulate the flow of water and can assist in priming the pump.

Protect the pump and pipework from freezing with the addition of suitable lagging. The formation of ice may cause serious damage.

SUCTION LIFT OR GRAVITY FEED

The schematic diagrams, figs. 2 and 3, illustrate possible methods of pipework installation. This pump is designed primarily to be gravity fed, that is, drawing water from an above ground pool. However, it is possible to draw water from a sunken pool, providing the suction lift does not exceed the distance specified for your pump. The suction lift i.e. the vertical distance between the water level and the pump should not exceed 7 metres.

A foot valve/filter must be fitted to the lower end of the suction hose, (as illustrated in fig 2), so as to help retain water in the suction system. Remember.... this is NOT a self priming pump.

When suction lift is used to draw water into the pump it is essential that all connections and hoses are completely air tight, otherwise the system will not work.

Before pumping it is essential to completely fill the suction side with water. This is known as priming the pump and is carried out as follows:-

1. With the pump, all inlet pipes/hoses and the foot valve in position, slowly pour water into the outlet port. Wait until all air is expelled...this may take a minute or two...and fill to the brim before connecting the outlet hose to the outlet port. The hose is then connected to the water filter.
2. Switch on the pump. Water should start to flow through the system. Check for leaks and repair as necessary.

Do not allow the pump to run dry, otherwise the seal between the pump and motor may be damaged. If a leak is noticed at this point it may indicate that the seal is worn and therefore in need of replacement. Contact your CLARKE dealer, or the Clarke International Service Department for advice.

Do not place any restriction on the inlet side of the pump.

Remember - this pump is designed for pumping CLEAN WATER with small solids in suspension, ONLY. DO NOT USE for pumping chemicals or other corrosive liquids (other than pool purification chemicals in their correct mix ratio).

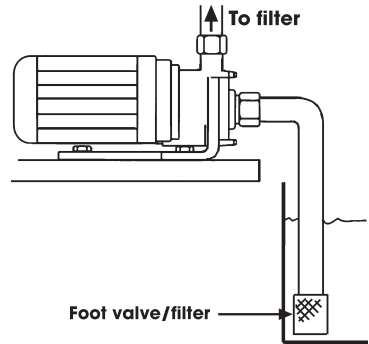

Fig 2:-Suction Lift

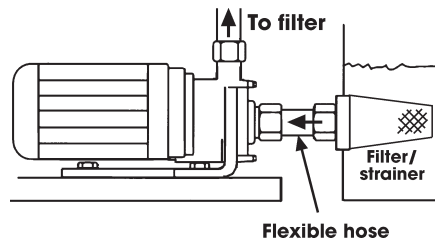

FIG 3:- Gravity Feed

OPERATION

1. Open any valves in the pipeline.
2. If operating the pump for the first time, disconnect the top hose and prime the pump by filling completely with water.

Note: The pump is only self-priming when filled with water. Refilling is only necessary if the pump has been drained, or if all the water has been lost.

3. Connect to the power supply and switch on. Water should start to flow through the system. Check for any leaks and repair as necessary.
4. If the motor fails to start, or the pump does not deliver water, refer to TROUBLESHOOTING on page 9. Never operate the pump when not filled with water or if the inlet is blocked.

Note: Filling the suction pipe with water will speed up the priming process, and it is suggested that a non-return valve be fitted to the end of the suction pipe.

5. Stop the pump by switching off the power supply.

SETTING THE TIMER

The programmable timer provides operation for 2 to 24 hour periods in 2 hour increments up to 16 hours. When the pump is connected to the power supply one LED will always be on. A backup battery is provided to save the settings in case the electrical power supply is disconnected. If power is lost, the pump will start automatically as soon as power is restored.

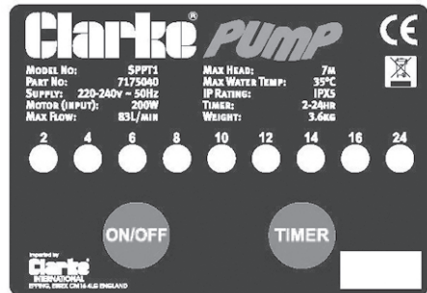

The duration of the cycle remaining can be seen by the status of the LEDs.

For example, to set the pump for 6 hours running in a 24 hour period:

1. Press the timer until the "6" LED turns red.
2. Press the ON/OFF button and the 6 hour running period will start.
3. Switch the pump off by pressing the ON/OFF button.

CARE DURING USE

1. Do not allow the pump to run dry, otherwise the seal between the pump and motor may be damaged. If a leak is noticed at this point, it may indicate that the seal is worn and therefore in need of replacement. Contact your CLARKE dealer, or the Clarke International Service Department for advice.
2. In the event of a blockage, where debris has entered the suction chamber, it can be cleaned out as described under MAINTENANCE.
3. Should contaminants come into contact with the pump, flush through with cold water as soon as possible to prevent damage to the pump. DO NOT USE for pumping chemicals or other corrosive liquids (other than pool purification chemicals in their correct mix ratio).
4. If the pump is being used to drain the pool, ensure there is adequate drainage and there is no risk of damage to property as a result of water being discharged. If a flexible hose must be laid across a roadway, protect it with wooden planking.

MAINTENANCE

The only maintenance required is a regular inspection to ensure that debris is not blocking the passage of water through the pump.

If you suspect the pump is blocked by silt, leaf debris etc, disconnect it from the mains supply and back-flush to clear any blockage using a hose. You will need to disconnect the outlet hose to do this.

Always keep the pump in a clean condition, checking regularly for loose bolts or a damaged power cable etc.

The pump should not be taken apart by the user in the case of overhaul being required, but should be taken to your nearest Clarke dealer for specialist repair.

AFTER USE

After use, and if the pump will not be used over the winter period, or whenever there is danger of freezing, always drain the pump body. If the pump has been used with contaminated or salty water, it should be thoroughly flushed with clean water following use, both inside and out. It should then be drained and covered over, if not already installed in a clean, dry environment sheltered from the weather.

Remember to re-prime the pump when returning to service.

In the event that dismantling and overhaul of the pump is necessary, contact your CLARKE International Service Department on 020-8988-7400.

THE TIMER BATTERY

The timer is equipped with a re-chargable battery which should re-charge when the pump is running. Tamper-proof screws are used to secure the top cover requiring a Y-type screwdriver. If one is not available and the battery has failed, take the pump to your Clarke dealer.

ENVIRONMENTAL PROTECTION



Any redundant accessories and packaging should be sorted and taken to a recycling centre to be disposed of appropriately.

Through the purchase of this product, the customer is taking on the obligation to deal with the WEEE in accordance with the WEEE regulations in relation to the treatment, recycling & recovery and environmentally sound disposal of the WEEE.

In effect, this means that this product must not be disposed of with general household waste. It must be disposed of according to the laws governing Waste Electrical and Electronic Equipment (WEEE) at a recognised disposal facility.

TECHNICAL DATA

Dimensions (L x W x H):	307 x 142 x 220 mm
Weight:	3.6 kg (8 Lb)
Inlet/Outlet Size:	40 mm
Max Flow:	83 L/min
Max Head:	7 m
Max Water Temperature:	35°C
Suitable Water Type:	Swimming pools/clean water
Power Supply:	220-240V @50 Hz
Sound Pressure Level:	68.6 dB LpA
Sound Power Level:	69.3 dB LwA
Guaranteed Sound Power:	73 dB LwA
Timer Run Times:	2 hour increments - 24 hours
Power Cable Length:	1.8 m

Please note that the details and specifications contained herein, are correct at the time of going to print. However, CLARKE International reserve the right to change specifications at any time without prior notice.

TROUBLESHOOTING

PROBLEM	CAUSE	SOLUTION
Pump does not run.	No mains supply	Check fused power supply and replace fuse if necessary (check fuse rating). Check circuit breaker.
	Impeller seized/blocked.	Disconnect pump from mains supply. Investigate cause and clear blockage.
Pump fails to prime.	Air leaks through suction hose joints (damaged hose, broken clamp, damaged/ill-fitting gasket)	Repair connections/replace hose as necessary.
	Blocked inlet hose.	Check pipeline and pool skimmer for blockage. Check any inlet valve fitted is fully open.
Pump runs but gives poor output.	Congested material inside pump.	Clean out & backflush pump.
	Suction or delivery line obstructed.	Remove obstruction and ensure there are no kinks in delivery line.
	Inlet pipe leakage.	Check inlet pipe and connector for leaks. Tighten as required.
	Air leaks through damaged seal.	Renew seal.
	Impeller damaged and making poor seal.	Return to your CLARKE dealer for repair.
	Impeller / mechanical seal is badly worn.	Return to your CLARKE dealer for repair.
	High friction losses in the suction line.	Avoid unnecessary curves, restrictions or valves.
	Pump badly sited resulting in suction lift too high.	Set pump as close as possible to the level of the water to be pumped.
Sudden loss of flow.	Blockage of inlet pipe.	Check pipeline and pool skimmer for blockage.

TROUBLESHOOTING

PROBLEM	CAUSE	SOLUTION
Undue vibration or noise.	Excessive flow of water.	Decrease flow of water, by adjusting inlet/outlet valves in system.
	Resistance in inlet pipe caused by obstruction.	Check pipe and clean out as necessary.
	Loose rotating component	Return to your dealer for repairs.
	Installation of pump is unstable.	Stop pump and re-position.
	Air pocket in pump or pipeline.	Release drain plug in impeller housing to release air.
	Damaged impeller	Return to your CLARKE dealer for repair.

SPPT1 PERFORMANCE

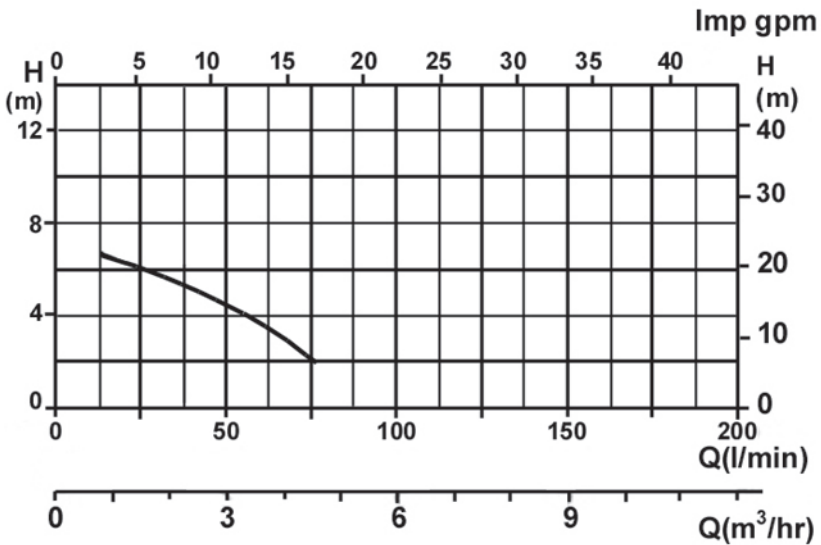

PARTS LIST

No	Description	Qty	No	Description	Qty
1	Socket Headed Bolt	6	23	Screw	1
2	Impeller Housing	1	24	Star Washer	1
3	Nut	1	25	Self-tapping Screw	6
4	Flat Washer	1	26	Main Seal	1
5	Washer	1	27	Ball Race	1
6	Impeller	1	28	Key	1
7	O-ring Seal	1	29	Armature	1
8	Mounting Frame	1	30	Circlip	1
9	Water Seal	1	31	Ball Race	2
10	Motor Cover	1	32	Tamper-proof Screw	4
11	Socket Headed Bolt	4	33	Control Box Cover	1
12	Motor Stator Assembly	1	34	Plastic Washer	1
13	Socket Headed Stud Bolt	3	35	Gland Sealing Nut	1
14	Wave Washer	1	36	Power Cable	1
15	Rear Cover	1	37	Sealing Gland	1
16	Flat Washer	3	38	Fan	1
17	Spring Washer	3	39	Fan Cover	1
18	Terminal Block	1	40	Printed Circuit Board	1
19	Brass Washer	1	41	Mounting Base	1
20	Brass Nut	1	42	Control Box Body	1
21	Capacitor	1	43	Rear Mounting Screw	1
22	Gasket	1	44	Front Mounting Screw	1

ACCESSORIES

A wide range of accessories is available, including foot valve filters, suction and layflat hoses and clips, couplings and 90° hose adaptors, etc.

Contact your Clarke dealer for further information. The use of parts other than genuine Clarke replacement parts may result in possible safety hazards or decreased pump performance and will invalidate your warranty.

PARTS DIAGRAM

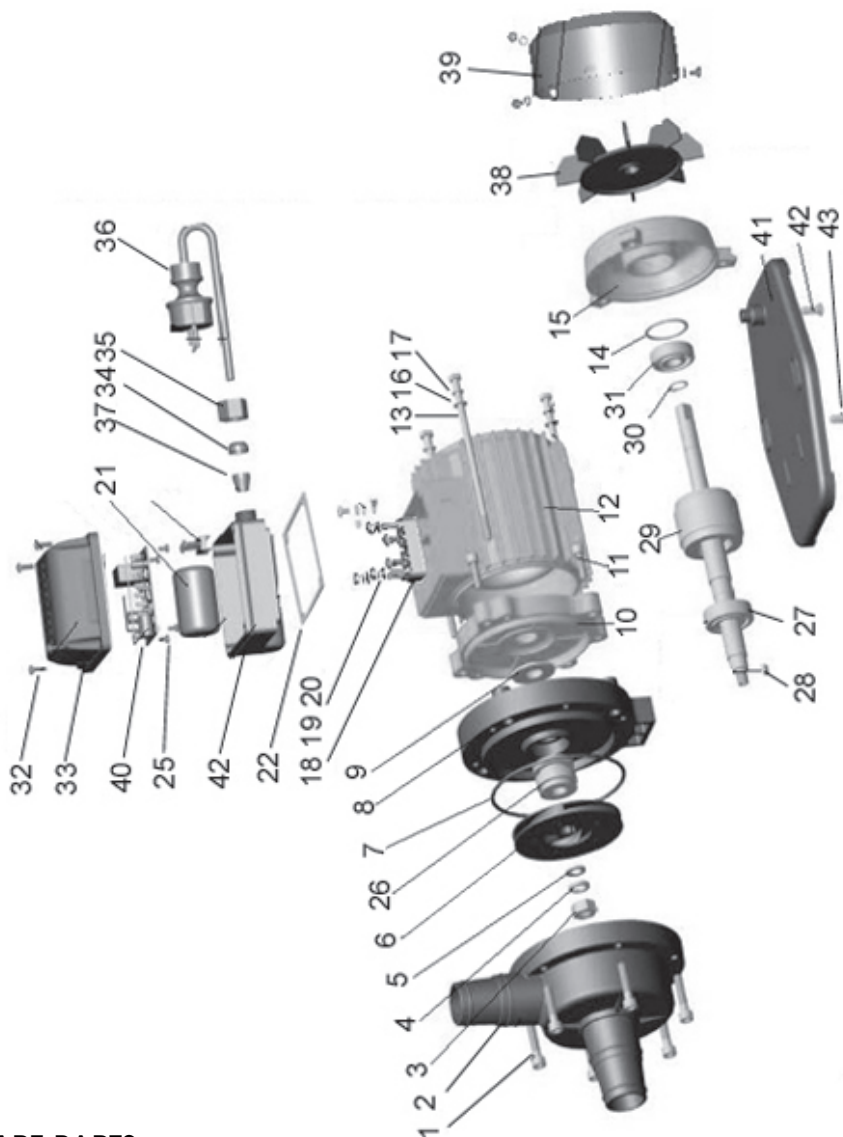

SPARE PARTS

When requesting spare/replacement parts for these pumps from CLARKE Parts & Service, please quote the prefix 'ZG' followed by the model number (SPPT1) and the item number from the parts list/diagram.

Clarke

DECLARATION OF CONFORMITY



DECLARATION OF CONFORMITY

This is an important document and should be retained.

Product Description: 200 W Swimming Pool Pump with Timer
Model number(s): SPPT1
Serial / batch Number: N/A
Date of Issue: 09/04/2012
(Noise Conformity)
Notified Body: TÜV SÜD Industrie Service GmbH
Westendstraße 199
80666 München
Germany

Technical Documentation Holder:

A.R. Pond
Clarke International
2a Shrubland Road
London E10 7RB
UK

Conformity Assessment Procedure:

to 20001/4/IEC Annex VI
Manufacturer: Clarke International
Noise Related Value: 155 W
Measured Sound Power Level: 69dB
Guaranteed Sound Power Level: 73 dB

10-0624 pool pump D.O.C (v1)

Page 1 of 2



DECLARATION OF CONFORMITY

This is an important document and should be retained.

We hereby declare that this product(s) complies with the following directive(s):
2004/109/EC *Electromagnetic Compatibility Directive.*
2006/95/EC *Low Voltage Equipment Directive.*
2002/95/EC *Restriction of Hazardous substances.*
2000/14/EC *Noise Emissions Directive, (amended by 2005/69/EC).*

The following standards have been applied to the product(s):

EN 60335-1:2002+A11+A12+A2+A13, EN 60335-2-41:2003+A1, EN 62233:2008
EN 55014-1:2006, EN 55014-2:1997+A1:2001, EN 61000-3-2:2006, EN 61000-3-3/A1:2001+A2:2005.
The technical documentation required to demonstrate that the product(s) meet(s) the requirement(s) of the aforementioned directive(s) has been compiled and is available for inspection by the relevant enforcement authorities.

The CE mark was first applied in: 2012

Signed:

J.A. Clarke
Director

10-0624 pool pump D.O.C (v1)

Page 2 of 2

A SELECTION FROM THE VAST RANGE OF

Clarke®

QUALITY PRODUCTS

AIR COMPRESSORS

From DIY to industrial, Plus air tools, spray guns and accessories.

GENERATORS

Prime duty or emergency standby for business, home and leisure.

POWER WASHERS

Hot and cold, electric and engine driven - we have what you need

WELDERS

Mig, Arc, Tig and Spot. From DIY to auto/industrial.

METALWORKING

Drills, grinders and saws for DIY and professional use.

WOODWORKING

Saws, sanders, lathes, mortisers and dust extraction.

HYDRAULICS

Cranes, body repair kits, transmission jacks for all types of workshop use.

WATER PUMPS

Submersible, electric and engine driven for DIY, agriculture and industry.

POWER TOOLS

Angle grinders, cordless drill sets, saws and sanders.

STARTERS/CHARGERS

All sizes for car and commercial use.



PARTS & SERVICE: 020 8988 7400

E-mail: Parts@clarkeinternational.com or Service@clarkeinternational.com

SALES: UK 01992 565333 or Export 00 44 (0)1992 565335

Clarke INTERNATIONAL Hemnall Street, Epping, Essex CM16 4LG
www.clarkeinternational.com