

CLAMPBRO®



30KW ELECTRIC FAN HEATER

MODEL NO: DEVIL 7030

PART NO: 6935458

OPERATION & MAINTENANCE INSTRUCTIONS



LS0717 - ISS 2

INTRODUCTION

Thank you for purchasing this CLARKE product.

Before attempting to use this product, please read this manual thoroughly and follow the instructions carefully. In doing so you will ensure the safety of yourself and that of others around you, and you can look forward to your purchase giving you long and satisfactory service.

GUARANTEE

This product is guaranteed against faulty manufacture for a period of 12 months from the date of purchase. Please keep your receipt which will be required as proof of purchase.

This guarantee is invalid if the product is found to have been abused or tampered with in any way, or not used for the purpose for which it was intended.

Faulty goods should be returned to their place of purchase, no product can be returned to us without prior permission.

This guarantee does not effect your statutory rights.

LIST OF CONTENTS

1 x Heater	1 x Axle c/w Circlips (2)
1 x R/H & 1 x L/H Support Frames	2 x Wheel
1 x Upper Handle	1 x Fixings Pack

ENVIRONMENTAL RECYCLING POLICY



Through purchase of this product, the customer is taking on the obligation to deal with the WEEE in accordance with the WEEE regulations in relation to the treatment, recycling & recovery and environmentally sound disposal of the WEEE.

In effect, this means that this product must not be disposed of with general household waste. It must be disposed of according to the laws governing Waste Electrical and Electronic Equipment (WEEE) at a recognised disposal facility.

SAFETY SYMBOLS

The following symbols appear on the unit.

	Hot Surface, Do Not Touch		Do Not Cover		High Voltage
		DO NOT COVER			

SAFETY RULES

Make sure that you read, understand and comply with the following.

ELECTRICAL SAFETY



WARNING: THIS HEATER MUST BE FITTED WITH A SUITABLE CABLE AND PLUG (NOT SUPPLIED). THESE MUST BE FITTED AND THE HEATER MUST BE CONNECTED TO A 3-PHASE SUPPLY BY A QUALIFIED ELECTRICIAN (SEE PAGE 6).

WARNING: THIS HEATER MUST BE EARTHED

- Regularly inspect the power cable / plugs and all electrical connections for signs of damage/looseness. Do not use the heater if the power cable is damaged.
- Minimise the risk of electric shock by installing a RCCB (Residual Current Circuit Breaker) and a suitable 3-phase isolator into the main distribution board.
- Make sure that the voltage on the rating plate is the same as the voltage of the power supply. If in doubt, consult a qualified electrician.
- Do not abuse the electrical cable. Never use the cable for pulling or unplugging the heater.
- Keep the cable away from sources of heat, oil, sharp edges or moving parts. Damaged or tangled cables increase the risk of electric shock.
- Do not use extension cables with this heater.

MAINTENANCE.



WARNING: DISCONNECT THE HEATER FROM THE POWER SUPPLY, BEFORE SERVICING OR PERFORMING ANY MAINTENANCE. SERVICING OR MAINTENANCE MUST ONLY BE CARRIED OUT BY THE CLARKE SERVICE DEPARTMENT.

- Check that the heater is in good working order. Take immediate action to repair or replace damaged parts.
- Do not allow the heating elements to become covered with dust which could become a fire hazard. If used in a dusty workplace it should be cleaned as described under Cleaning and Maintenance.
- Use recommended parts only. Unapproved parts may be dangerous and will invalidate the warranty.
- DO NOT attempt to repair a damaged heater, contact the Clarke service department.

POSITIONING



WARNING: DO NOT USE THE HEATER NEAR FLAMMABLE MATERIAL, LIQUIDS, SOLIDS, GASES OR COMPRESSED GAS CYLINDERS ETC.

- Heater is designed for indoor use only. DO NOT place the heater close to a bath, wash basin, shower, swimming pool or any other water-filled area or wet surface. DO NOT place the heater up against any surface such as a wall, door or furniture etc.
- DO NOT place the heater immediately below any electrical outlet.
- NEVER place the heater near combustible materials such as curtains, furniture etc. Allow at least 2 metre clearance.
- DO NOT place the heater on a raised surface or anywhere where it could topple over
- Take care to ensure that the grille cannot be blocked by curtains or other fabrics.
- Do not operate fan heaters in explosive atmospheres such as in the presence of flammable liquids, gases or dust such as in a paint spray booth or any explosive environment. Electric motors create sparks which may ignite dust or fumes.

COMMON SENSE

- DO NOT operate the heater when you are tired or under the influence of alcohol, drugs or intoxicating medication.
- DO NOT stand on the heater.
- DO NOT use the heater with wet hands or when there is water on the power cable.
- Turn the heater off when not in use and keep it in a safe, dry, childproof location.
- The heater is designed to heat enclosed areas larger than 4m³, such as workshops and other industrial areas. Do not use the heater for any other function. It is not suitable for drying clothes or laundry.
- Young children must be kept away unless continuously supervised.

OPERATION

- The heater must only be used by people who have read these instructions and have been trained in its use.
- DO NOT obstruct the air inlet and outlet sections of the heater.
- DO NOT cover the heater.
- DO NOT touch the heater casing or grille when first switched off, as these will be very hot and will take time to cool.
- DO NOT get the heater wet or use in areas of high condensation.
- DO NOT allow the power lead to touch hot surfaces.
- DO NOT connect other appliances to the same mains socket as the heater.
- Only use the heater in an level position.
- Do not use this heater with a programmable timer used to switch it on automatically.

SERVICE & REPAIRS

- Have your appliance repaired by a qualified person using identical replacement parts. This will ensure that the safety of the appliance is maintained.

ELECTRICAL CONNECTIONS



WARNING: THE INSTALLATION OF THIS APPLIANCE SHOULD BE CARRIED OUT BY A COMPETENT ELECTRICIAN AND BE IN ACCORDANCE WITH THE CURRENT IEE WIRING REGULATIONS (BS7671-2:2008).

This machine **MUST** be connected to a 400 Volt, 3 phase 50Hz supply through a suitably rated isolator switch. It cannot be operated from a single phase supply.

The user should purchase a suitable connecting cable capable of handling 63 Amps (recommended Cross Sectional Area 10mm²) and supply plug rated at 63A (or better) which complies with BSEN 60309. A length of 2-3 metres is recommended giving mobility to the appliance but without becoming a trip hazard

If in any doubt, consult a qualified electrician. **DO NOT** attempt any electrical work yourself.

SAFETY SYSTEMS

THERMOSTATIC PROTECTION

The Devil 7030 has a thermal cut out to prevent the unit from overheating.

If the temperature of the front grille gets too high the thermal cutout will turn off the heating elements. When the fan has cooled the unit sufficiently, normal operation will resume.

ASSEMBLY

1. Fit the right leg frame to the main body as shown.

NOTE: The bolt needs to be inserted before the handwheel.

NOTE: The bolt goes through the larger of the 2 holes in the spacer.

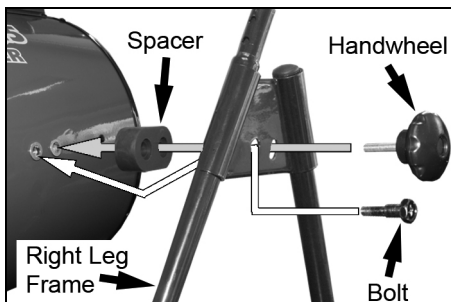

2. Fit the axle and left hand support frame.

NOTE: The circlip shown must be on the inside of the legs.

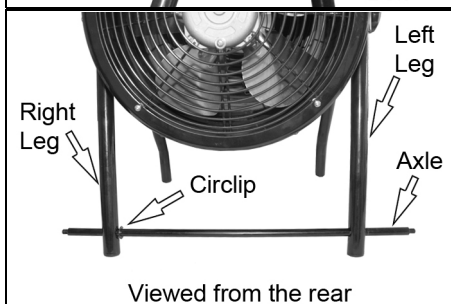

3. Fit the wheels as shown.

NOTE: The cap fits over the flat washer.

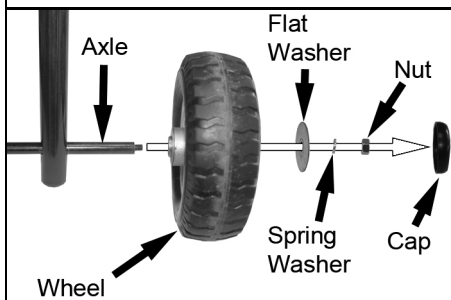

4. Use the nuts and bolts supplied, to secure the handle to the leg frames as shown.

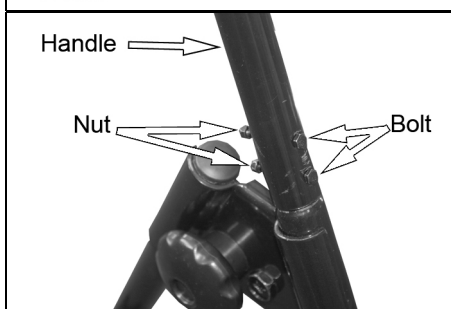

OPERATION



WARNING: DO NOT USE THIS HEATER IN SMALL ROOMS WHEN THEY ARE OCCUPIED BY PERSONS NOT CAPABLE OF LEAVING THE ROOM ON THEIR OWN, UNLESS CONSTANT SUPERVISION IS PROVIDED.



CAUTION: SOME PARTS OF THIS PRODUCT CAN BECOME VERY HOT AND CAUSE BURNS. PARTICULAR ATTENTION HAS TO BE GIVEN WHERE CHILDREN AND VULNERABLE PEOPLE ARE PRESENT.

1. Put the heater in a level position on a flat surface and at a safe distance from flammable materials. Keep a minimum of 2m clearance all round.
2. Connect the heater to a suitable power supply.
3. Set the thermostat control to the maximum setting (fully clockwise).

4. Set the mode selector to one of the 3 settings:

0	Off
	Fan Only
	Fan + Heat Setting 1
	Fan + Heat Setting 2

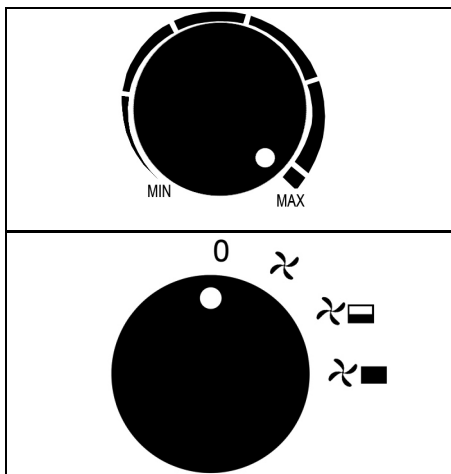

- The heater will take up to three minutes to reach optimum temperature.
5. Once the room reaches the required temperature, turn the thermostat control slowly counter-clockwise until the thermostat clicks, leave the control in this position.
 - The room temperature will be maintained at this setting. The heater will continue to operate until the power switch is turned to the OFF position.

6. For fan only operation, turn the power switch to the fan only setting and set the thermostat to its minimum setting.
7. Turn the heater off by turning the power switch to "0",
 - Do not remove the plug from the mains supply. The fan will continue to run for several minutes to lower the temperature of the case and elements. Once the fan stops you can safely remove the plug from the power supply.
8. When not in use, disconnect the heater from the mains supply. Store it in a safe, dry, childproof location.

MAINTENANCE



WARNING: ALWAYS DISCONNECT FROM THE POWER SUPPLY AND ALLOW THE HEATER IT TO COOL DOWN BEFORE PERFORMING ANY MAINTENANCE TASKS.

- Clean the heater with a soft damp cloth, Do not use solvents or abrasives.
- Make sure that the heater grill is not blocked.
- No other maintenance is required, should you discover any problem with the heater, return it to the Clarke service department for repair.

SPECIFICATIONS

Operating Voltage, Current and Frequency: (V / A / Hz / Phs)	400 V / 43A / 50Hz / 3 Phase
Operating Temperature: (Min/Max) (°C)	0-40°C
Heat Output: (kW)	30 kW
Air Output: (m ³ /h)	1440m ³ /h
Safety Device	Thermal cut-out
Duty Cycle Classification	Continuous duty
Electrical Insulation Class	I
Product: Depth x Width x Height	640 x 610 x 1012 mm
Product Weight	30.45 kg

TROUBLE SHOOTING

Problem	Possible Cause	Remedy
Heater does not operate, although plugged in with the switch and thermostat switched on.	Plug is loose/bad connection.	Pull the plug out & check all connections (cable/plug and socket).
	Fuse blown or circuit breaker trips.	Replace if necessary and investigate cause. If fuse blows repeatedly, consult your Clarke dealer.
	No power at socket outlet.	Insert the plug in a suitable socket.
Heating element glowing hot.	Input voltage too high or too low.	Use a power supply in accordance with the rating on the label.
	Air inlet grille is blocked.	Ensure the heater is kept away from any objects which could cover the air inlet or be drawn into it.
The unit has failed to heat up so only the air fan has operated.	Control switch not set at a "HEATING" level.	Turn switch to a heating level.
	Thermostat has tripped.	Turn the thermostat and listen. If there is no CLICK and the thermostat is not damaged, the heater will automatically switch ON when it has cooled down.
Abnormal noise.	Heater is not level.	Stand heater on a level surface.

PARTS DIAGRAM

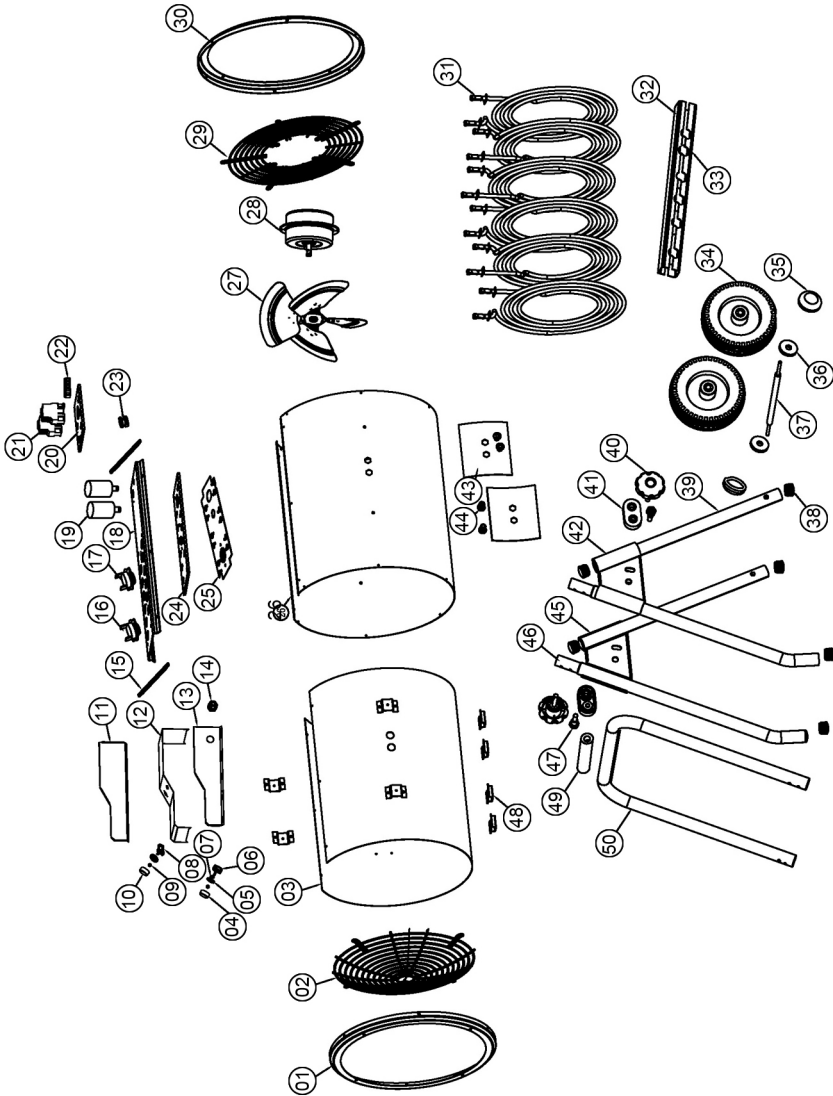

PARTS LIST

1	Front Rings	26	House Casing
2	Front Grille	27	Fan
3	Heat Shield	28	Motor
4	Switch Knob	29	Rear Grille
5	Securing Rings	30	Rear Rings
6	Speed Controller	31	Heating Elements
7	Location Part For Switch	32	Heater Bracket Upper
8	Temperature Controller	33	Heater Bracket Bottom
9	Fasten Spring	34	Wheel
10	Thermostat Knob	35	Wheel Cover
11	Control Box L	36	Securing Plate
12	Control Box Cover	37	Axle
13	Control Box R	38	Base Pad
14	Cable Inlet Gland	39	Rear Frame
15	Sealing Tape	40	Adjustable Screw
16	Overheat Thermostate	41	Spacer
17	After Cooling Thermostate	42	Securing Plate L
18	Chassis Panel	43	Securing Plate
19	Motor Capacitor.	44	Rivet Nut
20	Insulate Board Of Contactor	45	Securing Plate R
21	Ac Contactor	46	Front Frame
22	Wire Terminal	47	Fixing Bolt
23	Grommet	48	Location Plate
24	Insulate Board	49	Insulate Sleeve
25	Heat Shield	50	Upper Frame

Part number = (CXDEV7030 + the number of the part)

DECLARATION OF CONFORMITY



Clarke[®]
INTERNATIONAL

Hemnal Street, Epping, Essex CM16 4LG

DECLARATION OF CONFORMITY

This is an important document and should be retained.

We hereby declare that this product(s) complies with the following directive(s):

2014/30/EU *Electromagnetic Compatibility Directive.*
2014/35/EU *Low Voltage Equipment Directive.*
2011/65/EU *Restriction of Hazardous substances.*

The following standards have been applied to the product(s):

EN 60335-2-30:2009 +A11:2012, EN 60335-1:2012, EN 62233:2008, EN 61000-3-11:2000,
EN 55014-1:2006 +A1:2009 +A2:2011, EN 55014-2:2015, EN 61000-3-2:2014
EN 61000-3-3:2013, EN 61000-3-11:2000, EN 61000-3-12:2011

The technical documentation required to demonstrate that the product(s) meet(s) the requirement(s) of the aforementioned directive(s) has been compiled and is available for inspection by the relevant enforcement authorities.

The CE mark was first applied in: 2014

Product Description: Electric heater(s): 5 kW, 9 kW, 15kW, 22 kW, 30 kW
Model number(s): Devil 7005, Devil 7009, Devil 7015, Devil 7025, Devil 7030
Serial / batch Number: N/A
Date of Issue: 25/05/2017

Signed:

J.A. Clarke
Director

NOTES

A SELECTION FROM THE VAST RANGE OF

Clarke®

QUALITY PRODUCTS

AIR COMPRESSORS

From DIY to industrial, Plus air tools, spray guns and accessories.

GENERATORS

Prime duty or emergency standby for business, home and leisure.

POWER WASHERS

Hot and cold, electric and engine driven - we have what you need

WELDERS

Mig, Arc, Tig and Spot. From DIY to auto/industrial.

METALWORKING

Drills, grinders and saws for DIY and professional use.

WOODWORKING

Saws, sanders, lathes, mortisers and dust extraction.

HYDRAULICS

Cranes, body repair kits, transmission jacks for all types of workshop use.

WATER PUMPS

Submersible, electric and engine driven for DIY, agriculture and industry.

POWERTOOLS

Angle grinders, cordless drill sets, saws and sanders.

STARTERS/CHARGERS

All sizes for car and commercial use.



PARTS & SERVICE: 0208 988 7400

E-mail: Parts@clarkeinternational.com or Service@clarkeinternational.com

SALES: UK 01992 565333 or Export 00 44 (0)1992 565335

Clarke® INTERNATIONAL Hemnall Street, Epping, Essex CM16 4LG
www.clarkeinternational.com