

# Clarke®

## CONTRACTOR®



## SUBMERSIBLE WATER PUMP

MODEL NO: CSV1A, CSV2A

PART NO: 7230582, 7230602

## OPERATION & MAINTENANCE INSTRUCTIONS



---

## INTRODUCTION

---

- Thank you for purchasing this CLARKE Submersible Water Pump.
- This pump is designed for pumping dirty water only, that is water containing solids in suspension. **It is NOT designed for pumping slurry, sludge, mud or heavily polluted water, or any water containing chemicals or other acidic contaminants including salt water.**
- These pumps have the ability to pump solids as large as 30mm, however, the outlet elbow and delivery pipe diameter will restrict this.

---

## GUARANTEE

---

This product is guaranteed against faulty manufacture for a period of 12 months from the date of purchase. Please keep your receipt which will be required as proof of purchase.

This guarantee is invalid if the product is found to have been abused or tampered with in any way, or not used for the purpose for which it was intended.

Faulty goods should be returned to their place of purchase, no product can be returned to us without prior permission.

This guarantee does not effect your statutory rights.

---

## SPECIFICATIONS

---

	CSV1A	CSV2A
Outlet Diameter	1½"/38mm	1½"/38mm
Motor Output (Watts)	330	620
Head Max (m)	5	8
Max. Capacity (L/min)	118	200
Weight	3.7	5.2
Cable (m x mm <sup>2</sup> )	10 x 1.5	10 x 1.5
Dimensions (mm) not including the elbow	140 x 300	140 x 300

## SAFETY PRECAUTIONS

1. These pumps are designed to pump WATER ONLY. Never use for pumping flammable liquids or chemicals.
2. Never run the pump dry.
3. An approved Residual Current Device (RCD) which has a tripping current of less than 30mA must be used when pumping from ponds or swimming pools.
4. Never carry the pump by the mains lead or float switch.
5. Never pull the mains lead to disconnect the pump from the mains socket.
6. Your submersible pump may only be used for pumping water from a swimming pool when there is no person or animal in the pool.
7. Always disconnect the pump from the electrical supply before placing it into, or removing it from the water, and before any cleaning or maintenance of the pump.
8. Always use the moulded handle (or lifting eye), with a rope or cord attached when lifting the pump. NEVER lift the pump by the mains cable, or, where fitted, the float switch cable.
9. DO NOT run the pump with the body exposed for longer than 10 minutes.
10. DO NOT install the pump on sand, or ground which is likely to shift.
11. Do not use the pump if the water is liable to freeze, as this can cause damage to the pump. Remove the pump from the water and store it in a frost free location.
12. If the pump is to be used where there may be silt or mud (for example, garden ponds), keep the pump clear of any sediment by standing it on a platform or brick.
13. Do not allow children to touch the pump, cables or connections.
14. Disconnect the pump from the mains supply when not in use.
15. Have the pump repaired by a qualified person.
16. Keep the mains lead away from heat, oil and sharp edges.
17. Always check the plug, mains cable and float switch cable for damage before use. Do not use the pump if damaged. Refer to qualified service personnel for repair.
18. If you have to use an extension lead with this product, it must be designed for outdoor use and incorporate a cable suitable for use with Class I appliances.

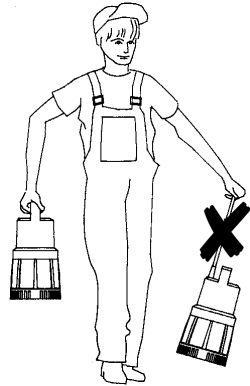

---

## ELECTRICAL CONNECTIONS

---

These models must be connected to a protected 110V supply, through a suitably approved connector. On no account must a 230V, 13amp (BS1363) plug be used.

**NOTE:** If a portable 110V transformer is used, make sure it has a rated capacity sufficient to take the load of the machine.

In the event that the heater is hard wired into the electrical system, it must be carried out in accordance with IEE regulations.

### CABLE EXTENSION

Always use an approved cable extension suitable for the power rating of this tool (see specifications), the conductor size should also be at least the same size as that on the machine, or larger. When using a cable reel, always unwind the cable completely.

#### IMPORTANT:

If you are in any doubt regarding electrical installation, you should consult a qualified electrician.

---

## PUMP PERFORMANCE DATA

---

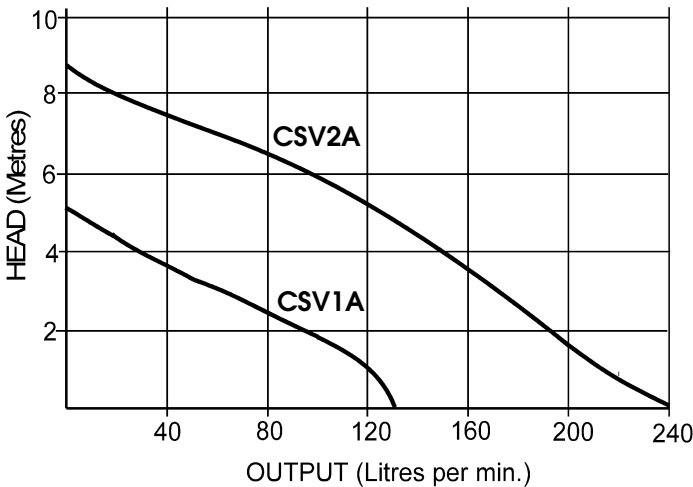

## PREPERATION

### CONNECTING THE MULTI HOSE ADAPTOR



**WARNING: DISCONNECT THE PUMP FROM THE MAINS POWER SUPPLY BEFORE CONNECTING THE MULTI HOSE ADAPTOR.**

1. Fit the elbow adaptor to the pump outlet as shown in the diagram opposite.
2. Screw the multi hose adaptor onto the elbow.
  - The multi hose adaptor is capable of accepting 1", 3/4" and 1/2" hoses.
3. Simply cut the multi hose connector to the required size and attach a suitable hose using with a worm drive clip.
  - For maximum efficiency, we strongly recommend that you connect a 1 1/2" diameter hose to the multi hose adapter.
  - Alternatively, you may remove the multi adapter altogether, and screw on a 1 1/2" BSP hose adapter.

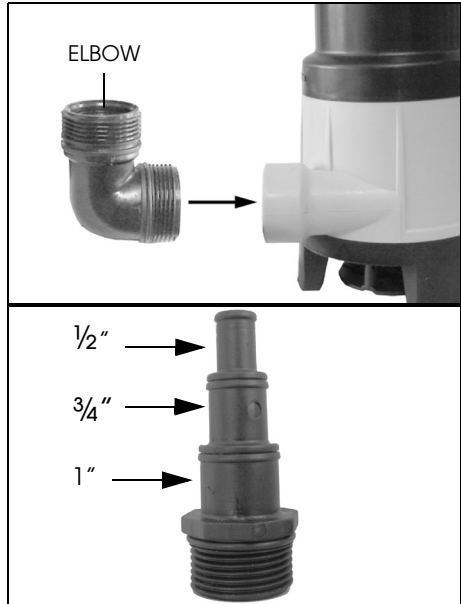

The pump is completely submersible, and should be placed in a vertical position, on a solid flat surface, placing the pump on a couple of house bricks if required.

**SUITABLE HOSES AND SPARE/REPLACEMENT MULTI HOSE ADAPTERS ARE AVAILABLE FROM YOUR CLARKE DEALER.**

---

## USING THE PUMP

---



CAUTION: CHECK THE PUMP FOR DAMAGE BEFORE USE, DO NOT USE THE PUMP IF IT IS DAMAGED IN ANY WAY.

---

1. Place the pump on a flat surface in the area that you want to drain.
    - If there is sediment in the operating area, the pump should be placed on house bricks, or similar.
    - Ensure the pump is positioned with adequate space so that the movement of the float switch is not restricted - recommended minimum area of 40 x 40cm.
    - ALWAYS raise and lower the pump using a rope attached to the lifting handle.
    - Take all necessary precautions as described on page 3 before plugging in, and switching ON.
- 



**WARNING: NEVER CARRY THE PUMP USING THE MAINS POWER CABLE. DAMAGE TO ELECTRICAL CABLES CAN BE HAZARDOUS . ALWAYS USE THE HANDLE WHEN MOVING THE PUMP.**

---

2. Connect the mains plug to a high sensitivity residual current device (RCD) which has a tripping current of less than 30mA.
  3. Switch the mains power supply on.
    - The pump incorporates a float switch, which automatically switches the pump ON when the water is above a pre-determined level.
  4. The pump will begin to drain water.
    - As the water level falls, so will the float switch, until it stops the pump.
  5. When the pumping is finished, disconnect the pump from the mains power supply.
    - These pumps are fitted with automatic thermal overload protection. If the pump overheats due to an obstruction in the pump, or pumping warm water for example, it will shut off automatically. Switch the pump OFF and disconnect from the mains supply. Check for blockages and allow the motor to cool (at least 5 minutes) before attempting to re-start.
- 



CAUTION: DO NOT ALLOW THE PUMP TO RUN DRY

---

---

# MAINTENANCE

---



**WARNING: BEFORE CHECKING THE CONDITION OF THE PUMP, ENSURE IT IS UNPLUGGED FROM THE MAINS SUPPLY. IF THE UNIT IS HARD WIRED, ENSURE THE CIRCUIT BREAKER IS OPEN.**

---

These pumps should require no maintenance other than regular cleaning. If the pump starts to show signs of wear or damage, contact your CLARKE dealer for advice.

- Do not use the pump if there is any damage to the mains supply cable, or to the float switch or its cable.
- Do not attempt to repair the pump yourself, as you may damage the waterproof seal and invalidate your guarantee. Repairs must be carried out by your CLARKE dealer, or contact the CLARKE Service Department, on 020 8988 7400.

## CLEANING

1. Check the pump installation regularly to ensure the base inlet is clear of leaves or other debris.

- These pumps have screwless fittings at their base, allowing the removal of the plastic cover by prising the two release clips apart in the direction of the arrows. This allows better access to the cavity at the bottom should the pump become badly clogged. Flush the cavity and the Impeller housing with clean water.
- To replace the cover, ensure the release clips line up with the holes on the base of the pump, and press the cover home.

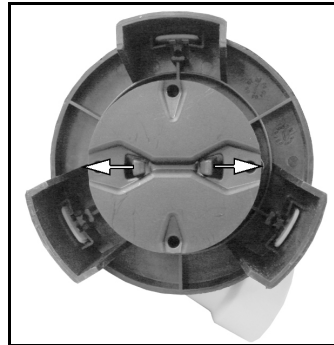

**NOTE:** Do not attempt to strip the pump further as this will invalidate the guarantee.

# TROUBLESHOOTING

	SOLUTION
PUMP WILL NOT START	<ol style="list-style-type: none"> <li>1. Check to ensure Power is switched on.</li> <li>2. Check fuse (consult an electrician if in doubt).</li> <li>3. If extension lead is fitted, check connections (consult an electrician if in doubt).</li> <li>4. Internal thermal cut-out has not re-set. Leave for 5 minutes and try again.</li> <li>5. The Impeller may be jammed. Disconnect from the mains supply, remove the bottom strainer, and remove any objects that may be obstructing the impeller. Replace the strainer and try again.</li> <li>6. If the pump still fails to start, consult your CLARKE dealer for advice.</li> <li>7. Float switch may be jammed against side wall, or prevented from moving.</li> <li>8. Water level too low - float switch in OFF position - lift float to check switch.</li> </ol>
PUMP WILL START BUT NOT PUMP	<ol style="list-style-type: none"> <li>1. Check to ensure strainer is not blocked.</li> <li>2. Discharge tube clogged or obstructed.</li> <li>3. The head may be too great, i.e. you are trying to lift the water too great a distance for the pump to cope with. (See specification chart page 4).</li> <li>4. Air bubble in the pump, produced during the plunge. Plunge the pump again, at an angle, and shake it whilst lowering to remove any air trapped in the system.</li> <li>5. Impeller may be damaged - Consult your CLARKE dealer.</li> </ol>
PUMP WILL NOT STOP	<ol style="list-style-type: none"> <li>1. Float switch may be prevented from moving to the fully down position.</li> <li>2. Float switch may be faulty. Consult your CLARKE dealer for advice.</li> </ol>
PUMP STOPS RUNNING	<ol style="list-style-type: none"> <li>1. Thermal overload has operated. If this condition persists, investigate the cause. Are you attempting to pump liquid which is too heavy for the pump (mud, slurry etc.)</li> <li>2. Pump has run dry, or float switch has cut in.</li> <li>3. A foreign object has jammed the impeller.</li> </ol>

If this does not solve your problem, please contact the clarke service department. See page 10.

# EXPLODED PARTS DIAGRAM

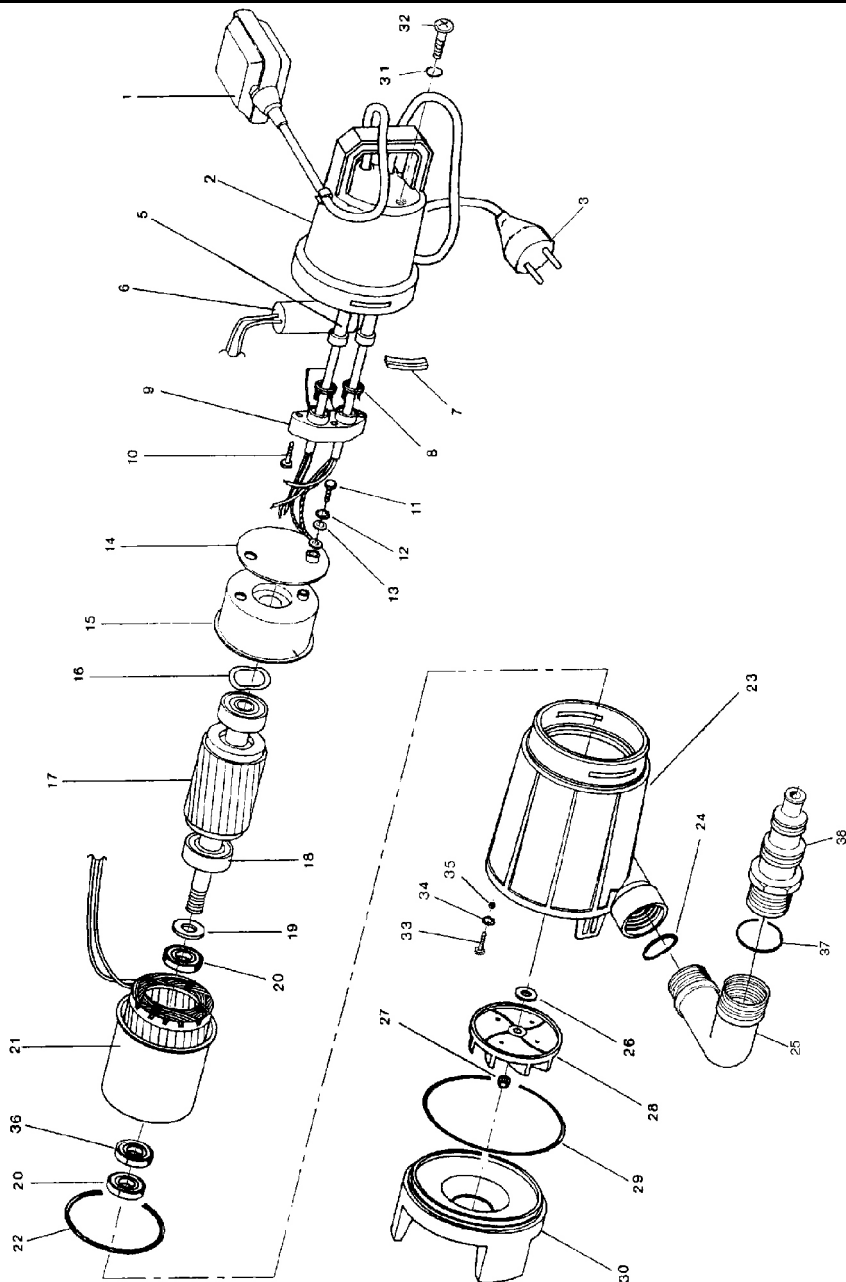

## PARTS LIST

	DESCRIPTION	PART NO	NO	DESCRIPTION	PART NO
1	Floatswitch	LDP1380002	21	Stator (CSV1A)	LDS3410004
2	Cap	LDS3600170	21	Stator (CSV2A)	LDS3410017
3	Cable 10m	LDP1320016	22	Joint O-Ring	LDP1200007
4	Grommet	N/A	23	Pump housing (CSV1A)	LDS3500206
5	Grommet	LDP1230003	23	Pump housing (CSV2A)	LDS3500207
6	Capacitor	LDP1360030	24	Joint O-Ring	LDP1200009
7	Lock	LDS3500011	25	Elbow with O-Ring	LDS3600111
8	Anti-tear ring	LDS3500336	26	Washer	LDP1120006
9	Cable fastener	LDS3500335	27	Nut	LDP1110005
10	Screw	LDP1100008	28	Impeller (CSV1A)	LDS3500013
11	Earth screw	LDP1100003	28	Impeller (CSV2A)	LDS3500014
12	Spring-washer	LDP1120003	29	Joint O-Ring	LDP1200008
13	Washer	LDP1120051	30	Pedestal	LDS3500018
14	Insulation disk	LDS3500106	31	Joint O-Ring	LDP1200033
15	Upper flange	LDS3120005	32	Screw	LDP1100090
16	Waved ring	LDP1120002	33	Screw	LDP1100014
17	Ceramic shaft with bearings (CSV1A)	LDS3101001	34	Washer	LDP1120017
17	Ceramic shaft with bearings (CSV2A)	LDS3101002	35	Sphere	LDP1180003
18	Bearing	LDP1180001	36	Twin lip seal	LDP1210004
19	Washer	LDP1120007	37	Joint O-Ring	LDP1200002
20	Lip seal	LDP1210001	38	Fitting 3 step with O-Ring	LDS3600162

## PARTS AND SERVICING

For Parts & Servicing, please contact your nearest dealer, or  
CLARKE International, on one of the following numbers.

**PARTS & SERVICE TEL: 020 8988 7400**

**PARTS & SERVICE FAX: 020 8558 3622**

**or e-mail as follows:**

**PARTS: [Parts@clarkeinternational.com](mailto:Parts@clarkeinternational.com)**

**SERVICE: [Service@clarkeinternational.com](mailto:Service@clarkeinternational.com)**

# DECLARATION OF CONFORMITY



## DECLARATION OF CONFORMITY

This is an important document and should be retained.



**We declare that this product complies with the following directives:**

- 97/23/EC      *Pressure Equipment Directive*
- 73/23/EEC    *Low Voltage Equipment directive ( amended by 93/68/EEC).*
- 89/336/EEC   *Electromagnetic Compatibility directive, (amended 2004/108/EC).*
- 2002/95/EC   *ROHS Directive*

The technical documentation required to demonstrate that the products meet the requirements of the Low Voltage Equipment directive has been compiled and is available for inspection by the relevant enforcement authorities.

The CE mark was first applied in: **2008**

**Product Description:**      110V Submersible water pumps  
**Model number(s):**          CSV1A / CSV2A  
**Serial / batch Number:**    Current Manufacture.  
**Date of Issue:**              16/06/2008

Signed

A handwritten signature in black ink, appearing to read "A. Aiken".

A.C. AIKEN  
Senior Manager Clarke International.

# A SELECTION FROM THE VAST RANGE OF

# Clarke®

## QUALITY PRODUCTS

### AIR COMPRESSORS

From DIY to industrial, Plus air tools, spray guns and accessories.

### GENERATORS

Prime duty or emergency standby for business, home and leisure.

### POWER WASHERS

Hot and cold, electric and engine driven - we have what you need

### WELDERS

Mig, Arc, Tig and Spot. From DIY to auto/industrial.

### METALWORKING

Drills, grinders and saws for DIY and professional use.

### WOODWORKING

Saws, sanders, lathes, mortisers and dust extraction.

### HYDRAULICS

Cranes, body repair kits, transmission jacks for all types of workshop use.

### WATER PUMPS

Submersible, electric and engine driven for DIY, agriculture and industry.

### POWER TOOLS

Angle grinders, cordless drill sets, saws and sanders..

### STARTERS/CHARGERS

All sizes for car and commercial use.

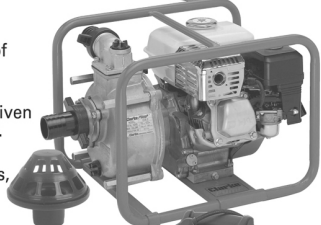
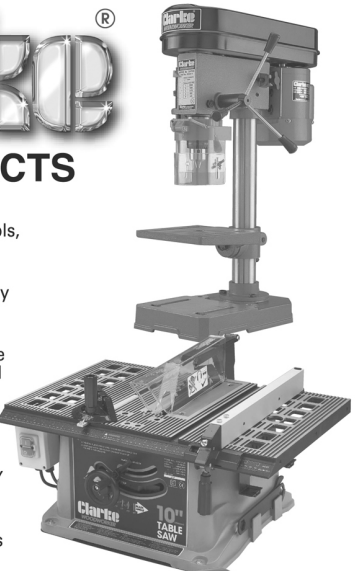

For spare parts and servicing, please contact your nearest dealer, or Clarke International on

**020 8988 7400**

e-mail: [Parts@clarkeinternational.com](mailto:Parts@clarkeinternational.com) e-mail: [Service@clarkeinternational.com](mailto:Service@clarkeinternational.com)

**Clarke** INTERNATIONAL  
Hemnal Street, Epping, Essex CM16 4LG