

## MONSOON

# Installation, Operation & Maintenance Instructions

Please leave this instruction booklet with the home owner as it contains important warranty, maintenance and safety information.



**Read this manual carefully before commencing installation.**

This manual covers the following products:

**Monsoon S2.0 bar Single**

Pt. No. 46497    Pt. No. 46497 ROI  
Pt. No. 46497 EXP

**Monsoon S3.0 bar Single**

Pt. No. 46419    Pt. No. 46419 ROI  
Pt. No. 46419 EXP

**Monsoon S4.5 bar Single**

Pt. No. 46420    Pt. No. 46420 ROI  
Pt. No. 46420 EXP

**Monsoon S1.5 bar Twin**

Pt. No. 46506    Pt. No. 46506 ROI  
Pt. No. 46506 EXP

**Monsoon S2.0 bar Twin**

Pt. No. 46415    Pt. No. 46415 ROI  
Pt. No. 46415 EXP

**Monsoon S3.0 bar Twin**

Pt. No. 46416    Pt. No. 46416 ROI  
Pt. No. 46416 EXP

**Monsoon S4.0 bar Twin**

Pt. No. 46417    Pt. No. 46417 ROI  
Pt. No. 46417 EXP

**Monsoon S4.5 bar Twin**

Pt. No. 46418    Pt. No. 46418 ROI  
Pt. No. 46418 EXP

**FOR POSITIVE HEAD APPLICATIONS**

**Please note images are representative only and may not portray  
your model**



**CONTENTS**

1 PRODUCT OVERVIEW .....1

2 WARNINGS ..... 2

3 CHECKLIST ..... 4

4 REGIONAL SUITABILITY ..... 5

5 IMPORTANT FACTS - READ BEFORE COMMENCING PUMP INSTALLATION..... 6

6 LOCATION - GENERAL ..... 8

7 PUMP CONNECTIONS ..... 14

8 ELECTRICAL INSTALLATION ..... 19

9 COMMISSIONING .....24

10 MAINTENANCE.....25

11 TECHNICAL SPECIFICATION .....27

12 TROUBLE SHOOTING GUIDE .....32

13 WARRANTY POLICY TERMS AND CONDITIONS .....36

14 DECLARATION OF CONFORMITY..... 38

## **1 PRODUCT OVERVIEW**

### **1.1 Product Description**

Electric motor driven single or twin ended peripheral pump, complete with an automatic control system, consisting of flow switches and electronic controls.

### **1.2 Application**

Monsoon Standard pumps are suitable for positive head installation conditions. The pumps are designed for pressure boosting applications in vented stored hot or cold, clean fresh water systems, where under gravity, some flow (approx. 0.6 l/min) is available. Inlet pressures to the pump and ambient temperatures must not exceed the values given in the technical specifications.

Monsoon Standard Single pumps are not suitable for boosting a single side of a dual flow mixer valve or tap. Consult Stuart Turner for alternative pump.

### **1.3 Storage**

If this product is not to be installed immediately on receipt, ensure that it is stored in a dry, frost and vibration free location in its original packaging.

### **1.4 Environment Protection**

Your appliance contains valuable materials which can be recovered or recycled. At the end of the products' useful life, please leave it at an appropriate local civic waste collection point.

## 2 WARNINGS



- This pump set must not be used for any other application without the written consent of Stuart Turner Limited and in particular, must not be connected directly to the mains water supply.
- This appliance can be used by children aged from 8 years and above and persons with reduced physical, sensory or mental capabilities or lack of experience and knowledge if they have been given supervision or instruction concerning use of the appliance in a safe way and understand the hazards involved.
- Children shall not play with the appliance.
- Cleaning and user maintenance shall not be made by children without supervision.
- The motor casing can become very hot under normal operating conditions. Care must be taken to ensure it cannot be touched during operation.



- The electrical installation must be carried out in accordance with the current national electrical regulations.
- The electrical installation must be installed by a qualified person.
- In the interests of electrical safety a 30 mA residual current device (R.C.D. not supplied) should be installed in the supply circuit. This may be part of a consumer unit or a separate unit.
- Maximum head (closed valve) S1.5 bar twin-15 metres, S2.0 bar twin-20 metres, S3.0 bar twin-30 metres, S4.0 bar twin-40 metres, S4.5 bar twin-45 metres. S2.0 bar single-20 metres, S3.0 bar single-30 metres, S4.5 bar single-45 metres.
- Before starting work on the electrical supply ensure power supply is isolated.
- DO NOT allow the supply cord to contact hot surfaces, including the motor shell, pump body or pipework. The cord should be safely routed and secured by cable clips.
- This appliance must be earthed via the supply cord, which must be correctly connected to the earth point located in the terminal box.



- **The supply cord and internal wiring within the terminal box are routed and secured to ensure compliance with the electrical standard EN 60335-1. It is essential that prior to any disturbance of this internal wiring, all cable routing and securing details are carefully noted to ensure re-assembly to the same factory pattern is always maintained.**
- **If the supply cord is to be changed or is damaged, it must be replaced with a special cord assembly available from Stuart Turner or one of their approved repairers.**

Please read installation details carefully as they are intended to ensure this product provides long, trouble free service. Failure to install the unit in accordance with the installation instructions will lead to invalidation of the warranty.

### 3 CHECKLIST

**IMPORTANT:** With the pump removed from its packaging check for any damage prior to installation. If any damage is found contact Stuart Turner Ltd within 24 hours of receipt.

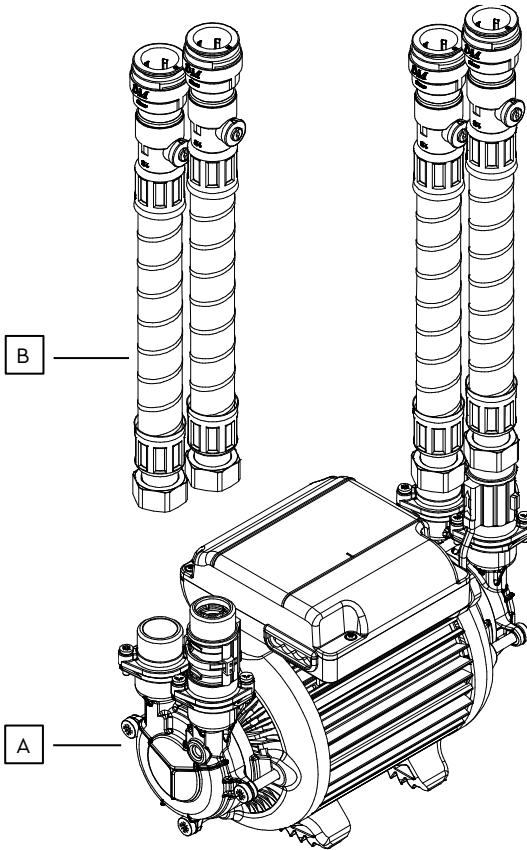

Figure 1

Item	Description	Qty
A	Pump	1
B	Hose & integral washer	4 (2)

Your product may vary slightly from the illustration above.

The quantities shown above are for twin pumps, (single pumps are shown in brackets).

#### 4 REGIONAL SUITABILITY



Before commencing installation, ensure the product you have purchased is correct for your region, to avoid invalidating the warranty.

Check the part number:

Example:

UK product	Pt. No. 46416
ROI product	Pt. No. 46416 ROI
Export product	Pt. No. 46416 EXP

- This installation book refers to UK pipework and pumps supplied with hoses suitable for 22 mm pipework.
- If you have purchased a product suitable for ROI (Republic of Ireland) it will be supplied with hoses suitable for 21 mm pipework.
- If you have purchased a product suitable for Export it will be supplied with hoses suitable for G  $\frac{3}{4}$  connections.

## 5 IMPORTANT FACTS - READ BEFORE COMMENCING PUMP INSTALLATION

### 5.1 Water Storage Capacity

The hot and cold water storage capacity must be sufficient to meet the flow rates required by the pumped equipment and any other water using fittings and appliances, which may be operated simultaneously.

Ensure the pump is primed as described in the priming section before starting, damage to the shaft seal will result otherwise. See Section 9- Commissioning.

### 5.2 Water Temperature

The water entering the pump must be controlled as follows:

- The maximum allowable water temperature is 65 °C.
- The minimum allowable water temperature is 4 °C.
- **DO NOT** fit a pump if the hot water is heated via a method whereby the water temperature cannot be controlled, such as solar or solid fuel you must consult the TechAssist team on +44 (0) 800 31 969 80.

### 5.3 Minimum Flow

For this pump to operate correctly there must be a minimum gravity flow of at least 0.6 l/min through all outlets to be pumped.

### 5.4 Pipework – General

**Secure pipework:** Ensure pipework to and from pump is independently supported & clipped to prevent forces being transferred to inlet and outlet branches of pump.

**Flux:** Solder joints must be completed and flux residues removed prior to pump installation (**flux damage will void any warranty**).

**Pipework design:** Care should be taken in the design of pipework runs to minimize the risk of air locks e.g. use drawn bends rather than 90° bends.



- **DO NOT** introduce solder flux to flexible hoses, pumps or pump parts manufactured from plastic.
- **DO NOT** allow contact with oil or cellulose based paints, paint thinners or strippers, acid based descalents or aggressive cleaning agents.



- **DO NOT** install a non-return valve, or devices which contain non-return valves, in the suction (inlet) pipework to the pump. The pump must be free to vent to the supply tank at all times.
- **DO NOT** bend the flexible hoses beyond 30°. They must be installed as straight as possible.
- **DO NOT** connect this pump to the mains water supply.



## **5.5 Plumbing Installation Regulations**

The plumbing installation must comply with the current water and building regulations.

The plumbing installation must be installed by a qualified person.

## 6 LOCATION - GENERAL



- **Access:** For emergencies and maintenance the pump must be easily accessible.
- **Protection:** The pump must be located in a dry position, frost free and protected from freezing, particularly when installed in a loft (not recommended).
- **Ventilation:** Ensure an adequate air flow to cool the pump. Separate the pump from other appliances that generate heat. An 80 mm (3 ") air gap must be maintained around the pump.
- **Safety:** The motor casing can become very hot under normal operating conditions. Care must be taken to ensure it cannot be touched during operation.
- **Water retention:** Site the pump in a location where in the unlikely event of a water leak, any spillage is contained or routed to avoid electrics or areas sensitive to water damage.
- **Static inlet pressure:** Before deciding where to locate the unit, check to ensure the static inlet head between pump and the bottom of the cold water tank (Figure 2 and Figure 3), is at least 0.5 metres and does not exceed the max inlet head of 14 metres.
- **Ambient temperature:** The pump must be sited in a location where the maximum ambient temperature does not exceed 40 °C.
- **Pipework:** For optimum performance pipework **MUST** be 22 mm (21 mm in RO). Pipework should only reduce to 15 mm when entering terminal fitting.
- **Noise:** The anti-vibration mounting feet and flexible hoses which are supplied as standard, and a precaution to reduce noise transmission, however care must be taken when mounting the pump that any noise is not amplified through loose panels or pipework. **Do not screw down the pump.**



- **Direction of flow:** Ensure the water flow is in the direction of the arrow that is marked on the flow switch reed clamp (vertically upwards).
- **Flexible hoses:** Only use the Stuart Turner hose set supplied with the pump.
- **Isolating valves:** Separate system isolating valves (non restrictive) must be fitted to allow easy pump service.

## 6.1 Preferred Pump Location

The pump must, for optimum performance, be sited as close as possible to and never more than 4 metres from the HOT WATER cylinder. The pump should always be sited BELOW the HOT WATER take-off from the cylinder. The pump location is also dependent on limitations of the static inlet and outlet heads of the installation. For guidance on limitations and recommended location, consult the following relevant section for hot or cold water installation.

### Location – Single Pump

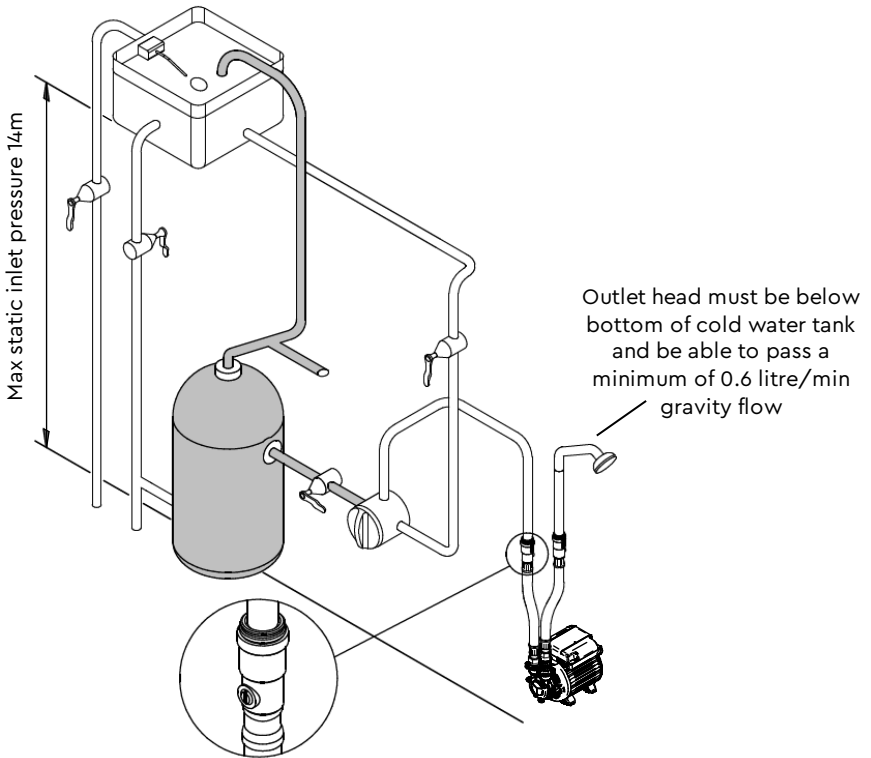

Figure 2

## Location - Twin Pump

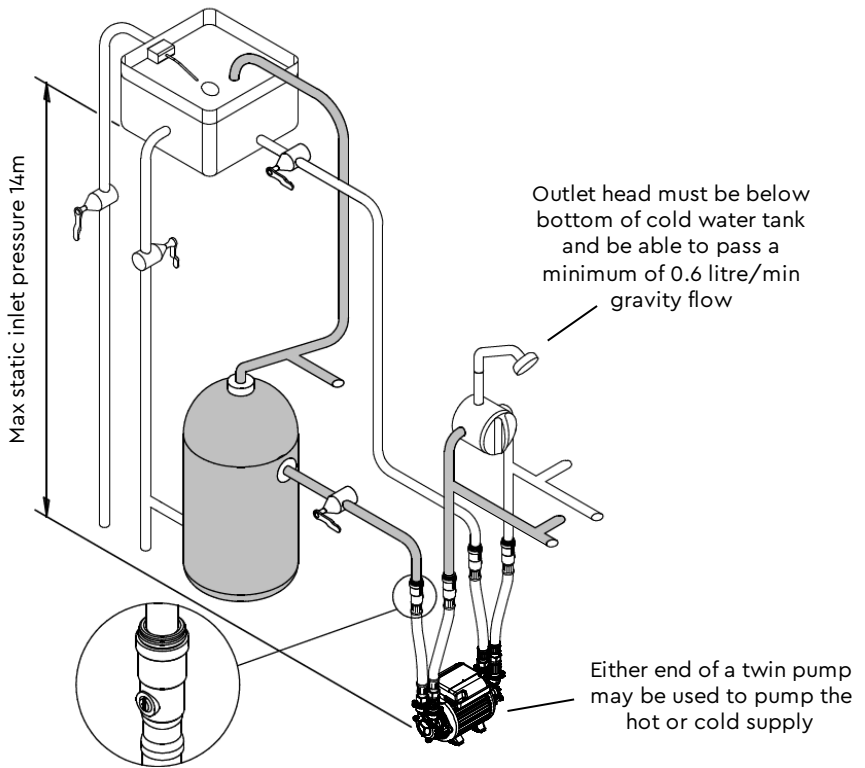

Figure 3

## 6.2 Non-Preferred Pump Location

The pump must be located with at least 0.5 metres flooded suction at all times. If it is necessary to position the pump above the secondary tapping on the hot cylinder it is fed by, the risk of introducing air will be increased.

To avoid this risk one of the two following solutions must be adopted:

- a. The use of a Top Entry cylinder flange.
- b. The use of a Side Entry (SE) cylinder flange, which should have the addition of an inverted loop ("U" bend) of 350 mm minimum drop before rising to the pump, located as close as possible to the cylinder wall. Please note both flange options listed above are designed to suit 22 mm pipework.

If used in ROI a suitable adaptor to 21 mm pipe must be used (not supplied).

This will ensure the pump receives an air free supply and the cylinder vents any air up the vent pipe and not the pump feed (Fig 4 and Fig 5).

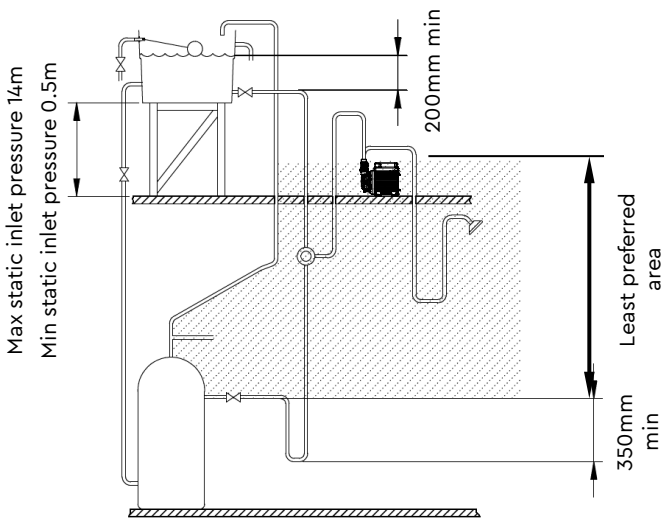

Figure 4  
Standard Single Pump

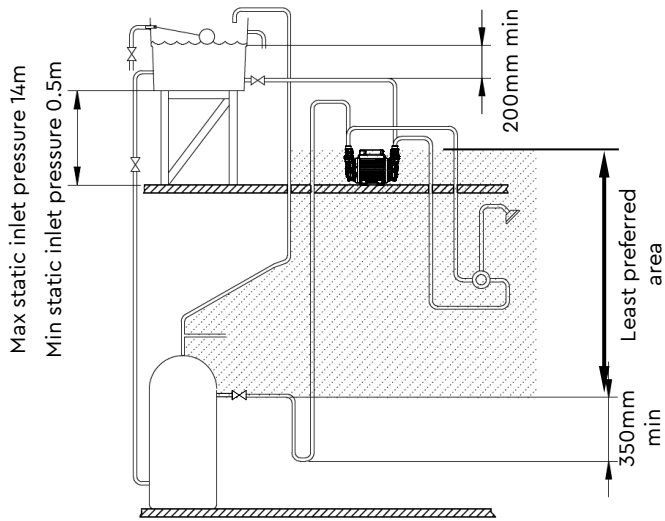

Figure 5  
Standard Twin Pump

## 6.4 Cold Water Connection

**The cold water supply: Must be a DEDICATED AIR FREE** supply via a tank connector, and must be positioned at a slightly lower level (25 mm minimum) than the feed pipe to the hot water cylinder.

Ensure that the pipework size from the cold water tank is 22mm minimum.

**Do not connect to the mains.**

## 6.5 Hot Water Connection

**Hot water cylinder or storage tank:** When a hot water cylinder or storage tank is used, ensure the pipework size from the cold water storage to the hot water storage is of adequate size and a minimum of 22 mm for all model except the S4.5 bar twin which should be a minimum of 28 mm.

**Hot water supply:** The pump **must be** supplied with a **dedicated feed** direct from the hot water cylinder or storage tank, ensuring an air free connection to the pump. We recommend the use of either the Side Entry Flange (SE) Part No 27900 or a Top Entry Flange (TE) Part No 27800 (for all models except the S4.5 bar Twin; S4.5 bar Twin should only use 'A' or 'D'). Please note both flange options listed above are designed to suit 22 mm pipework. If used in ROI a suitable adaptor to 21 mm pipe must be used (not supplied).

**Expansion pipe:** When the method of connection is to be made via the expansion pipe, the **BASE** of the cold water storage tank **MUST** be at least 1 metre above the connection/take off of the hot water storage cylinder feeding the pump.

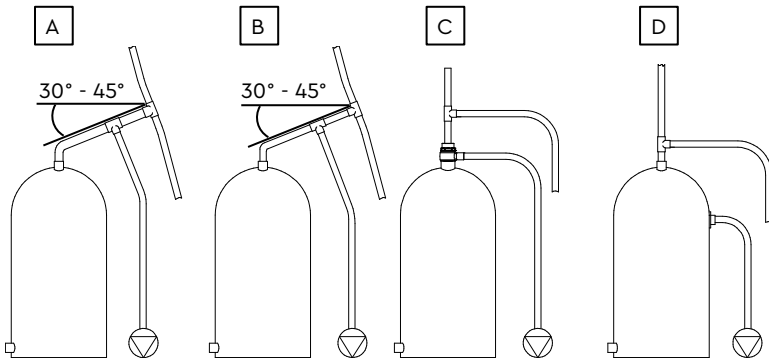

Off expansion pipe with rising 28mm offset reducing to 22mm pipework to pump and expansion pipe.

Off expansion pipe with rising 22mm offset and 22mm pipework to pump.

Top Entry Flange (Part No 27800) with 22mm pipework to pump.

Factory installed G $\frac{3}{4}$  secondary tapping with 22mm pipework to pump.

Or  
Side Entry Flange (Part No 27900) with 22mm pipework to pump.



**For applications in ROI pipe sizes above should read 21 mm.**

Figure 6

## 7 PUMP CONNECTIONS



- Do not use stainless steel, chrome or nickel plated pipe with the flexible hose push-in plumbing connections.
- Do not introduce solder flux into the joint or surrounding area as connectors will be attacked and will fail.
- All solder joints should be completed and flux residues removed before final connection to push-in connections, on the flexible hose.
- Do not allow contact with oil or cellulose based paints, paint thinners or strippers, acid based descalents or aggressive cleaning agents.
- Never operate pump with inlet and/or outlet isolating valves in the closed position. Damage will occur!

### 7.1 Flexible Inlet and Outlet Hoses

The pump inlet and outlet ports are threaded G ¾ M. These ports are provided with a flat sealing face suitable for use with an appropriately sized flat faced fitting and fibre or rubber washer. Ensure a water tight seal is achieved when the pump is both stationary and running.

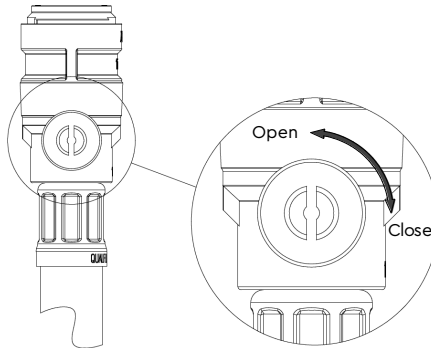

Figure 7

Use correct tool for opening and closing integrated isolating valve to prevent damage.

**Please note** these valves are of quarter turn design, rotate clockwise to close and anti-clockwise to open. Failure to comply with these instructions could lead to valve damage.

**WARNING:** Pump must not run with valve closed.

Flexible hoses with integral isolating valves **do not** replace system isolation valves which must be installed.



## 7.2 Hose to Pump

The pump inlet and outlet ports have factory assembled fittings which are specifically designed for connection to the G  $\frac{3}{4}$  F running nuts on the flexible hoses.

The hose end is fitted with a rubber sealing washer which is held captive within the nut assembly.

Locate the hose into position and screw the nut fully onto the fitting by hand.

Finally nip tight with a spanner (4/5 Nm) for a water tight seal (**do not overtighten**).

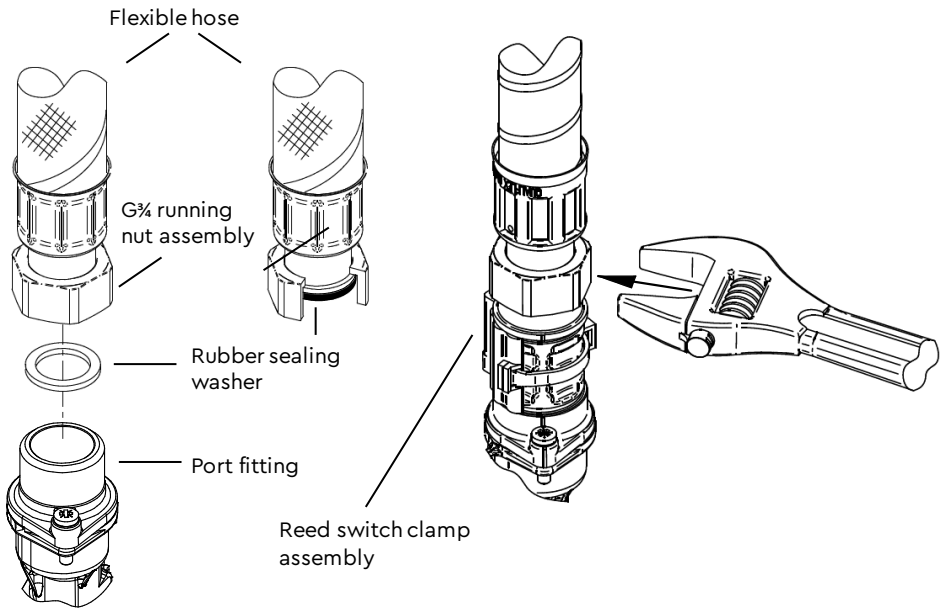

Figure 8

**Note:** When tightening or loosening the hose nut assembly, it is not necessary to use an additional spanner. Place the spanner as shown, do not over tighten the hose assembly.

After tightening ensure the reed switch clamp assembly has not been displaced and is correctly located in the machined groove, see Figure 17 for reference.

### 7.3 Hose to Pipework

The hoses are fitted with plastic push-in connectors, which must only be connected to the following:

22 mm dia. pipework in the UK.

21 mm dia pipework in the ROI.

1. Ensure the pipe is free from all score marks and deformities in the area of the insertion depth (Figure 9) and cut the pipe square, removing all burrs and sharp edges to prevent damage to the sealing O-ring.
2. Prior to inserting pipe into fitting, mark the insert depth on the wall of the pipe with a soft pencil at a distance of 33 mm from the end to be inserted.

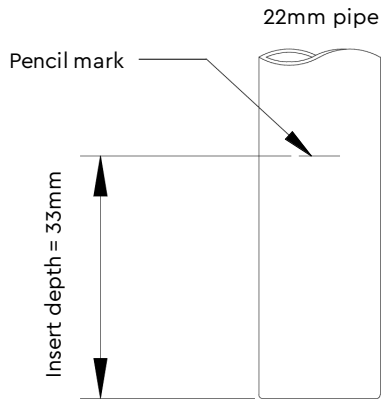

Figure 9

3. Check in the mouth of the fitting that the 'O'-ring, nylon washer and collet are in position as shown in Figure 10.

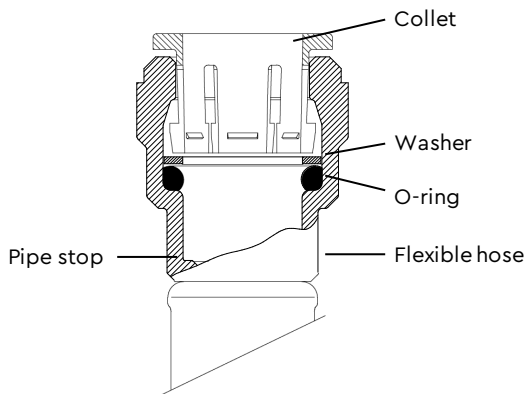

Figure 10

4. Push the pipe firmly into the fitting, until pencil mark is level with the top of the collet and the pipe stop resistance is felt. Pull on the pipe to check it is secure and correctly fitted.
5. To release the joint, push pipe firmly into fitting, hold collet down and gently remove pipe. If the system has been filled with water care should be taken to isolate pump and towels used to absorb spilled water.

#### 7.4 Typical Low Level Installation

In certain installations it may be necessary to install a 90° bend on the inlet or outlet connections of the pump before the flexible hose to accommodate a low level installation.

Below are some preferred connection options. All connections seal on the pump body using a fibre or rubber sealing washer. Tap connector fittings should be used which must be of an appropriate pressure and temperature rating.

It is essential when using any of the fittings shown below, that a correct water tight seal is obtained between the pump body and selected fitting and also the flexible hose and selected fitting. If in doubt contact the fitting manufacturer and confirm compatibility with the connection to be sealed.

Carefully check connections and pipework for leaks whilst pump running and stationary before leaving the installation unattended.

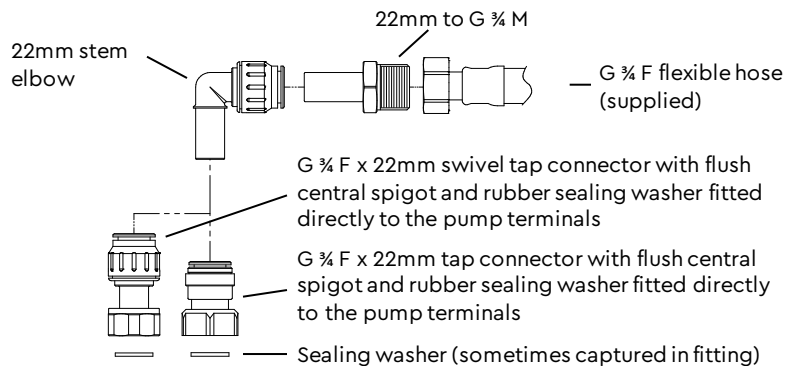
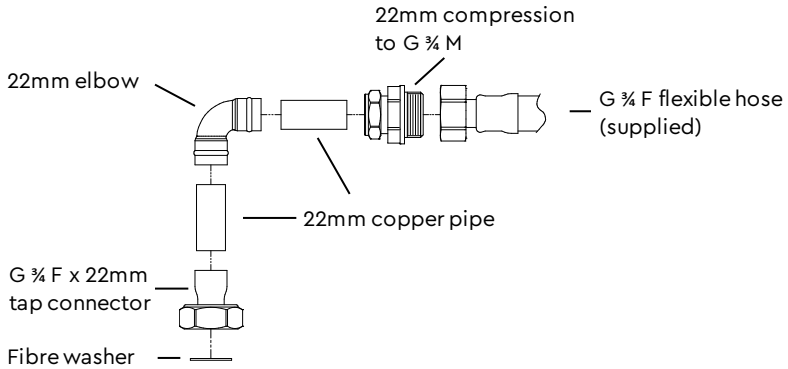
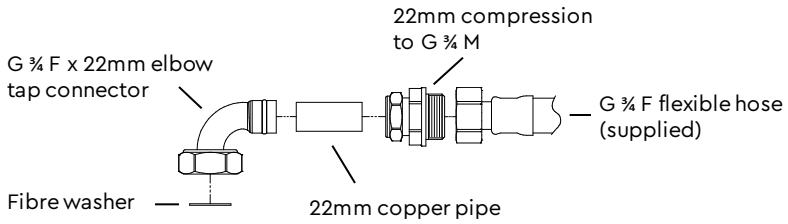

**For applications in ROI pipe sizes above should read 21 mm.**

Figure 11

**If you have any concern either about using push-in fittings or should the joint leak on final test, isolate the water supplies and contact TechAssist on +44(0) 800 31 969 80.**

## 8 ELECTRICAL INSTALLATION



- **Regulations:** The electrical installation must be carried out in accordance with the current national electrical regulations and installed by a qualified person.
- **Safety:** In the interests of electrical safety a 30 mA residual current device (**R.C.D. not supplied**) should be installed in the supply circuit. This may be part of a consumer unit or a separate unit.
- Before starting work on the electrical supply ensure power supply is isolated.
- **DO NOT** allow the supply cord to contact hot surfaces, including the motor shell, pump body or pipework. The cord should be safely routed and secured by cable clips.
- **Adjacent pipes:** Adjacent suction and delivery pipes should be fitted with earthing clamps and connected with earthing wire size 4 mm<sup>2</sup> (Figure 12).

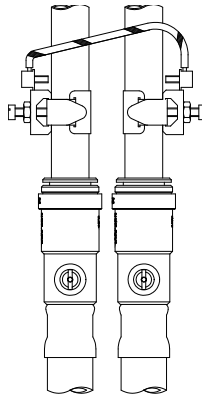

Figure 12

Earth continuity connections

- **Earthing:** This appliance must be earthed via the supply cord, which must be correctly connected to the earth point located in the terminal box.
- **Pipework:** Copper or metallic pipework must have supplementary earth bonding where the continuity has been broken by flexible hoses or plastic components.
- **Additional earthing:** Certain installations may require additional earthing arrangements such as equipotential bonding. Reference should be made to the relevant regulations concerning this subject to ensure compliance.

**Connections:** The pump must be permanently connected to the fixed wiring of the mains supply using the factory fitted supply cord, via a double pole switched fused spur off the ring main and **NOT** connected to the boiler or the immersion heater circuits.

## 8.1 Wiring of Connection Unit



**WARNING: This appliance must be earthed.**

The wires in the mains lead (supply cord) are coloured in accordance with the following code:

- Green and Yellow: Earth
- Blue: Neutral
- Brown: Live

As the colours of the wires in the mains lead of this appliance may not correspond with the coloured markings identifying the terminals in your connection unit proceed as follows:

- The wire which is coloured green and yellow must be connected to the terminal in the connection unit which is marked with the letter E or by the earth symbol:  $\oplus$  or coloured green or green and yellow.
- The wire which is coloured blue must be connected to the terminal which is marked with the letter N or coloured black.
- The wire which is coloured brown must be connected to the terminal which is marked with the letter L or coloured red.

## 8.2 Fuses

The following fuse size should be used with the appropriate pump.

Model	Fuse Size (AMPS)
S4.0 bar Twin	13
S4.5 bar Twin	
All other Models	5

### 8.3 Wiring Diagrams



- Parallel wiring of two single pumps is not recommended.

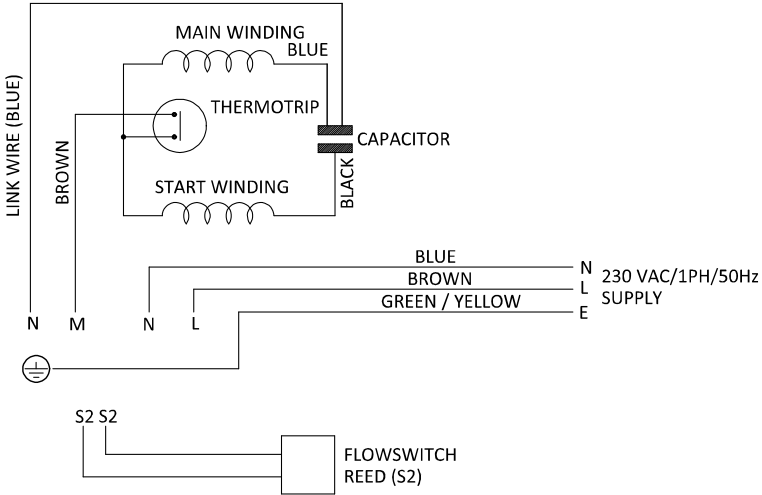

Figure 13  
Single Models

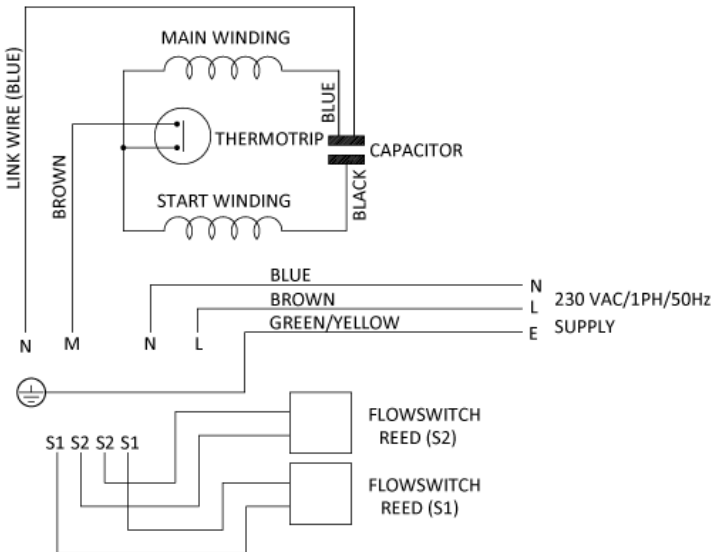

Figure 14  
Twin Models



## 8.4 Supply Cord Replacement



The supply cord and internal wiring within the terminal box are routed and secured to ensure compliance with the electrical standard EN 60335-1. It is essential that prior to any disturbance of this internal wiring, all cable routing and securing details are carefully noted to ensure re-assembly to the same factory pattern is always maintained.

If the supply cord is to be changed or is damaged, it must be replaced with a special cord assembly available from Stuart Turner or one of their approved repairers.

On disassembly note the cord retention and routing system. Re-assemble to the same pattern.

For information on cable connection consult the wiring diagram and cable gland fitting instructions.

## 8.5 Cable Gland Fitting Instructions

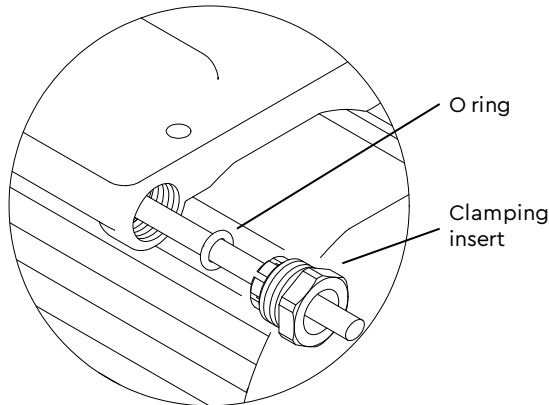

Figure 15

To enable correct assembly of the cable gland the 'O'-ring must be placed over the cable before the clamping insert can be tightened.

**Note:** Cable diameter range:- 6.5 mm to 9.5 mm.

## 8.6 Supply Cord Extension

The pumps are fitted with a supply cord to the following specification:

All models - HO5VV-F3 G 0.75 mm<sup>2</sup> - 6 Amp rated cable.

If the supply cord is to be extended, a cord of the same specification should be used. Any connections or junction boxes used should be specifically suited for the application and installed in accordance with the manufacturers instructions.

## 9 COMMISSIONING



**System Flushing:** This pump incorporates push-in connectors and plastic components that must not come into contact with solder flux, acid-based descalents or aggressive cleaning agents. The pipework system should be flushed out prior to the pump being connected to ensure any contaminants/chemical residues and foreign bodies are removed from elsewhere in the system.

**Water Supply:** Always ensure that water storage capacity is adequate to meet the demand. Ensure the pump chamber is full of water before starting the pump. Failure to do this could result in seal damage. To ensure dry running does not occur the pump must be primed as described in priming section below. **Do not run pump dry.**

### 9.1 Priming



**Never operate pump with inlet and/or outlet isolating valves in the closed position. Damage will occur!**

The pump must be primed (filled with water) before starting.

Turn on water supply from the system service valves, prime and vent the pump by opening the pump inlet and outlet isolating valves to allow pump to fill and vent.

In the case of twin pumps, both pump chambers must be independently primed.

### 9.2 Starting

1. Switch on power and open terminal fitting. Pump should start.
2. Open and close all outlets in turn associated with the pump, (including w/c systems) allowing water to flow from each outlet until all air is purged. As each outlet is opened and closed, the pump will start and stop respectively.
3. The tap or control valve within the system when opened and closed will now turn the pump on/off. If this is confirmed to be the case, the system is now operating correctly.
4. Carefully check pump and pipework for leaks whilst pump running and stationary before leaving the installation unattended.

**For Further Technical Support:** Phone the Stuart Turner TechAssist team on +44 (0) 800 31 969 80. Our staff are trained to help and advise you over the phone.

## 10 MAINTENANCE



Turn off water supplies to the pump and release pressure by opening water outlets before attempting maintenance

### 10.1 Inlet Strainer

The inlet strainers may require periodical cleaning. The frequency of this operation is dependent upon installation conditions. The strainer is located in the inlet assembly of the pump casing and is removed as follows:

1. Isolate pump electrically.
2. Release all system pressure.
3. Isolate hot and cold water supplies via the integral pump isolating valve located in the flexible hoses and release hose nuts connected to the pump (see Section 7- Pump Connections).
4. Remove M4 screws (2 off) from inlet assembly, lift brass inlet fitting (with O-ring) away from pump casing (Figure 16).
5. Remove strainer with long nose pliers noting location lug position upon removal (Figure 16) and clean thoroughly.
6. Refit strainer taking care to position lug in body inlet port location slot and re-assemble pipework. Tighten M4 clamp screws to 1.5 Nm torque.
7. Re-connect flexible hoses and tighten (see Section 7.2).
8. After maintenance is completed refer to Section 9 – Commissioning for instructions on re-starting pump.

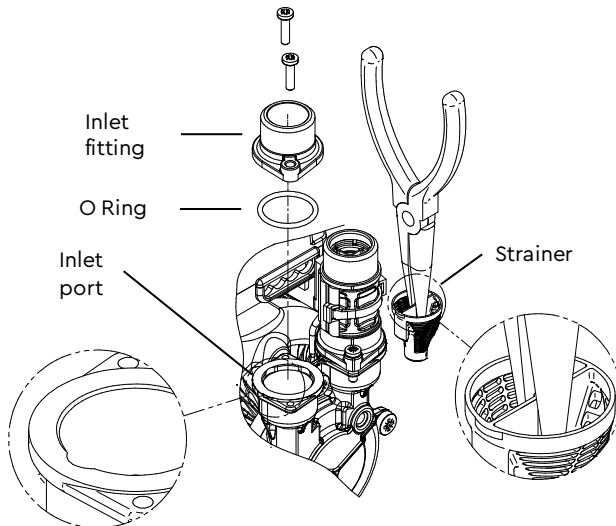

Figure 16

## 10.2 Water Scale

As water is heated scale deposits are released in areas of hard water, scale can cause the mechanical seal to stick if left without use for long periods. The pump must be run for at least 5 minutes every four weeks to "exercise" all working parts. Run on cool water. See Section 11 – Technical Specification for note on water temperature. This particularly applies to guest bathrooms used infrequently.

## 10.3 Cleaners, Disinfectants and Descalents



Acid based descalents and aggressive cleaning agents must not come into contact with the pump. The pump must be removed from the system prior to the use of these products. The system should be flushed to remove all chemicals before the pump is re-connected.

If in any doubt as to the suitability of the chemical solutions, please contact our TechAssist helpline on +44 (0) 800 31 969 80.

No other routine maintenance is required.

## 11 TECHNICAL SPECIFICATION

### 11.1 Single Head Models

Pump Model		S2.0 bar Single 46497	S3.0 bar Single 46419	S4.5 bar Single 46420
General	Warranty	5 years		
	WRAS approval	1904040		
	Approvals	WRAS, UKCA, CE		
Features	Pump type	Peripheral		
	Mechanical seal	EPDM/PTFE/Al. Oxide		
	Anti-vibration feet	✓	✓	✓
	Inlet strainer	✓	✓	✓
	Flexible hoses	2	2	2
	Dry run protection	✓	✓	✓
	Noise (dB(A))	42	48	55
Performance	Maximum head - closed valve	2.0 bar (20 m)	3.0 bar (30 m)	4.5 bar (45 m)
	Performance @ 9 l/min	1.5 bar	2.5 bar	3.5 bar
	Performance @ 18 l/min	0.7 bar	1.6 bar	2.4 bar
	Maximum flow	27 l/min	33 l/min	40 l/min
	Maximum static inlet pressure	14 metres		
	Maximum working pressure*	600 kPa (6 bar)		
	Maximum ambient air temperature	40 °C		
	Min / Max water temperature**	Min 4 °C / Max 65 °C		

	Flow switch sensitivity (Approx)	0.6 l/min		
Materials	Pump body	Brass		
	Impeller	Brass		
Connections	Pump connections	G ¾ M		
Flexible hoses	Connections (UK model)	G ¾ F x 22 mm push-fit x 310 mm long Isolating valves on all hoses		
	Connections (ROI model)	G ¾ F x 21 mm push-fit x 310 mm long Isolating valves on all hoses		
	Connections (Export model)	G ¾ F x G ¾ F x 310 mm long		
Motor	Type	Induction (auto-reset thermal trip)		
	Duty rating	Continuous (S1) @ 9 l/ min and above		
Electrical	Power supply/phase/frequency	230 V a.c. / 1 / 50 Hz		
	Power consumption	245 Watts	385 Watts	555 Watts
	Current (full load)	1.1 Amps	1.7 Amps	2.4 Amps
	Fuse rating	5 Amps		
	Power cable (pre-wired)	1.5 metres		
Physical	Enclosure protection	IPX4		
	Length	200 mm		
	Width	126 mm		
	Height (excluding hoses)	191 mm		
	Weight (including fittings)	5.4 Kg		6.0 Kg

## 11.2 Twin Head Models

Pump Model		S1.5 bar Twin 46506	S2.0 bar Twin 46415	S3.0 bar Twin 46416	S4.0 bar Twin 46417	S4.5 bar Twin 46418
General	Warranty	5 years				
	WRAS approval	1904040				
	Approvals	WRAS, UKCA, CE				
Features	Pump type	Peripheral				
	Mechanical seal	EPDM/PTFE/Al. Oxide				
	Anti-vibration feet	✓	✓	✓	✓	✓
	Inlet strainer	✓	✓	✓	✓	✓
	Flexible hoses	4	4	4	4	4
	Dry run protection	✓	✓	✓	✓	✓
	Noise (dB(A))	48	52	54	56	57
	Performance	Maximum head - closed valve	1.5 bar (15 m)	2.0 bar (20 m)	3.0 bar (30 m)	4.2 bar (42 m)
Performance @ 9 l/min		1.2 bar	1.5 bar	2.5 bar	3.5 bar	3.9 bar
Performance @ 18 l/min		1.1 bar	1.3 bar	2.1 bar	3.0 bar	3.4 bar
Maximum flow		49 l/min	55 l/min	60 l/min	65 l/min	78 l/min
Maximum static inlet pressure		14 metres				
Maximum working pressure*		600 kPa (6 bar)				
Maximum ambient air temperature		40 °C				
Min / Max water temperature**		Min 4 °C / Max 65 °C				
Flow switch sensitivity (approx)		0.6 l/min				

Materials	Pump body	Brass				
	Impeller	Brass				
Connections	Pump connections	G ¾ M				
Flexible hoses	Connections (UK model)	G ¾ F x 22 mm push-fit x 310 mm long Isolating valves on all hoses				
	Connections (ROI model)	G ¾ F x 21 mm push-fit x 310 mm long Isolating valves on all hoses				
	Connections (Export model)	G ¾ F x G ¾ F x 310 mm long				
Motor	Type	Induction (auto-reset thermal trip)				
	Duty rating	Continuous (S1) @ 9 l/ min and above***				
Electrical	Power supply/phase/frequency	230 V a.c. / 1 / 50 Hz				
	Power consumption	345 Watts	425 Watts	600 Watts	890 Watts	1090 Watts
	Current (full load)	1.5 Amps	1.9 Amps	2.8 Amps	4.0 Amps	4.9 Amps
	Fuse rating	5 Amps			15 Amps	
	Power cable length (pre-wired)	1.5 metres				
Physical	Enclosure protection	IPX4				
	Length	265 mm			300 mm	310 mm
	Width	126 mm				
	Height (excluding hoses)	191 mm				
	Weight (including fittings)	7.2 Kg		7.5 Kg	9.4 Kg	9.9 Kg



Stuart Turner reserve the right to amend the specification in line with its policy of continuous development of its products.

**Note:** For information on other voltages/frequencies which are not shown, consult TechAssist on +44 (0) 800 31 969 80.

**\*Note:** The maximum pressure that can be applied to the pump under any installation conditions.

**\*\*Note:** A stored water temperature of 60 °C is considered sufficient to meet all normal requirements and will minimize deposition of scale in hard water areas.

**\*\*\*Note:** Both heads pumping 4.5 l/min and above.



**Maximum permissible water temperature 65 °C.**

**Noise:** The equivalent continuous A-weighted sound pressure level at a distance of 1 metre from the pump does not exceed 70 dB(A).

## 12 TROUBLE SHOOTING GUIDE

### 12.1 General Guide

Symptoms	Probable Cause	Recommended Action
Pump will not start	Insufficient gravity flow.	Check flow rate minimum of 0.6 l/min required on full hot and cold.
	Electrical.	Check power supply. Check fuse (see fuse section). Check circuit breaker is set. Check wiring connections.
	Pump Jammed.	If motor 'Buzzes' switch off power and contact Stuart Turner.
	Integral motor thermotrip activated.	Wait for thermotrip to auto-reset and check that duty point and run time is within specification (see technical specification).
Reduced/ intermittent flow	Incorrect or no anti-aeration flange fitted	Check that the installation complies with installation instructions.
	Incorrect pipe sizes.	Check for correct pipe sizing, see Section 7.
	Blocked inlet filters.	Clean inlet filters (see maintenance section).
	Hot water temperature set too high.	Reduce cylinder stat setting to 65 °C max.
	Blocked shower head spray plate	Clean in accordance with manufacturers instructions.
No hot water	Air locked water feed.	Vent hot water pump of air. Check cold feed to hot water cylinder. Check water level in cold water tank and that all stopcocks and isolating valves are open.
	Heat source not operating.	Check boiler is switched 'on'. Check cylinder thermostat. Check immersion heater. Check cylinder contains hot water.

<b>Symptoms</b>	<b>Probable Cause</b>	<b>Recommended Action</b>
No hot water (contd)	All hot water has been used.	Check tank volume is adequate.
	Faulty thermostatic mixer valve.	Consult makers instructions.
Pump runs on with outlets closed	Leak in system.	Check tap washers, w/c valve washers, pipe joints.
	Damaged reed switch or P.C.B.	If pump continues to run, this indicates a closed circuit in either the flow switch reed or P.C.B. in the terminal box. Contact Stuart Turner.
	Jammed flow switch.	Remove outlet hoses and check that flow switch sits in lowest position. Check float for free movement.
Pump starts with all outlets closed	Air in system.	Bleed through system without pump running until hot and cold services run with no air.
Flexible hose leaks	Not fitted correctly.	Check that the hose is pushed firmly onto the pump inlet/outlet connections and pipework.
	Damaged 'O'-rings.	Check copper pipe ends are cleanly cut and deburred.

## 12.2 Flow Switch Circuit Test

1. First confirm visually that the flow switch reed clamps have not been dislodged during handling or installation. The clamps must be fully located within their flow switch body groove as shown.
2. To carry out the following test you will need to obtain a magnet, a typical fridge magnet is suitable.
3. Ensure the power supply is switched on.
4. Position the magnet directly in front of the reed clamp as shown. If pump does not start, then slowly move the magnet up and down to a position that exceeds the extent of the reed clamp. The pump should instantaneously start at some point during this extent of movement. If this does not happen, this indicates a possible fault with the reed switch or the P.C.B which is located within the terminal box. These should be checked electrically. Consult Stuart Turner for further instructions.

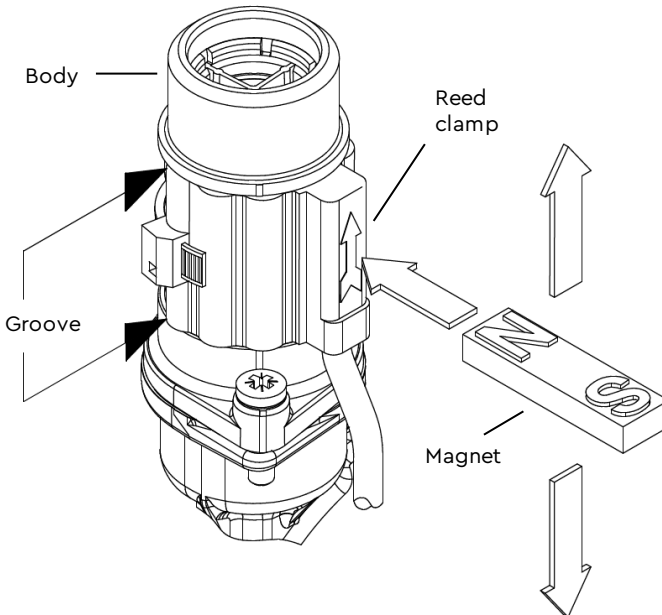

Figure 17

## 12.3 Fault Finding

The PCB is also fitted with a "power on" indicator light. This will remain illuminated when mains power is supplied to the board. The indicator light is located on the PCB within the terminal box.



**This operation should only be carried out by a competent person.**

To view the light the following procedure must be followed:

5. Isolate the mains electrical power supply from the pump.
6. Remove the four screws retaining the terminal box lid (Figure 18).
7. Lift the terminal box lid off.

**IMPORTANT** – Ensure there is no contact with any of the internal parts of the terminal box.

8. Briefly reconnect the mains power supply to the pump – the 'power on light should illuminate if the pump has been correctly wired.
9. Isolate the mains electrical power supply from the pump.
10. Re fit the terminal box lid ensuring no cables are trapped.
11. Re fit the four terminal box lid retaining screws, tighten to 0.8 Nm.

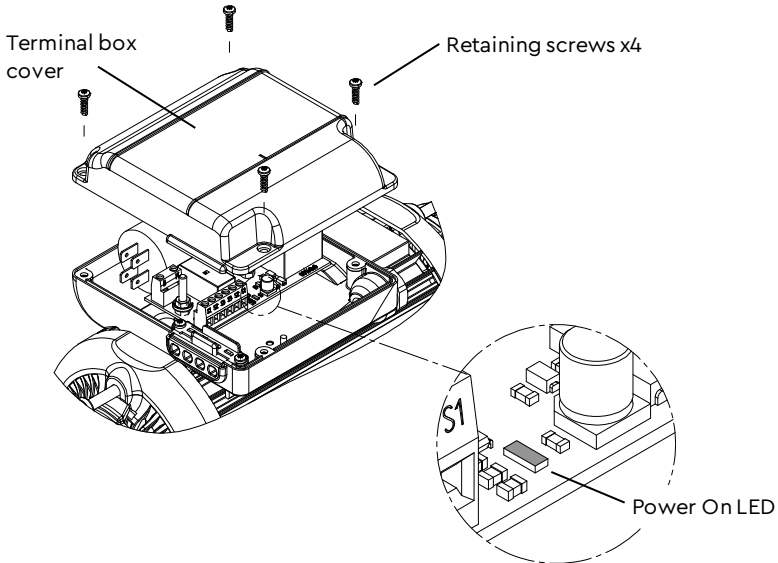

Figure 18  
Wiring removed for clarity

**Note:** This image is for reference only.

## PRODUCT WARRANTY TERMS & CONDITIONS

### Congratulations on purchasing a Stuart Turner product

We are confident this product will provide many years of trouble free service as all our products are manufactured to the very highest standard.

All **Monsoon pumps** are warranted to be free from defects in materials or workmanship for up to **5 years\*** from the date of purchase.

Within the warranty period we will repair, free of charge, any defects in the product resulting from faults in material or workmanship, repairing or exchanging the whole unit as we may reasonably decide.

#### \* Important Note

This extended promotional warranty is only granted under the following conditions:

5. That the product is registered on the Stuart Turner web site within 12 months of the purchase date.
6. That a valid receipt or other acceptable form of 'proof of purchase' such as a copy of the installers invoice/receipt is also uploaded during this registration process.

Product registration to obtain the warranty extension is not a requirement in the Republic of Ireland.

Please register your product here:

<https://www.stuart-turner.co.uk/warranty>

**Failure to register the product within this period, or failure to upload a valid form of proof of purchase will invalidate the promotional extended warranty and the default product warranty of 1 year will be applicable.**

#### Warranty Exclusions

Not covered by this warranty: Damage arising from incorrect installation, improper use, unauthorised repair, normal wear and tear and defects which have a negligible effect on the value or operation of the pump.

This warranty is in addition to your statutory rights as a consumer. If you are in any doubt as to these rights, please contact your local Trading Standards Department.

#### Warranty Claim Procedure

In the event of a claim please telephone 'TechAssist' on **+44 (0) 800 31 969 80**

or email us at [techassist@stuart-turner.co.uk](mailto:techassist@stuart-turner.co.uk)

In the event of a claim within the terms of this warranty policy, your receipt or 'proof of purchase' provided during registration will be reviewed.

You should obtain appropriate insurance cover for any loss or damage which is not covered by Stuart Turner Ltd in this provision.

Please make a note for your own reference:

PRODUCT MODEL	SERIAL NO.	DATE PURCHASED

**NOTES:**



DECLARATION OF CONFORMITY



**Supply of Machinery Regulations - 2008**

EN ISO 12100:2010, EN 809:1998+A1:2009/AC:2010

**Electrical Equipment Regulations - 2016**

EN 60335-1:2012/A2:2019, EN 60335-2-41:2003/A2:2010

**EMC Regulations - 2016**

EN 55014-1:2017/A11:2020, EN 55014-2:2015, EN 61000-3-2:2014, EN 61000-3-3:2013

**EMF Regulations - 2016**

EN 62233:2008

**RoHS Regulations - 2012**

EN IEC 63000:2018

**Machinery Directive - 2006/42/EC**

EN ISO 12100:2010, EN 809:1998+A1:2009/AC:2010

**Low Voltage Directive - 2014/35/EC**

EN 60335-1:2012/A2:2019, EN 60335-2-41:2003/A2:2010

**EMC Directive - 2014/30/EU**

EN 55014-1:2017/A11:2020, EN 55014-2:2015, EN 61000-3-2:2014, EN 61000-3-3:2013

**EMF Directive - 1999/519/EC**

EN 62233:2008

**RoHS Directive - 2011/65/EU**

EN IEC 63000:2018

**WEEE Directive - 2012/19/EU**

IT IS HEREBY CERTIFIED THAT THE STUART ELECTRIC MOTOR DRIVEN PUMP AS SERIAL NUMBER BELOW, COMPLIES WITH THE ESSENTIAL REQUIREMENTS OF THE ABOVE STATUTORY REGULATIONS & E.U. DIRECTIVES.



STUART TURNER LIMITED  
HENLEY-ON-THAMES, OXFORDSHIRE  
RG9 2AD, ENGLAND.

RESPONSIBLE PERSON AND MANUFACTURER

Signed.....

EU AUTHORISED REPRESENTATIVE

ARC (AUTHORISED REP COMPLIANCE)  
GND FLOOR, 71 LOWER BAGGOT  
STREET, DUBLIN,  
D02 P593, IRELAND.

Stuart Turner are an approved company to BS EN ISO 9001:2015



Stuart Turner Ltd, Henley-on-Thames, Oxfordshire RG9 2AD ENGLAND

Tel: +44 (0) 1491 572655 Fax: +44 (0) 1491 573704

info@stuart-turner.co.uk | www.stuart-turner.co.uk