



MAINSBOOST **VariQ** **BOOSTER PUMP**

STUART-TURNER.CO.UK

**STUART
TURNER** 

ABOUT US

We are a UK manufacturer of pump and water boosting solutions with an unprecedented reputation for product quality, reliability, innovation and customer service.

Customers can expect nothing but the best product, using the latest technology, manufactured to the highest quality standards, resulting in the most reliable solution available.

All our products are designed and manufactured to exacting standards right here in the UK.

Most installations can be satisfied from our standard range of products, however, if you need a more tailored solution, our unique manufacturing facility combined with our technical expertise means we can provide bespoke options specifically aimed at commercial and OEM markets.

Telephone: **TechAssist +44 (0) 800 31 969 80** e-mail **info@stuart-turner.co.uk**
or visit the support section of the Stuart Turner website to find our specialist in your area.
stuart-turner.co.uk



UNRIVALLED SUPPORT

We are specialists in our field, with a dedicated team able to offer help at every stage.

DESIGN EXPERTISE

Our expert team can conduct a detailed analysis of the performance requirements of the intended project to produce a fully costed proposal. All our systems are custom designed in-house using the latest CAD software to develop, evaluate and aid the design of the most efficient solution for your specific needs.



COMMISSIONING

We provide a full commissioning service on all our systems and are available to advise on the installation of your system should you require our technical help or practical expertise.



MANUFACTURING EXCELLENCE

We have invested in the latest production and manufacturing technologies to ensure we work to the highest quality standards. This guarantees our system reliability whilst at the same time minimising costs, improving efficiency and delivering on time and in full.

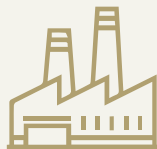

MAINTENANCE

Ongoing maintenance is a cost-effective solution to prolonging the life of your system and maximising its operational efficiency. To ensure the system continues to operate effectively and reliably we can also offer a comprehensive maintenance and service contract.

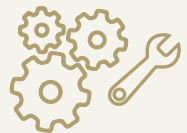

TECHNICAL TRAINING

We offer a range of CPD courses aimed at building service engineers and accredited by CIBSE – Chartered Institution of Building Service Engineers. CIBSE is an internationally recognised professional association that supports construction and engineering industries by delivering up-to-date knowledge of the built environment to its membership through training and education.

Visit the **CIBSE** website for further details.



ON-GOING SUPPORT

The quality and reliability of our products and services are second to none, allowing you peace of mind when you specify Stuart Turner. However, should you experience any issues we have a dedicated team of technical experts available to help. The TechAssist team are available to offer technical advice or guidance on any aspect of product selection.

Technical helpline:
TechAssist 0800 31 969 80



INTRODUCING

MAINSBOOST

VariQ

COMPACT DESIGN

Mainsboost VariQ

STAINLESS STEEL PUMP HOUSING

Constant water pressure, any time, every time!

The Mainsboost VariQ offers a variable speed, intelligent, energy efficient and quiet water boosting pump.

The Mainsboost VariQ is designed to boost water performance from a cold water storage tank, roof tank or ground tank in domestic and light commercial applications and is ideal for many properties with up to 3 floors and up to 8 outlets in operation simultaneously.

Even if multiple outlets, showers and appliances are running at the same time, the speed of the pump will adjust automatically to meet demand without any noticeable drop in water pressure.





QUIET FAN COOLED ELECTRIC MOTOR



INTRODUCING

MAINSBOOST

VariQ

High performance, high reliability, high efficiency...low noise!

Not only good looking but intelligent too! The NEW VariQ from Stuart Turner provides the ideal water pressure, any time, every time. This compact, packaged variable speed pump is designed for water supply and pressure boosting in domestic applications and did we mention, it is oh so Quiet!

The whole house water boosting VariQ really has it all. Intelligent variable speed water boosting pump, automatically adjusts according to water demand without loss of pressure to multiple outlets. Energy efficient technology. Compact yet powerful, up to 97 litres/minute.

Intelligent variable speed pump control

Ideal for domestic and light commercial applications, the VariQ fully packaged water boosting pump offers intelligent pump controls, built in reliability and is suitable for multiple applications.





GOOD TO KNOW

- Compact
- Powerful
- Variable speed and intelligent control
- Built in reliability
- Sshh – Oh so quiet
- Easy installation

Mainsboost VariQ Features and benefits

The Mainsboost VariQ is designed to boost water performance from a cold water storage tank, roof tank or ground tank in domestic and light commercial applications and is ideal for many properties with up to 3 floors and up to 10 outlets in operation.

This compact, quiet and powerful pump offers a wealth of features and benefits making it the ideal choice for many variable speed water boosting applications.



Performance

- Boost pressure up to 5.5 bar
- Boost flow up to 97 litres/min
- Variable speed intelligent control
- Quiet operation
- Self priming up to 6 metres

Quality

- ISO 9001:2015
- Built-in safety – low voltage controls
- Conforms to BS EN 60335
- CE compliant product

Reliability

- 2 year warranty
- Robust construction
- Continuously rated
- Dry run protection

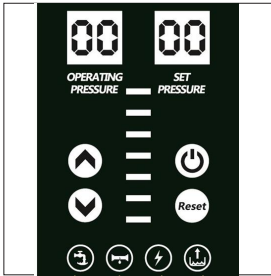

Intuitive control panel

Illuminated touch screen and control panel gives a clear and easy to understand indication of pump settings and operating status.

User friendly operation

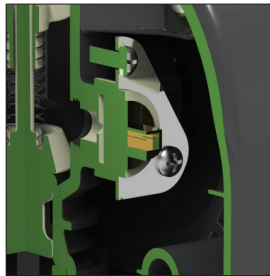

Built-in pressure sensor

An integrated pressure sensor monitors the pump outlet pressure and continuously adjusts the pump speed to maintain a constant water pressure at all outlets.

Constant pressure

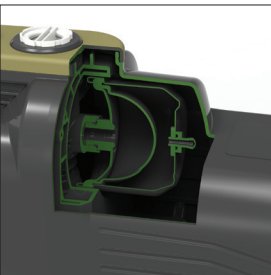

Pressure vessel

An integrated pressure vessel operates in conjunction with the non-return valve to enable the pump to start under both negative head and positive head installation applications.

Universal applications

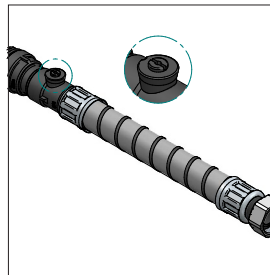

Flexible connection hoses

Optional connecting hose kits are available. Consisting of two 300mm long, metal braided, anti-vibration flexible hoses with G1 threaded connections to the pump. Fitted with isolation valves and available in formats to suit the UK and ROI.

Easy installation

Mainsboost VariQ Features and benefits

Variable speed and intelligent control

The intelligent pump control is equipped with a built-in sensor which continually monitors pressure and flow, automatically adjusting the pump to meet demand throughout the property. For example, if an outlet is opened it will operate at a minimum level and to the required pressure. However, if another outlet is opened or a shower is switched on, the VariQ will automatically adjust to compensate for loss of pressure and boost inlet water pressure to fully meet the increased demand.

Built in reliability

Mainsboost VariQ integrates a high performance, continuously rated centrifugal pump, pressure vessel, pressure sensor, non-return valve and intuitive control panel in to one compact and easy to install package.

Sshh – Oh so quiet

The Mainsboost VariQ has been designed to minimise noise emissions and from 61dB (A) is very quiet. Supplied as an integrated system with all component parts neatly encased within its robust exterior, coupled with a air-cooled permanent magnet motor, the Mainsboost VariQ is one of the quietest water boosting pumps on the market.

Easy installation

The intuitive, illuminated touch screen control panel makes setting up extremely easy. The display identifies pressure values, pressure mode, pump running/standby mode, adjustment controls and in the unlikely event that anything should go wrong, fault codes to help identify the problem.

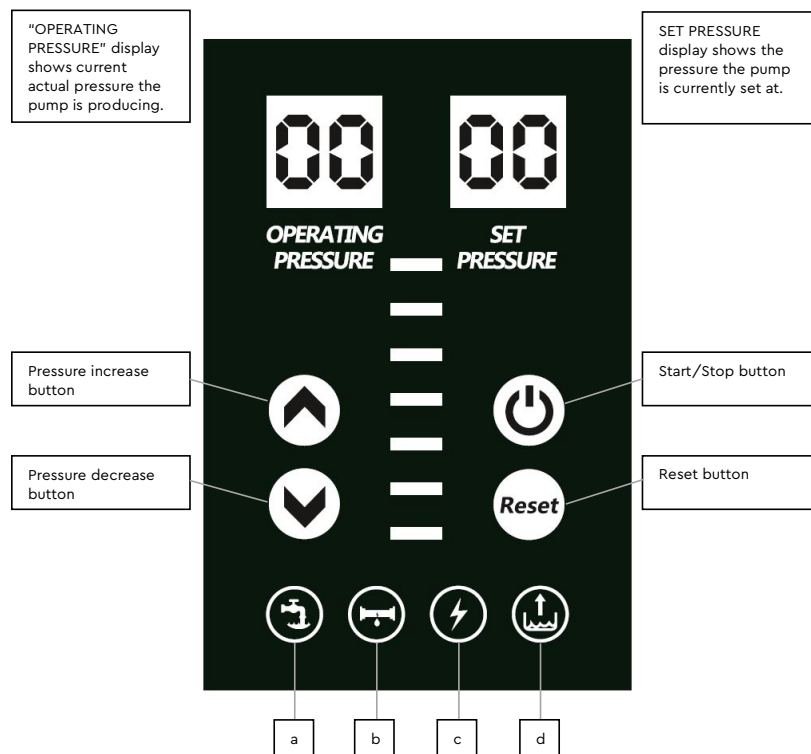

a) Pump is 'ON'

b) Leakage detected in pipeline: check where possible for leaks or contact appropriately qualified person.

c) Voltage protection: input voltage has fallen out of specification for pump, contact appropriately qualified person for correction.

d) Dry run detected.

Mainsboost VariQ Applications

Mainsboost VariQ is extremely versatile and can be used to boost the water supply from a cold water storage tank directly to the entire property; boosting cold water outlets directly and hot water outlets via the existing combination boiler or pressurised hot water cylinder.

Boosting from a break tank in the roof space

The Mainsboost VariQ can be used to boost pressure and flow to the entire property from a cold water break tank in the roof space.

Ideal when converting an open-vented hot water cylinder system to an un-vented hot water cylinder system and enables the re-use of the existing break tank.

The Mainsboost VariQ can easily provide the minimum pressure and flow rates recommended for modern pressurised hot water cylinders.

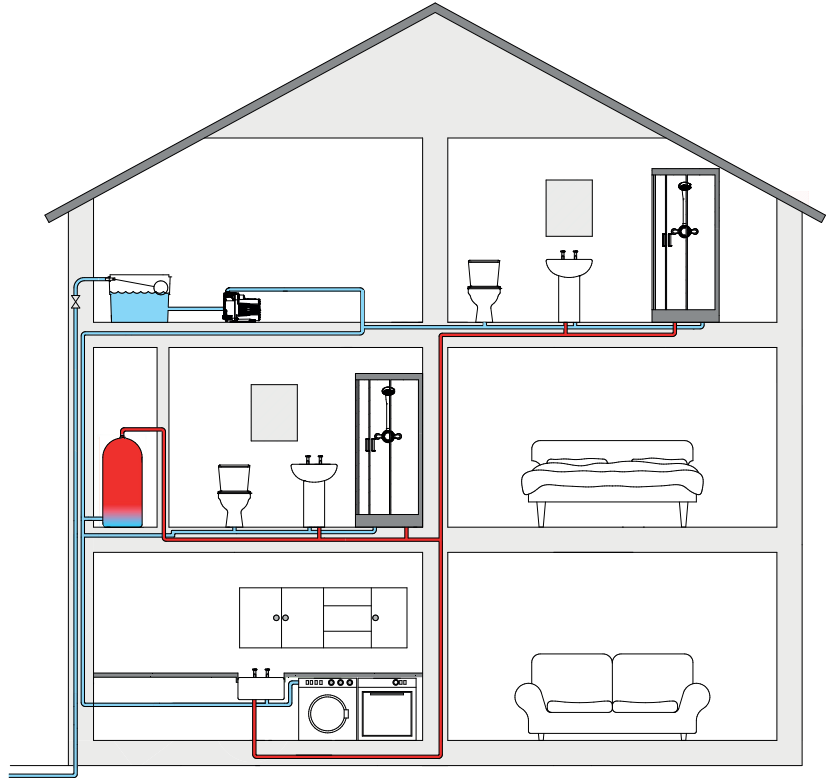
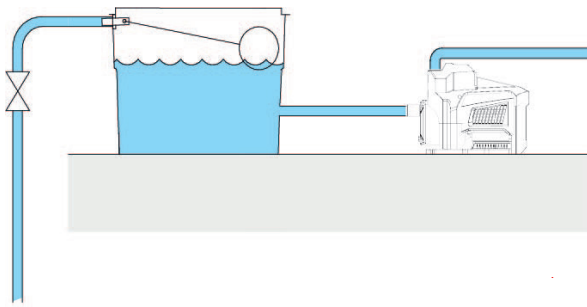

Boosting from an underground cold water storage tank

The Mainsboost VariQ pump is self-priming and can 'lift' water up to 6 metres from an underground cold water storage tank if required.

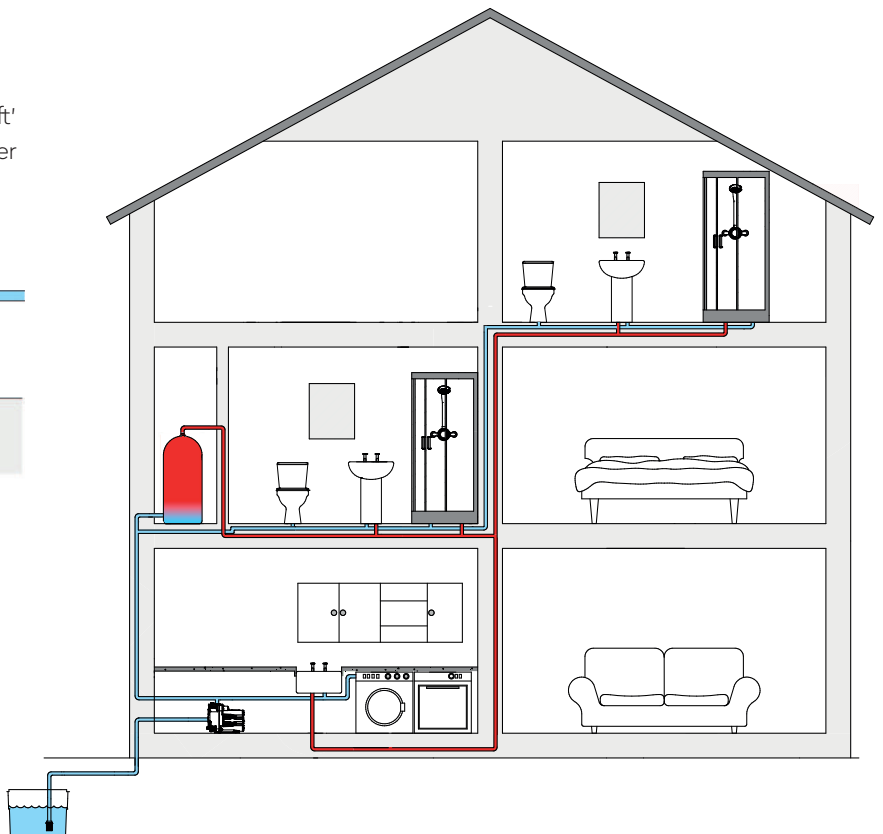
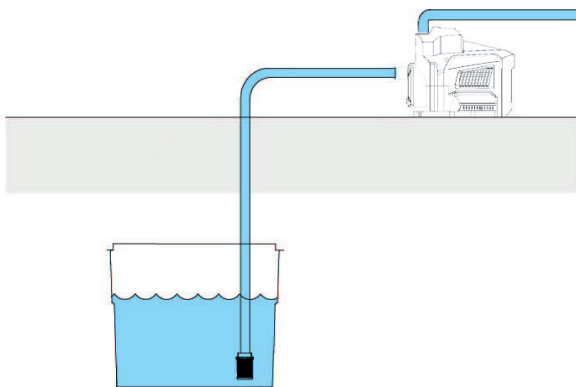











Mainsboost VariQ Applications

This application table is a general guide only and individual site conditions may vary. For advice or technical assistance, please contact [TechAssist on +44 \(0\) 0800 31 969 80](tel:+442080031969)

Mainsboost VariQ variable speed pump

1.5 bar	2.0 bar	2.5 bar	3.0 bar	3.5 bar
---------	---------	---------	---------	---------

Pressure boost	Medium		High		
	70 l/min	60 l/min	50 l/min	40 l/min	30 l/min
Maximum flow rate (at constant controlled pressure)	70 l/min	60 l/min	50 l/min	40 l/min	30 l/min
Boost whole house or apartment up to 3 bathrooms	●	●	●	●	●
Boost supply from cold water storage tank to combination boiler	●	●	●	●	●
Boost supply from cold water storage tank to pressurised hot water cylinder	●	●	●	●	●
Showers (standard shower head)	 x4	 x4	 x3	 x2	 x2
Showers (drench shower head)	 x3	 x3	 x2	 x2	 x1
Maximum number of outlets	10	10	10	10	10
Up to 1 floor	●	●	●	●	●
Up to 2 floors		●	●	●	●
Up to 3 floors			●	●	●
Maximum number of floors	1	Up to 2	Up to 3	Up to 3	Up to 3

Mainsboost VariQ Variable speed booster



Mainsboost VariQ

Suitable for multiple applications and designed for whole house use within domestic properties, the Mainsboost VariQ fully packaged water boosting pump offers variable speed pump control to constantly monitor water pressure at the point of use. This feature ensures that no matter how many outlets are opened at once, constant water pressure will be delivered without a drop in pressure or flow.

Part No	Model	Max Pressure	Max Flow
47322	VariQ	4.2 bar (44 m)	97 l/min
29044	Connection kit (UK)		
29045	Connection kit (ROI)		

Why not consider...

Stuart Water Conditioners feature an unique catalytic alloy core which effectively prevents hard lime-scale deposits from forming. Simply installed in-line with the existing pipework to protect all outlets and appliances within the home.

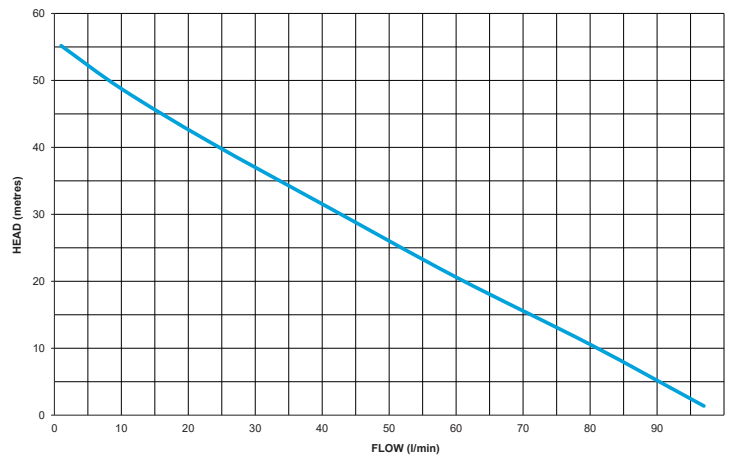

Dimensions

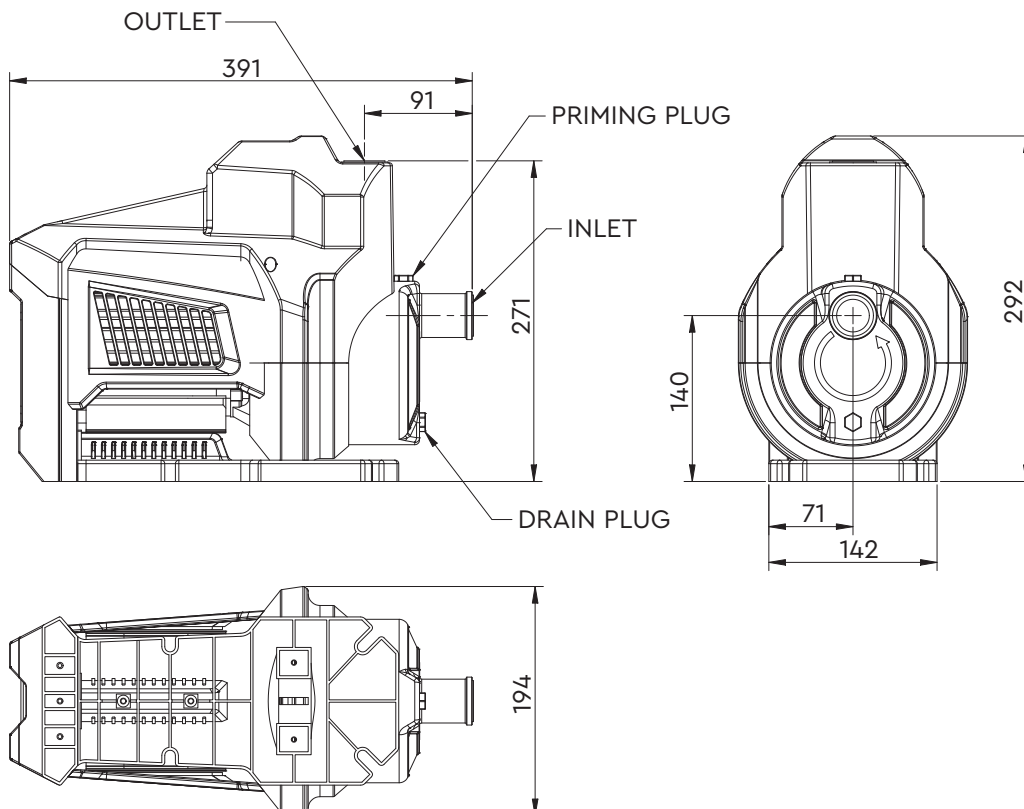

Mainsboost VariQ Technical specifications

		Mainsboost VariQ 47332
General	Warranty	2 years
	Approvals	CE / UKCA
Features	Pump type	Centrifugal Multistage
	Pump control	Pressure/Flow Switch
	Priming vent plug	✓
	Self priming	✓
	Non-return valve	✓
	Dry run protection	✓
	Typical noise	from 51 dB(A)
Performance	Maximum head – closed valve	5.5 bar (57 metres)
	Performance @ 40 ltrs/min	Up to 3.0 bar (30 metres)
	Performance @ 70 ltrs/min	Up to 1.5 bar (15 metres)
	Maximum flow	97 ltrs/min
	Minimum static inlet pressure	0.1 bar (1 metres)
	Maximum static inlet pressure	1.0 bar (10 metres)
	Maximum static outlet pressure	1.2 bar (12 metres)
	Maximum working pressure*	0.65 MPa (6.5 bar)
	Max. ambient air temperature	40 °C
	Min / Max water temperature	Min 4 °C / Max 23 °C
	Maximum suction lift**	4 metres
Materials	Pump body	Stainless Steel
	Impeller	Plastic
	Pump shaft	Stainless Steel 304
	Mechanical seal	Carbon / Ceramic / EDPM
Connections	Pump connections	G-1 Female
	Connection hose kits (optional)	G 1 M – 22mm push-fit, 300mm long x2 (UK) G 1 M – 21mm push-fit, 300mm long x2 (ROI) Integral isolation valves
Motor	Type	Permanent magnet variable frequency (thermally protected)
	Duty rating	Continuous (S1)
Electrical	Power supply (Vac/Ph/Hz)	220–240 V a.c. / 1 / 50–60 Hz
	Power consumption – P1	665 Watts
	Current – full load	2.9 Amps
	Fuse rating	5 Amps
	Power cable length	1.5 metres (pre-wired)
Physical	Enclosure protection	IPX4
	Length	391 mm
	Width	194 mm
	Height – excluding hoses	292 mm
	Weight – including fittings	9.0 Kg
* The maximum pressure that can be applied to the pump under any installation conditions.		
** A foot-valve and strainer is recommended if suction lift is required.		

Our brands Powering water for all applications

Stuart Turner offer a comprehensive range of solutions, specifically designed to suit a variety of applications in both domestic and commercial markets.

Invest in a name you can trust – quality, reliability, innovation and customer service.

AQUABOOST

Standard and bespoke booster sets

Why Aquaboost?

Aquaboost offers a comprehensive range of integrated pump and water storage solutions designed to optimise space. Supplied as a ready to install packaged product, they deliver improved performance from unvented water cylinders and combination boilers. Ideal for larger domestic, and commercial applications. The possibilities are endless.



MAINSBOOST

Mains water pressure boosting solutions

Why Mainsboost™?

Mainsboost™ Water Performance Systems are specifically designed to stabilise water pressure and dramatically improve water flow rates to all direct on mains appliances. They deliver improved performance from unvented water cylinders, combination boilers and high performance shower heads, allowing multiple outlets to run simultaneously.



MONSOON

Whole house, bathroom and shower pumps

Why Monsoon?

Monsoon is the benchmark for high performing, quality brass pumps available on the market. This comprehensive range is specifically designed to meet the demands of a host of domestic and light commercial applications in vented systems, from a single tap and shower to a complete bathroom or the whole property.

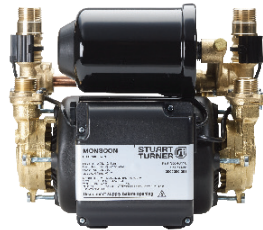

SHOWERMATE

Bathroom and shower pumps

Why Showermate?

Showermate offers a range of high quality plastic pumps providing an effective solution to boost the performance of a single tap, shower or complete bathroom. Showermate pumps are suitable for water pressure and flow boosting applications within properties featuring a vented plumbing system.



WASTEFL0

Why Wasteflo?

Wasteflo offers a variety of products to simply and efficiently remove waste water from your home or commercial building, allowing you to create a bathroom, wet room, kitchen or utility room anywhere a connection using gravity to the main soil/waste pipe is not possible.



STUART

Circulators, pressurisation units, heating products, water conditioners and pumps

Why Stuart?

The Stuart brand consists of a range of circulators, pressurisation units, heating related products, water conditioners and a diverse range of water pumps, along with associated accessories and controls. Every product has been designed to provide high levels of performance and reliability.



#POWERINGWATER



LIMESCALE PROBLEM? SORTED.

STUART WATER CONDITIONERS

Range of highly effective magnetic and catalytic water conditioners for domestic, commercial and industrial applications offer a solution to match the typical water flow from the cold water mains to the property and are simply installed in-line with the existing pipework. WRAS approved and completely maintenance free.

STUART-TURNER.CO.UK



#POWERINGWATER

Stuart Turner Ltd
Market Place
Henley-on-Thames
Oxfordshire
RG9 2AD
England

Telephone +44 (0) 1491 572655
Fax +44 (0) 1491 573704
E-mail info@stuart-turner.co.uk

www.stuart-turner.co.uk

VAT Reg No. 193 7627 68. Registered in England No. 88368
Registered Office: Market Place, Henley-on-Thames
Stuart Turner Ltd reserves the right to alter or change
specification without notice.

Part No: 47322
Issue No: 01

Follow us on Facebook, Twitter, Instagram and LinkedIn



#POWERINGWATER