

BG SERIES

SELF-PRIMING CENTRIFUGAL PUMPS

Close-coupled centrifugal pumps with built-in ejector system, designed to remain primed even in the presence of water-dissolved gases. The extensive use of pressed stainless steel ensures a high-performance, durable and lightweight pump.

- ❑ **"GARDEN" VERSION AVAILABLE WITH HANDLE, TERMINAL BOX WITH INCORPORATED SWITCH AND 2 m CABLE WITH PLUG**
- ❑ **EXTENSIVE USE OF AISI 304 OR AISI 316 STAINLESS STEEL**
- ❑ **IP 55 MOTOR PROTECTION**

APPLICATIONS

- Water handling for domestic use.
- Lawn sprinkling.
- Composition of surge tank units for pressure boosting in various applications.
- Washing and transfer.

SPECIFICATIONS

- **Delivery:** up to **70 l/min (4,2 m³/h).**
- **Head:** up to **53 m.**
- **Maximum operating pressure: 8 bar.**
- **Maximum total lift 8 m** (1¹/₄ suction pipe and foot valve for water at 20°C).
- **Continuous duty.**
- **Temperature of pumped liquid: -10°C to +40°C.**
- **Max ambient temperature: 40°C.**
- Enclosed motor with external ventilation and **aluminium alloy finned casing.**
- Versions:
 - Single-phase** 220-240 V 50 Hz, permanently connected capacitor and built-in automatic reset overload protection.
 - Three-phase** 220-240/380-415 V 50 Hz, thermal overload protection to be provided by user.
- Power up to 1.1 kW.
- Class **F Insulation.**
- **IP 55 protection.**



TABLE OF MATERIALS

PART	MATERIAL
Pump body, seal-housing, Impeller	STAINLESS STEEL (AISI 304 – DIN 1.4301)
Diffuser, Ejector	THERMOPLASTIC MATERIAL SUITABLE FOR HANDLING DRINKING WATER
Shaft extension	STAINLESS STEEL (AISI 316 – DIN 1.4571)
Fill and drain plugs	NICKEL-PLATED BRASS
Mechanical seal	CARBON/CERAMIC/NBR
O-ring seals	NBR

BG SERIES OPERATING CHARACTERISTICS AT 2850 rpm 50 Hz

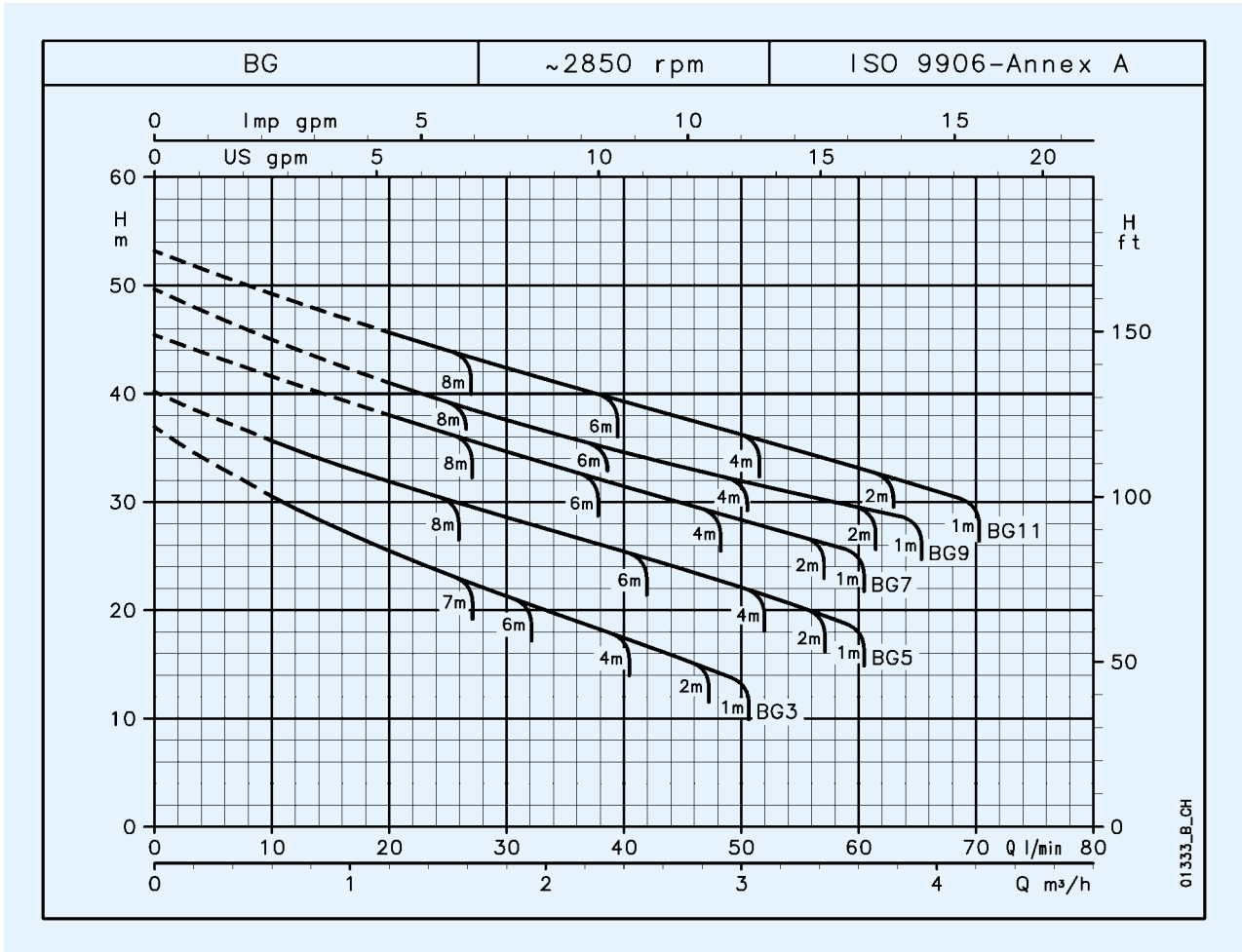

PUMP TYPE	RATED POWER		Q = DELIVERY								
			l/min	10	20	30	40	50	60	65	70
			m ³ /h	0.6	1.2	1.8	2.4	3	3.6	3.9	4.2
			H = TOTAL HEAD METERS COLUMN OF WATER								
BG(M)3	0.37	0.5	36.9	30.6	25.6	21.5	17.7	13.8			
BG(M)5	0.55	0.75	40.2	35.7	32.0	28.8	25.7	22.4	18.8		
BG(M)7	0.75	1	45.4		38.1	34.8	31.7	28.6	25.6		
BG(M)9	0.9	1.2	49.6		41.1	37.7	34.8	32.2	29.8	28.6	
BG(M)11	1.1	1.5	53.2		45.8	42.5	39.5	36.5	33.5	31.9	30.3

Maximum delivery depends on geodetic suction lift with clean 8 m pipe and 1 1/4" foot valve.

bg-2p50_a_th

These performances are valid for liquids with density $\rho = 1.0 \text{ kg/dm}^3$ and kinematic viscosity $\gamma = 1 \text{ mm}^2/\text{sec}$.

PUMP TYPE	INPUT POWER*	INPUT CURRENT*	CAPACITOR
SINGLE-PHASE	220-240 V		
	kW	A	$\mu\text{F} / 450 \text{ V}$
BGM3	0.67	2.96	14
BGM5	0.91	4.33	16
BGM7	1.11	5	20
BGM9	1.24	5.54	25
BGM11	1.43	6.47	30

PUMP TYPE	INPUT POWER*	INPUT CURRENT*	INPUT CURRENT*
THREE-PHASE	220-240 V		380-415 V
	kW	A	A
BG3	0.68	2.56	1.48
BG5	0.81	2.74	1.58
BG7	1.1	3.71	2.14
BG9	1.16	4.24	2.45
BG11	1.38	4.59	2.65

* Maximum value in specified range

bg-2p50_a_te

DIMENSIONS AND WEIGHTS, BG SERIES

BG

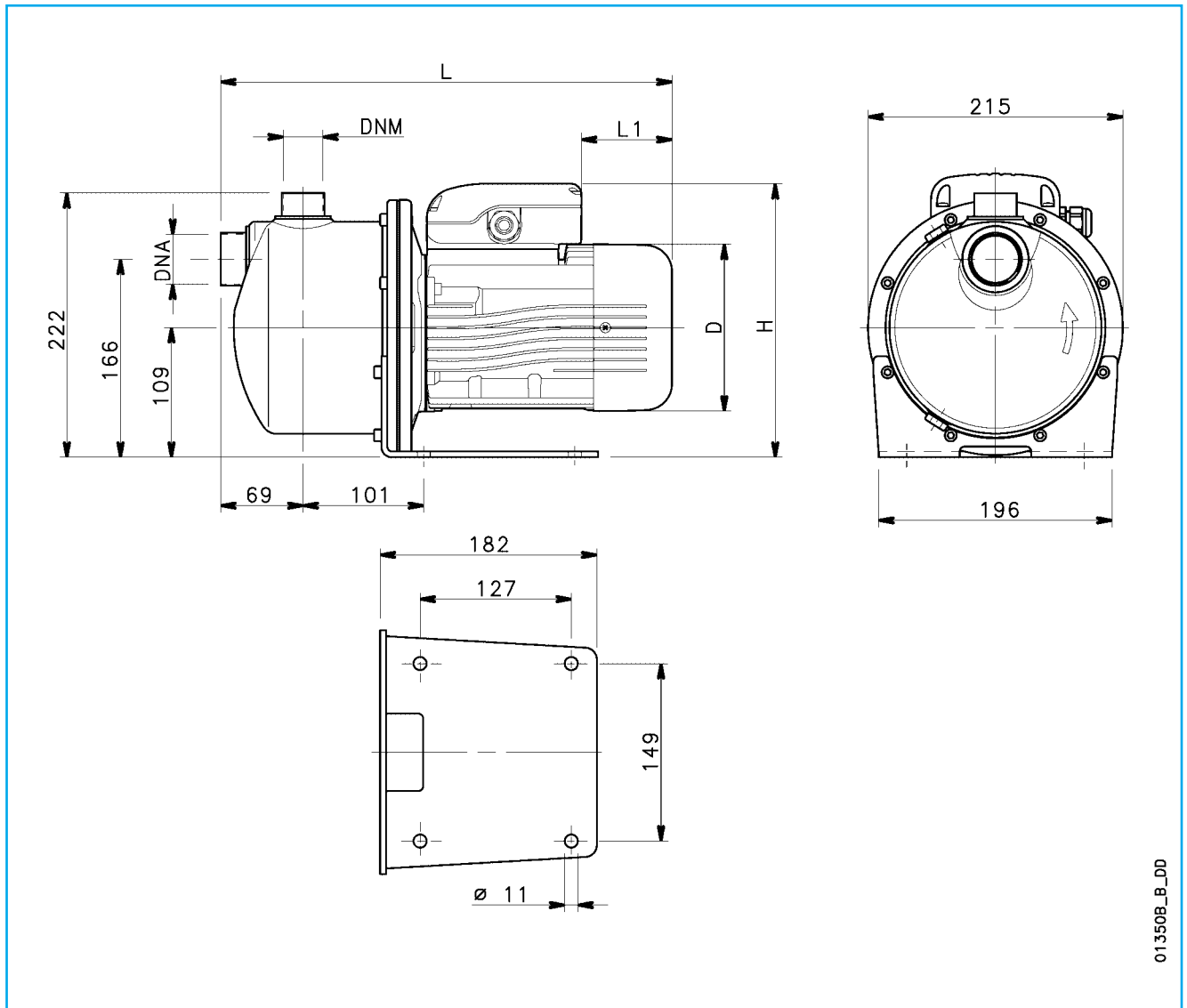

01350B_B_DD

PUMP TYPE	DIMENSIONS (mm)				DNA	DNM	WEIGHT
	D	L	L1	H			
BGM3	120	366	62	220	Rp 1¼	Rp 1	10
BGM5	140	380	76	230	Rp 1¼	Rp 1	12
BGM7	140	380	76	230	Rp 1¼	Rp 1	13
BGM9	140	380	31	239	Rp 1¼	Rp 1	13
BGM11	156	425	69	246	Rp 1¼	Rp 1	16
BG3	120	366	62	220	Rp 1¼	Rp 1	10
BG5	140	380	76	230	Rp 1¼	Rp 1	12
BG7	140	380	76	230	Rp 1¼	Rp 1	13
BG9	140	380	76	230	Rp 1¼	Rp 1	13
BG11	156	425	114	238	Rp 1¼	Rp 1	16

bg-2p50_a_td