

## NOCCHI JET

### ELECTRIC SELF-PRIMING PUMPS IN CAST IRON

RUGGED AND RESISTANT, SELF-PRIMING, HIGH SUCTION CAPACITY

The self-priming pumps in the JET range combine the advantages and practical features of centrifugal pumps with the functionality of self-priming pumps. The Venturi pipe system on these pumps guarantees optimal hydraulic performance and impressive suction capacity, maintaining priming even in the presence of air or gas bubbles trapped in the water.

#### MOTOR

- Closed, ventilated from exterior.
- Protection rating IP 44.
- Insulation class F.
- Single phase power supply with permanently activated capacitor and thermal cutout protection incorporated in the motor winding.
- Three phase power supply with external protection to be fitted by the user.
- Rotation speed 2850 rpm.
- Continuous duty.

#### APPLICATIONS

- Lifting and distribution of water in domestic systems, with continuous or intermittent duty.
- Pressure booster systems.
- Washing, irrigation of vegetable gardens, supply to fountains, transfers.
- Lifting from wells or cisterns.

#### APPLICATION DATA

- Type of liquid: clean water without suspended solid bodies or abrasive material.
- Maximum liquid temperature: 50°C.
- Maximum recommended suction height: 8 m with foot valve.
- Maximum operating pressure: 6 bar. ( 10 bar for mod. 100 - 160 )



#### TABLE OF MATERIALS

Component	Material	
	NEW JET	JET
1 Pump body	Cast iron EN GJL 200 (ex G20)	Cast iron EN GJL 200 (ex G20)
2 Motor bracket	Aluminum	Cast iron EN GJL 200 (ex G20)
3 Impellers	Technopolymer with shim ring in stainless steel X5 CrNi 1810 (AISI 304 )	Technopolymer models 600-800-1000
		Molded brass alloy models 100-160-800-1000
4 Diffuser-Venturi pipe nozzle	Monobloc unit Technopolymer	Technopolymer
5 Motor shaft	Stainless steel X 12 CrNiS 1809 (AISI 416)	Stainless steel X 12 CrNiS 1809(AISI 416)
6 Mechanical gasket	Graphite	Graphite
7 Counterface	Ceramic	Ceramic
8 Seals	NBR 70 shore	NBR 70 shore

# NOCCHI JET

## SELF-PRIMING PUMPS IN CAST IRON

### HYDRAULIC PERFORMANCE

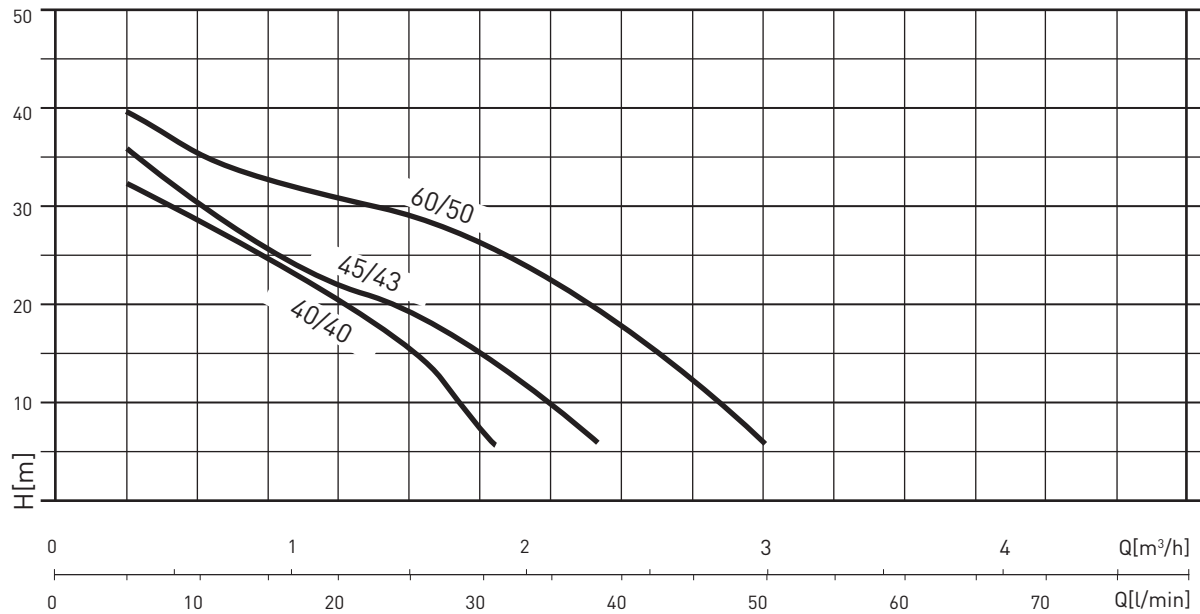

### PERFORMANCE TABLE

MODEL	Motor output (P2)		Motor output (P1)		VOLT	In (A)	μF	Q	L/min	0	10	20	30	40	50	
	HP	kW	HP	kW					m³/h	0	0.6	1.2	1.8	2.4	3	
NEWJET 40/40 M	0.5	0.37	0.8	0.6	1 - 220 - 240 V	3	6	m.c.a. / m.w.c.	41	28	21	8				
NEWJET 45/43 M	0.5	0.37	0.8	0.6	1 - 220 - 240 V	3	8		43	30	23	16	1			
NEWJET 60/50 M	0.75	0.35	1.1	0.8	1 - 220 - 240 V	4	12.5		43	36	31	26	18	6		

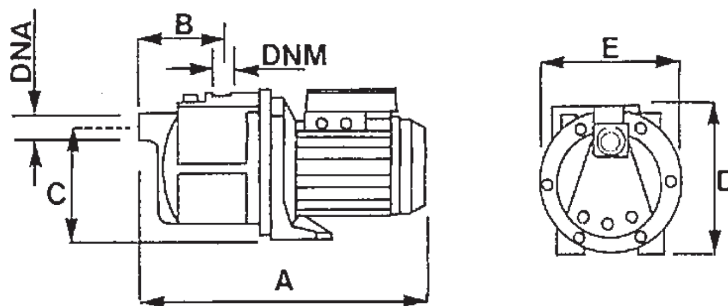

### OVERALL DIMENSIONS AND WEIGHTS

MODEL	Dimensions (mm)							Weight (kg)
	A	B	C	D	E	DNA	DNM	
NEWJET 40/40	351	93	130	180	174	1"	1"	8.2
NEWJET 45/43	351	93	130	180	174	1"	1"	8.2
NEWJET 60/50	351	93	130	180	174	1"	1"	9

# NOCCHI JET

## SELF-PRIMING PUMPS IN CAST IRON

### HYDRAULIC PERFORMANCE

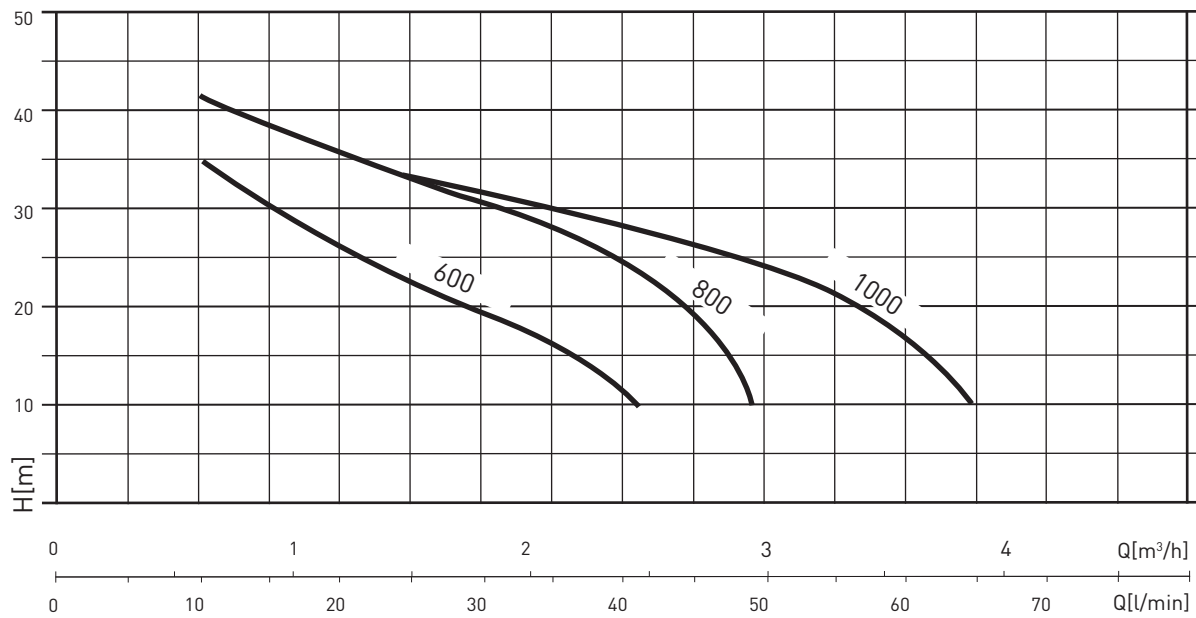

### PERFORMANCE TABLE

MODEL	Motor output (P2)		Motor output (P1)		VOLT	In (A)	μF	Q	L/min m³/h	5	20	30	40	50	60	70	
	HP	kW	HP	kW						0.3	1.2	1.8	2.4	3	3.6	4.2	
JET 600 M JET 600 T	0.8	0.6	0.9	0.7	1 ~ 220 - 240 V 3 ~ 230 - 400 V	3.2 1.9-1.1	8	m.c.a. / m.w.c.	38	25	20	11					
JET 800 M JET 800 T	1	0.75	1.3	1	1 ~ 220 - 240 V 3 ~ 230 - 400 V	4.5 3.6-2.1	12.5		44	36	31	27	7				
JET 1000 M JET 1000 T	1.36	1	1.5	1.1	1 ~ 220 - 240 V 3 ~ 230 - 400 V	5 3.8-2.2	16		45	36	32	28	25	15	3		

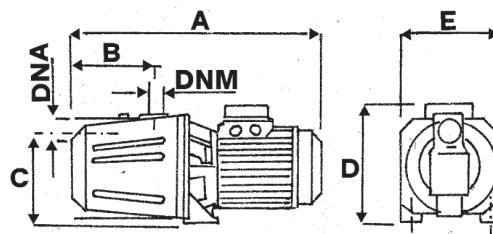

### OVERALL DIMENSIONS AND WEIGHTS

MODEL	Dimensions (mm)							Weight (kg)
	A	B	C	D	E	DNA	DNM	
JET 600	400	147	160	190	182	1"	1"	13.7
JET 800	400	147	160	190	182	1"	1"	14.2
JET 1000	425	147	160	190	182	1"	1"	16.8

# NOCCHI JET

## SELF-PRIMING PUMPS IN CAST IRON

### HYDRAULIC PERFORMANCE

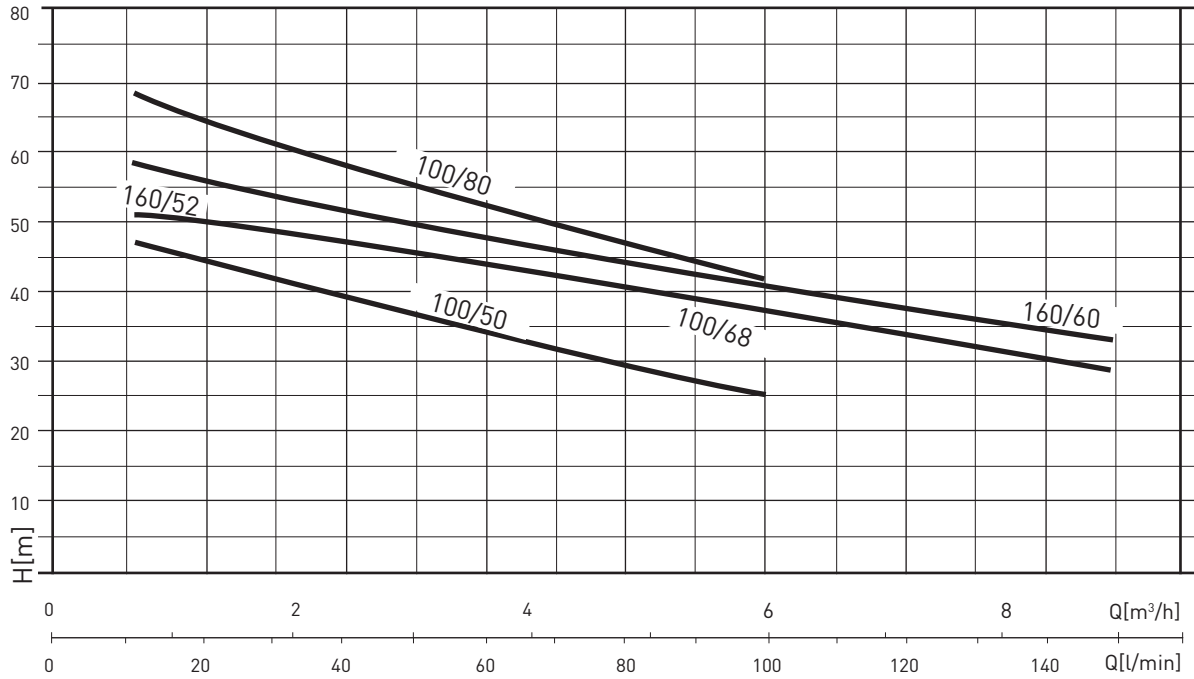

### PERFORMANCE TABLE

MODEL	Motor output (P2)		Motor output (P1)		VOLT	I <sub>n</sub> (A)	μF	Q	L/min	5	20	40	60	80	100	130	160	
	HP	kW	HP	kW						m.c.a. / m.w.c.	0.3	1.2	2.4	3.6	4.8	6	7.8	9.6
JET 100/50 M JET 100/50 T	1.5	1.1	2.2 2.4	1.7 1.8	1 ~ 230 V 3 ~ 230 - 400 V	8.1 5.5-3.2	35	m.c.a. / m.w.c.	50	45	40	35	31	27				
JET 100/68 M JET 100/68 T	2	1.5	2.8 2.4	2.1 2.8	1 ~ 230 V 3 ~ 230 - 400 V	9.8 5.5-3.2	40		60	55.5	49	47.5	34.5	30.5				
JET 100/80 T	3	2.2	3.5	2.6	3 ~ 230 - 400 V	8.1-4.7			70	64.3	58	51.5	46.5	42				
JET 160/52 M JET 160/52 T	2	1.5	3.1 2.8	2.3 2.1	1 ~ 230 V 3 ~ 230 - 400 V	10.5 6.9-4.0	40		52	49.5	48	45	42	38.7	33.2	27		
JET 160/60 T	3	2.2	3.5	2.6	3 ~ 230 - 400 V	8.1-4.7			59	55.6	53	47	43.4	40	36	32.5		

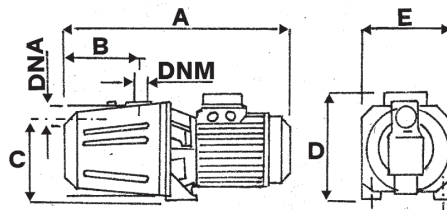

### OVERALL DIMENSIONS AND WEIGHTS

MODEL	Dimensions (mm)										Weight (kg)
	A	B	C	D	E	F	H1	H2	DNA	DNM	
JET 100/50	177.5	157	495	220	180	247	170	223	1" 1/2	1"	26
JET 100/68 - 160/52	177.5	157	508	220	180	247	170	223	1" 1/2	1"	27
JET 100/80 - 160/60	177.5	157	508	220	180	229	170	223	1" 1/2	1"	28