

EVOPLUS SMALL / EVOPLUS SMALL SAN

WET ROTOR ELECTRONIC CIRCULATORS

SELECTION TABLE - EVOPLUS SMALL

MODEL	Q=m ³ h	0	2,4	3	4,2	5,4	7,2	9,6
	Q=l/min	0	40	50	70	90	120	160
EVOPLUS 40/180 M	H (m)	4,2	4,2	4	3,1	2,4		
EVOPLUS 60/180 M		6,1	6,1	5,8	4,6	3,4		
EVOPLUS 80/180 M		8,2	8,2	7,7	6,2	4,8	2,9	
EVOPLUS 110/180 M		11,1	10,1	9,2	7,5	5,9	3,9	
EVOPLUS 40/180 XM		4,1	4,1	4	3,1	2,2		
EVOPLUS 60/180 XM		6,1	6,1	5,7	4,5	3,4		
EVOPLUS 80/180 XM		8,1	8,1	7,6	6,2	4,9	3	
EVOPLUS 110/180 XM		11,3	10,2	9,5	7,9	6,3	4,3	2
EVOPLUS B 40/220.32 M		4,2	4,2	4,2	3,3	2,5	1,3	
EVOPLUS B 60/220.32 M		6,1	6,1	5,6	4,6	3,6	2,2	
EVOPLUS B 80/220.32 M		8	8	7,3	6	4,9	3,3	
EVOPLUS B 110/220.32 M		11,2	10,5	9,6	8,1	6,8	5	2,6
EVOPLUS B 40/250.40 M		4,2	4,2	4,2	3,3	2,5	1,3	
EVOPLUS B 60/250.40 M		6,1	6,1	5,6	4,6	3,6	2,2	
EVOPLUS B 80/250.40 M		8	8	7,3	6	4,9	3,3	
EVOPLUS B 110/250.40 M		11,2	10,5	9,6	8,1	6,8	5	2,6
EVOPLUS D 40/220.32 M		4,2	4,2	4,2	3,3	2,5	1,3	
EVOPLUS D 60/220.32 M		6,1	6,1	5,6	4,6	3,6	2,2	
EVOPLUS D 80/220.32 M		8	8	7,3	6	4,9	3,3	
EVOPLUS D 110/220.32 M		11,2	10,5	9,6	8,1	6,8	5	2,6
EVOPLUS D 40/250.40 M		4,2	4,2	4,2	3,3	2,5	1,3	
EVOPLUS D 60/250.40 M		6,1	6,1	5,6	4,6	3,6	2,2	
EVOPLUS D 80/250.40 M		8	8	7,3	6	4,9	3,3	
EVOPLUS D 110/250.40 M		11,2	10,5	9,6	8,1	6,8	5	2,6

SELECTION TABLE - EVOPLUS SMALL SAN

MODEL	Q=m ³ h	0	2,4	3	4,2	5,4	7,2	9,6
	Q=l/min	0	40	50	70	90	120	160
EVOPLUS 40/180 SAN M	H (m)	4,2	4,2	4	3,1	2,4		
EVOPLUS 60/180 SAN M		6,1	6,1	5,8	4,6	3,4		
EVOPLUS 80/180 SAN M		8,2	8,2	7,7	6,2	4,8	2,9	
EVOPLUS 110/180 SAN M		11,1	10,1	9,2	7,5	5,9	3,9	
EVOPLUS B 40/220.32 SAN M		4,2	4,2	4,2	3,3	2,5	1,3	
EVOPLUS B 60/220.32 SAN M		6,1	6,1	5,6	4,6	3,6	2,2	
EVOPLUS B 80/220.32 SAN M		8	8	7,3	6	4,9	3,3	
EVOPLUS B 110/220.32 SAN M		11,2	10,5	9,6	8,1	6,8	5	2,6
EVOPLUS B 40/250.40 SAN M		4,2	4,2	4,2	3,3	2,5	1,3	
EVOPLUS B 60/250.40 SAN M		6,1	6,1	5,6	4,6	3,6	2,2	
EVOPLUS B 80/250.40 SAN M		8	8	7,3	6	4,9	3,3	
EVOPLUS B 110/250.40 SAN M		11,2	10,5	9,6	8,1	6,8	5	2,6

EVOPLUS SMALL / EVOPLUS SMALL SAN

WET ROTOR ELECTRONIC CIRCULATORS



compliant with the 2013
and 2015 european directive
ErP 2009/125/EC (ex EuP)

TECHNICAL DATA

Operating range: 2 to 12 m³/h with head up to 11 meters;

Liquid temperature range: from -10 °C to +110 °C.

Pumped liquid: clean, free of solid contaminants and mineral oils, non-viscous, chemically neutral, close to the properties of water. (max. glycol contents 30%).

Maximum working pressure: 16 bars (1600 kPa)

Standard flanging: DN 32, DN 40 PN 6 / PN 10 / PN 16 (4 slots)

Maximum ambient temperature: +40°C.

Minimum suction pressure: the values are given in the relevant tables.

Accessories: ½"F, ¾"F, 1"F, 1"¼F, 1"¼M unions DN 32 PN 6 and DN 40 PN 10 threaded counter flanges.

Electromagnetic compatibility: EVOPLUS circulators comply with standard EN 61800-3, in category C2, in terms of electromagnetic compatibility.

Electromagnetic emissions: Residential environment (containment measures may be necessary in certain cases).

Conducted emissions: Residential environment (containment measures may be necessary in certain cases).

APPLICATIONS

EVOPLUS electronic circulators can be used in heating, ventilation, and air conditioning systems for residential and commercial buildings including:

- Large residential buildings
- Clinics and Hospitals
- Real Estate Assets
- Condominiums and apartment blocks
- Schools
- Homes
- Office buildings

Single version is available with threaded ports from 1 ½" and 2" and flanged DN 32, DN 40, PN 6 / PN 10 / PN 16.

The twin version is available with flanged pump body DN 32 and DN 40, PN 6 / PN 10 / PN 16.

Special version with bronze pump body for sanitary water circulation.

Compatible for external signal 0.10 v or PWM and for communication between devices Modbus with dedicated optional Multifunction module (standard equipment for twin version).

APPLICATIONS IN HEATING

The heating required in various applications changes significantly during the day/night due to the ambient temperature and changing occupancy levels. This situation is compounded by the different requirements of the various rooms and opening or closing of the various circuit branches in complex installations. Electronically controlled wet rotor pumps constantly ensure, in almost all correctly sized installations, sufficient power and, simultaneously, lower noise emissions, greater comfort and a significant reduction in running costs.

APPLICATIONS IN AIR CONDITIONING

Unlike conventional electronic pumps, EVOPLUS electronic circulators can also be used in air conditioning systems where the temperature of the liquid pumped is lower than the ambient temperature. In these conditions condensate tends to form on the outer surface of the circulator although this does not impair proper operation of either the electronic or mechanical sections. The unit is designed and sized in such a way as to allow the condensate to drain without damaging the construction components.

APPLICATIONS FOR HOT WATER CIRCULATION

The SAN version pump with bronze body has been developed specifically for the circulation of secondary hot water. The constant temperature operating mode controls the water temperature in the circulation pipe without needing to use thermostatic valves, thus maintaining required water temperature for user.

CONSTRUCTION FEATURES

Enbloc circulator composed of cast iron hydraulic section and wet rotor synchronous motor. Motor casing in aluminium. Scroll type pump body featuring high hydraulic efficiency thanks to highly precise design and smooth internal surfaces. In-line suction and discharge ports. The single version is supplied as standard with insulating covers to avoid heat loss and/or the formation of condensate on the pump body. Insulation of the twin version is to be provided by the installer. Use special caution to avoid obstructing the condensate drainage labyrinths in order to avoid impairing operation.

EVOPLUS circulators for small community systems are connected to the power supply line by means of a convenient connector with relative plug supplied as standard that makes the operation simple and fast.

Impeller in technopolymer, motor shaft in alumina held in graphite bearings lubricated by the pumping medium. Rotor protective jacket in stainless steel. Ceramic thrust ring, ethylene propylene seals and stator jacket in carbon fiber composite. Permanent magnet synchronous motor. The twin version features an automatic swing check valve incorporated in the discharge port to avoid water recirculating through the unit when it is not running; moreover, a blank flange is supplied as standard to allow either of the two motors to be removed for servicing. Standard execution of the pump body is PN 16; the flanged version features 4 slots compatible with PN 6 / PN 10 / PN 16 counter-flanges for interchangeability of pumps in existing systems.

Circulator protection rate: IP 44

Insulation Class: F

Standard voltage: single-phase 220/240 V, 50/60Hz

Sound pressure level ≤33 dB(A)

This product complies with European standards EN 61800-3 – EN 60335-1 – EN 60335-2-51

EVOPLUS SMALL / EVOPLUS SMALL SAN

WET ROTOR ELECTRONIC CIRCULATORS

EVOPLUS CONSTRUCTION FEATURES FOR SMALL COMMUNITY SYSTEMS (ELECTRONIC DEVICE)

EVOPLUS circulators are controlled by means of an IGBT-based device in NPT-technology of the latest generation for higher efficiency and robustness. Specific features includes:

- Sensorless motor control
- Sine wave modulated PWM
- High carrier frequency to eliminate all audio band noise
- Dedicated 32-bit Processor
- Optimised space vector algorithm

An intuitive and functional user interface ensures ease of calibration for all users. The easy to read OLED display on the control panel, 4 easy navigation keys, a drop down menu in line with the latest trends in the field of mobile telephony and a very wide range of functions mean that EVOPLUS circulators are truly revolutionary products. A reliable and robust construction combined with a modern and innovative design completes the product also from an aesthetic point of view.

This range is prearranged for operation with the remote controls having the following expansion modules:

BASIC MODULE

- Economy Function
- Circulator Start/stop
- Alarms system availability
- Indication pump running

MULTIFUNCTION MODULE *

- 2 analogue signals 0-10V
- 1 PWM signal
- 1 analogue signal ΔT from temperature sensor
- Connection to ModBus control systems.
Optional Lonbus with relative module.
- Alarms system availability
- Indication pump running

* Available input when the associated operation is activated

TECHNICAL DATA

N°	PARTS	MATERIAL
1	PUMP BODY	CAST IRON 250 UNI ISO 185 - CTF BRONZE (for SAN version)
4	IMPELLER	TECHNOPOLYMER
7A	MOTOR SHAFT	ALUMINA
7B	ROTOR	STAINLESS JACKET
8	STATOR	-
10	MOTOR HOUSING	DIE CAST ALLUMINIUM
127	O-RING	RUBBER EPDM
128	STATOR SLEEVE	STAINLESS STEEL
130	CLOSING FLANGE	STAINLESS STEEL
131	THRUST RING SUPPORT	RUBBER EPDM
132	BUSHINGS	GRAPHITE

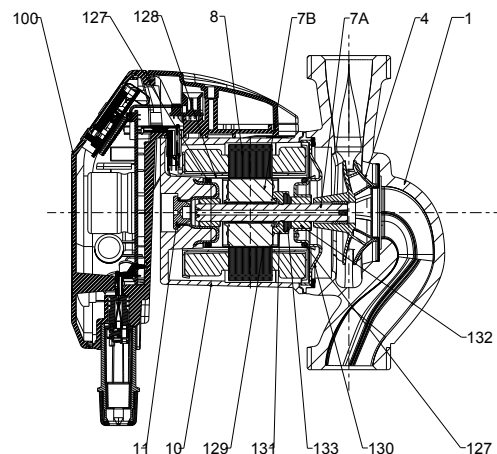

DESIGNATION INDEX:

(Example)

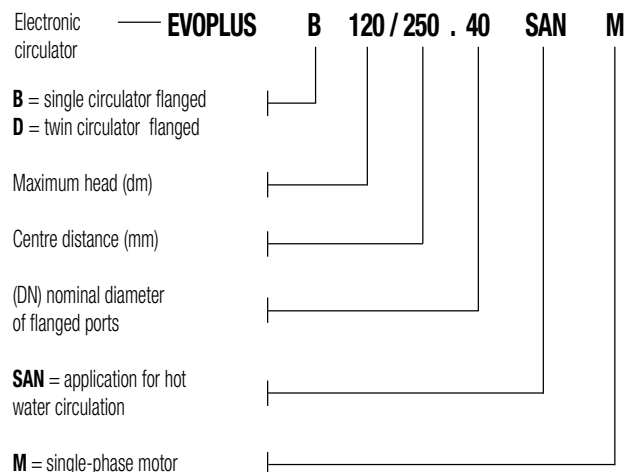
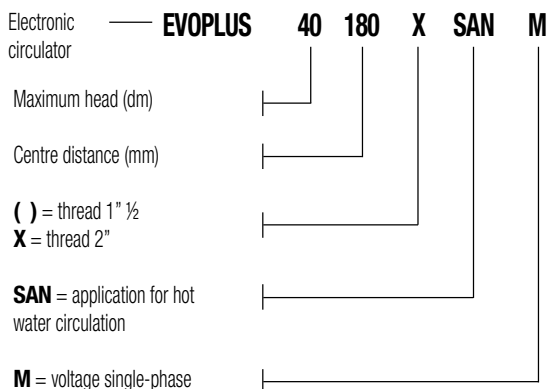

EVOPLUS SMALL / EVOPLUS SMALL SAN

WET ROTOR ELECTRONIC CIRCULATORS

OPERATING MODES

All functions listed below can be consulted by all users (irrespective of the level of expertise) simply by scrolling through the EVOPLUS menu. Calibration and parameter editing are protected and reserved for expert users. The EVOPLUS range is factory-set to the control mode with differential pressure proportional to the curve that guarantees the best energy efficiency index (EEI).

1 - $\Delta P-v$ proportional differential pressure control mode

Control mode $\Delta P-v$ provides linear variation of the head delivery value from H_{setp} to $H_{setp}/2$ in accordance with changes in flow rate.

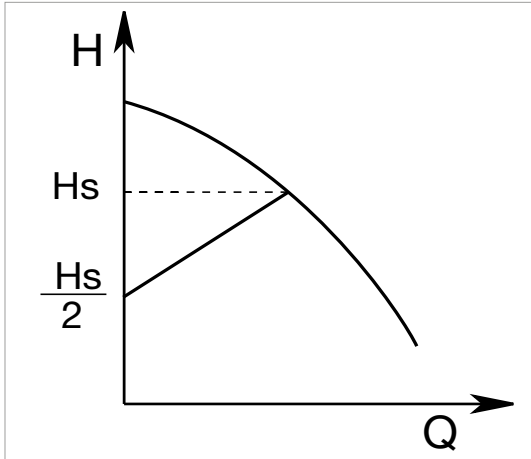

This control mode is particularly useful in the following types of installations:

a. two-pipe central heating systems with thermostatic valves and with:

- head of more than 4 metres;
- very long circuit piping;
- valves with broad operating range;
- differential pressure regulators;
- high pressure drops in sections of the system carrying the entirety of the water flow rate;
- low differential temperature.

b. Under-floor central heating systems and systems with thermo static valves and significant pressure drops in the boiler circuit.

c. Installations having primary circuit pumps with high pressure drops

Examples of set-point input with $\Delta P-v$

The following operating point is required:

$$Q = 6,5 \text{ m}^3/\text{h}$$

$$H = 6 \text{ m}$$

PROCEDURE:

1. In the graph, find the required operating point and then find the nearest EVOPLUS curve to it (in this case the point lies precisely on the curve)
2. Follow the curve until intersecting the circulator limit curve.
3. The head reading found at this limit point will be the set-point head to be entered to obtain the required operating point.

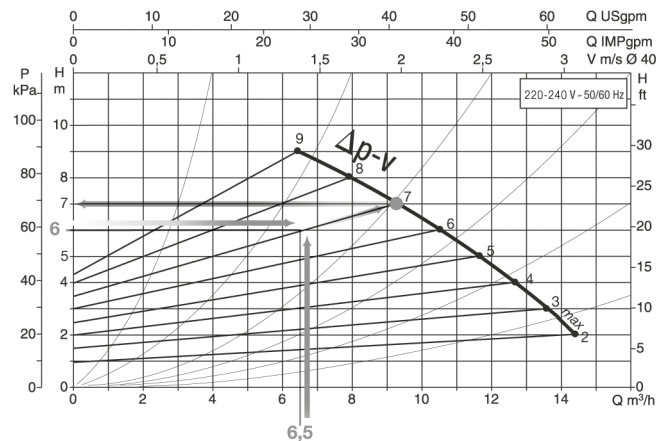

2 - $\Delta P-c$ constant differential pressure control mode

Control mode $\Delta P-c$ keeps system differential pressure constant at the user-settable value of H_{setp} despite changes in flow rate.

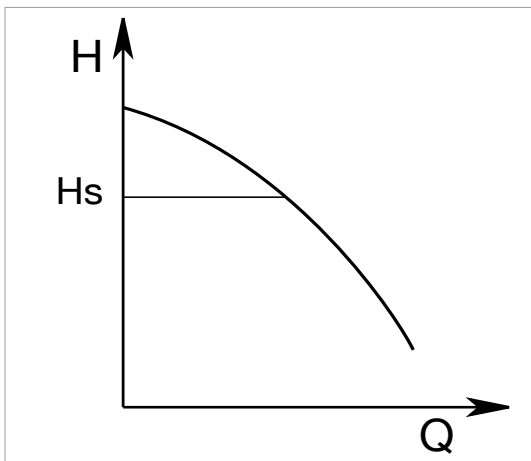

This control mode is particularly useful in the following types of installations:

a. two-pipe central heating systems with thermostatic valves and with:

- head of less than 2 metres;
- natural circulation;
- low pressure drops in sections of the system carrying the entirety of the water flow rate;
- high differential temperature (central heating).

b. Under-floor central heating systems with thermostatic valves

c. Single-pipe central heating systems with thermostatic valves and calibration valves

c. Installations having primary circuit pumps with low pressure drops

EVOPLUS SMALL / EVOPLUS SMALL SAN

WET ROTOR ELECTRONIC CIRCULATORS

3 - Constant curve control mode

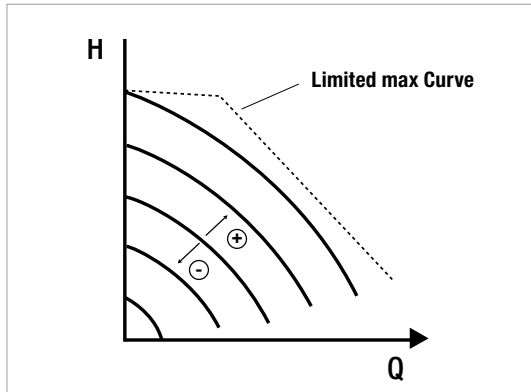

This control setting shows the curve of the circulator at constant speed. The operation curve is selected by setting the rotation speed on a percentage factor. Reaching 100% indicates the curve maximum. The speed of rotation may depend on power restriction and difference in pressure subject to model of circulator. The rotation speed can be set from the display or from an external signal 0-10V or PWM using the multifunction module.

The control setting is ideal for heating and air conditioning applications that require constant flow.

4 - Constant and proportional differential pressure control mode depending on water temperature. (Function can be activated with multifunction module)

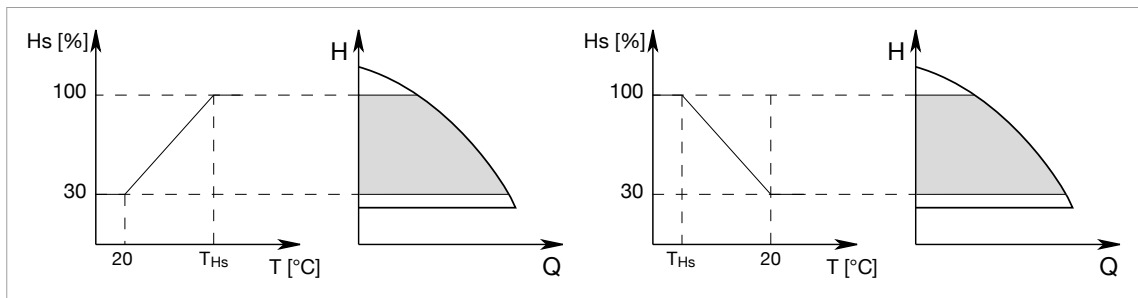

The circulator head set-point is reduced in accordance with the water temperature.

Liquid temperature can be set from 0°C to 100°C.

This control mode is particularly useful in the following types of installations:

- in variable flow rate installations (two-pipe central heating systems), in which a further reduction of circulator performance is provided in accordance with lowering of the circulating liquid temperature, in the presence of reduced heating demand.
- in constant flow rate installations (single-pipe and under-floor central heating systems), where the performance of the circulator can be adjusted only by activating the temperature influence function.

This function is set on EVOPLUS control panel.

5 - ΔT -c constant differential temperature control mode (Function can be activated with multifunction module) *

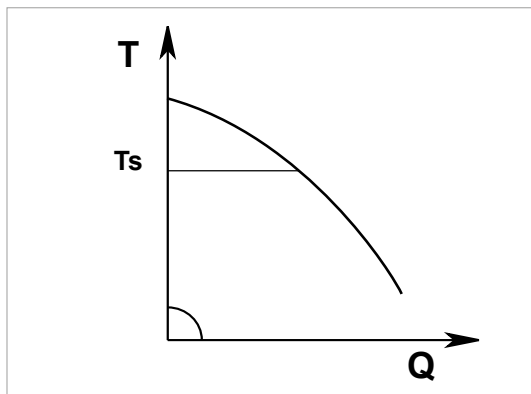

ΔT -c control mode keeps the differential temperature of the pumped liquid constant, changing the flow rate to the user-settable value T_{setp} .

(Function can be activated with multifunction module)

This control mode is particularly useful in the following types of installations :

- Under-floor central heating systems
- Installations having primary circuit pumps
- Installations having circuit pumps with heat exchanger
- Solar energy systems with storage tanks
- Swimming pool heating systems with solar panels

* Operation mode in development progress

ECONOMY FUNCTION

The economy function can be set directly on the control panel, by setting a reduction value (f.rid) the maximum value of which is 50%.

In all settings listed above the Hset value must be replaced with a Hset x f.rid value

EVOPLUS SMALL / EVOPLUS SMALL SAN

WET ROTOR ELECTRONIC CIRCULATORS

EVOPLUS MENU CONFIGURATIONS

The settings are made when passing from one page to another, in the circulator configuration menu.

The main settings of the system are graphically summed up on the Home Page.

The icon at top left indicates the type of regulation selected.

The icon at centre top indicates the operating mode selected (auto or economy).

The icon at top right indicates the presence of a single ① or twin inverter ②/①.

The rotation of the icon ① or ② indicates which circulation pump is operating.

At the centre of the Home Page is a read-only parameter which can be chosen from a small set of parameters on Page 9.0 of the menu.

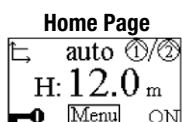

From the **Home Page** it is possible to access the page for **regulating the contrast** of the display: hold down the hidden button, then press and release the right button.

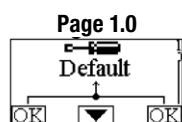



EVOPLUS SMALL circulators offer a **user menu** accessible from the Home Page by pressing and releasing the central "Menu" button.

The factory settings are set from **Page 1.0** by holding down the left and right buttons at the same time for 3 seconds.

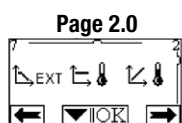
The resetting of the factory settings will be notified by the appearance of the symbol  next to the word "Default".



The regulating mode is set from **Page 2.0**. You can choose between the following modes:

1.  = Proportional differential pressure regulation.
2.  = Regulation with constant differential pressure.
3.  = Regulation with constant curve with rotation speed set from the display.

Page 2.0 displays 3 icons which represent:

central icon = setting currently selected

right icon = next setting

left icon = previous setting

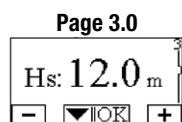

The regulating set-point can be modified from **Page 3.0**.

Depending on the type of regulation chosen on the previous page, the set-point to be set will be a head or, in the case of a Constant Curve, a percentage of the rotation speed.

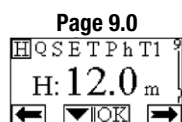

On **Page 9.0** it is possible to choose the parameter to be displayed on the Home Page:

H : Measured head expressed in metres

Q : Estimated flow rate expressed in m³/h

S : Rotation speed expressed in revs per minute (rpm)

E : Not present

P : Power distributed expressed in W

h : Operating hours

T : Not present

T1 : Not present

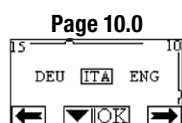

On **Page 10.0** you can choose the language in which to display the messages.

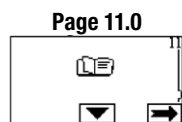

On **Page 11.0** you can display the alarms log by pressing the right button.

If the system finds any faults it records them permanently in the alarms log (up to a maximum of 15 alarms). For each recorded alarm a page composed of 3 parts is displayed: an alphanumeric code that identifies the type of fault, a symbol that illustrates the fault in graphic mode, and a message in the language selected on Page 10.0, giving a brief description of the fault.



By pressing the right button you can scroll through all the pages of the log.

2 questions appear at the end of the log:

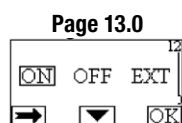

1. **"Reset Alarms?"** - Pressing OK (left button) resets any alarms still present in the system.

2. **"Delete Alarms Log?"** - Pressing OK (left button) deletes the alarms memorised in the log.

On page 13.0 you can set the system status in ON or OFF.

If ON is selected the pump is always on.

If OFF is selected the pump is always off.

EVOPLUS SMALL / EVOPLUS SMALL SAN

WET ROTOR ELECTRONIC CIRCULATORS

DESCRIPTION OF SYMBOLS DISPLAYABLE QUANTITIES

Symbol	Description
H Q S E T P h T1	Shows parameters
H	Head in metres
Q	Flow rate in m ³ /h Q < Q _{min} when Q is less than 30% of Q _{max} Q = 0 only when the Evoplus is switched off.
S	Speed in revs/minute (rpm)
E	Analog input 0-10V or PWM (with multi-function module)
T	Liquid temperature in °C – input D (with multi-function module and temperature sensor)
P	Power in kW
h	Working hours
T1	Liquid temperature in °C – input C (with multi-function module and temperature sensor)
T _{Hs}	Maximum liquid temperature in °C depending on regulation (with multi-function module and temperature sensor)

CIRCULATOR STATUS

Symbol	Description
①	Single circulator or nr. 1
②	Circulator nr. 2
②/①	Alternate twin circulators
②+①	Principal/reserve twin circulators (24 hours one motor / 24 hours the other motor)
②+①	Simultaneous twin circulators
ON	Circulator on
OFF	Circulator off
EXT	Circulator controlled by remote signal (ref. terminals 1-2)

TYPE OF OPERATION

Symbol	Description
auto	Auto function
Ⓔ	Economy function

TYPES OF CONTROL MODE

Symbol	Description
	Δp-c control mode (constant pressure)
	Δp-c control mode depending on temperature (in development progress)
	Δp-v control mode (variable pressure)
	Δp-v control mode depending on temperature (in development progress)
	Servomotor control mode with speed set on the display.
	Servomotor control mode with speed set by remote signal 0-10V
ΔT-c	ΔT-c control mode (constant temperature)

VARIOUS

Symbol	Description
	Control panel blocked
	Multifunction key for confirming parameters and scrolling pages













FACTORY SETTINGS

Parameter	Value
Control mode	Display of parameters
Hs (Differential Pressure Set-point)	
Fs (Frequency Set-point)	auto
Set-point percentage reduction	50 %
Twin operating mode	②/① = Alternating every 24h
Pump start control	EXT (from remote signal on input I1)











EVOPLUS SMALL / EVOPLUS SMALL SAN

WET ROTOR ELECTRONIC CIRCULATORS

TYPES OF ALARMS AND HOW TO DEAL WITH THEM

Alarm code	Alarm symbol	Alarm description
e0 - e16; e21		Internal Error
e17 - e19		Short Circuit
e20		Voltage Error
e22 - e31		Internal Error
e32 - e35		Electronic system excess temperature
e37		Low voltage
e38		High voltage
e39 - e40		Pump blocked
e46		Pump Disconnected
e42		Dry operation
e56		Motor excess temperature (motor protector trips)
e57		Frequency of PWM external signal less than 100 Hz
e58		Frequency of PWM external signal greater than 5 kHz

CONDIZIONI DI ERRORE E DI RIPRISTINO

Condizione di errore			
Indicazione display		Descrizione	Ripristino
e0 - E16		Internal error	<ul style="list-style-type: none"> - Switch off system power. - Wait for the warning lights on the control panel to go off, then power the system again. - If the error persists, change the circulator.
e37		Low mains voltage (LP)	<ul style="list-style-type: none"> - Switch off system power. - Wait for the warning lights on the control panel to go off, then power the system again. - Check that the mains voltage is correct, if necessary reset it at the plate values.
e38		High mains voltage (HP)	<ul style="list-style-type: none"> - Switch off system power. - Wait for the warning lights on the control panel to go off, then power the system again. - Check that the mains voltage is correct, if necessary reset it at the plate values.
e32-e35		Critical overheating of electronic parts	<ul style="list-style-type: none"> - Switch off system power. - Wait for the warning lights on the control panel to go off. - Check that the system ventilation ducts are not blocked and that the environment temperature of the premises is correct.
e39-e40		Protection against overcurrent	<ul style="list-style-type: none"> - Check that the circulator turns freely - Check that any antifreeze added does not exceed the maximum percentage of 30%.
e21-e30		Voltage Error	<ul style="list-style-type: none"> - Switch off system power. - Wait for the warning lights on the control panel to go off, then power the system again. - Check that the mains voltage is correct, if necessary reset it at the plate values.
e31		Twin communication absent	<ul style="list-style-type: none"> - Check that the twin communication cable is intact. - Check that both circulators are powered.
e42		Dry operation	<ul style="list-style-type: none"> - Put the system under pressure.
e56		Motor excess temperature	<ul style="list-style-type: none"> - Switch off system power. - Wait for the motor to cool down - Power the system again
e57-e58		f < 100 Hz ; f > 5 kHz	<ul style="list-style-type: none"> - Check that the PWM external signal is operating and connected as specified

EVOPLUS SMALL / EVOPLUS SMALL SAN

WET ROTOR ELECTRONIC CIRCULATORS

INSTALLATION:

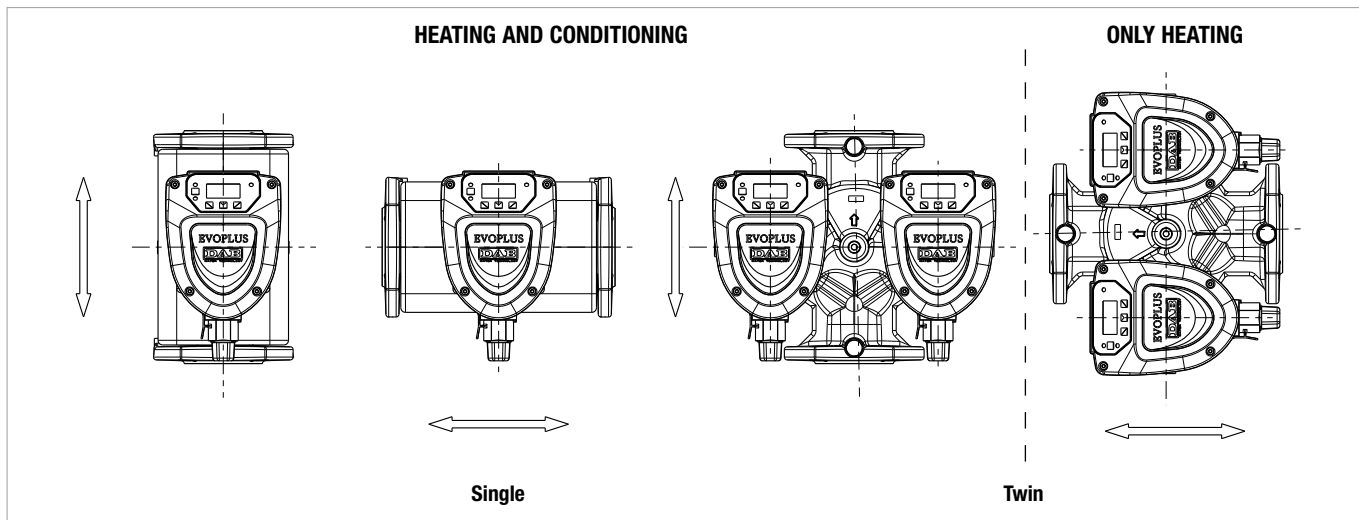

CONNECTION DIAGRAM

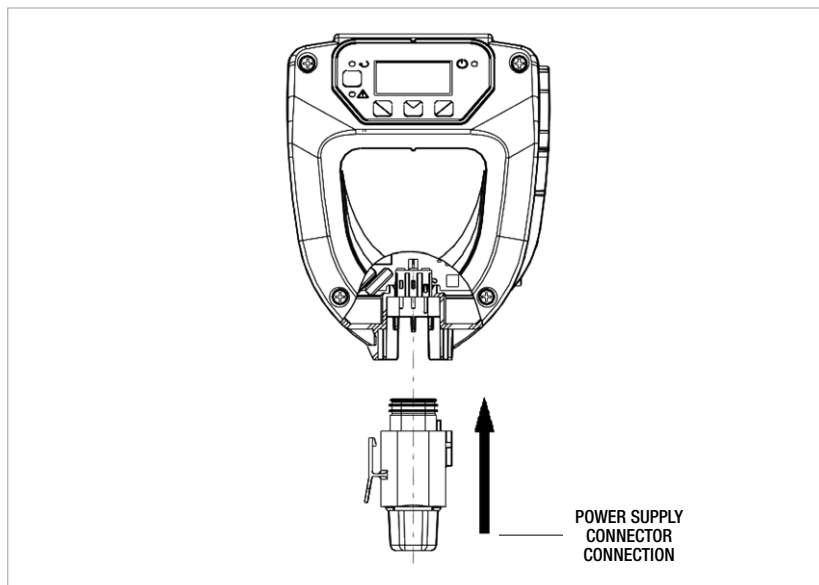
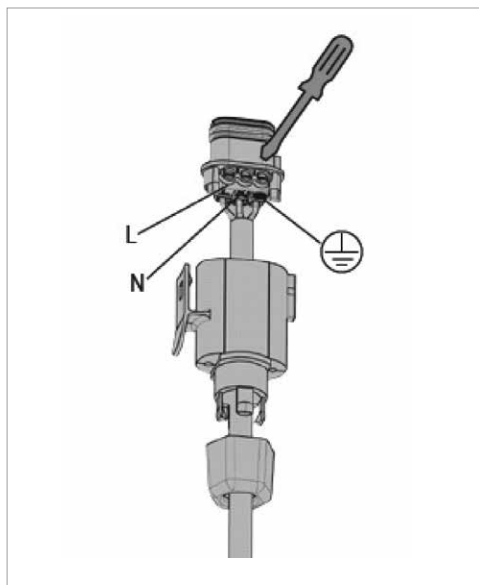

CONTROL PANEL DESCRIPTION

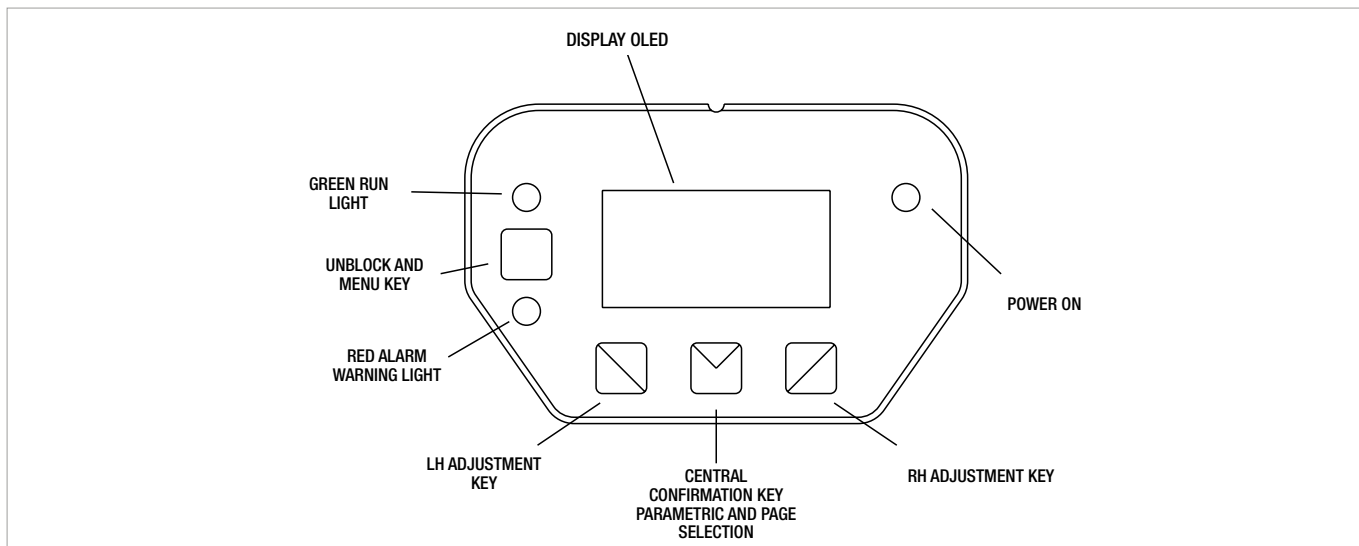

EVOPLUS SMALL / EVOPLUS SMALL SAN

WET ROTOR ELECTRONIC CIRCULATORS

BASIC MODULE

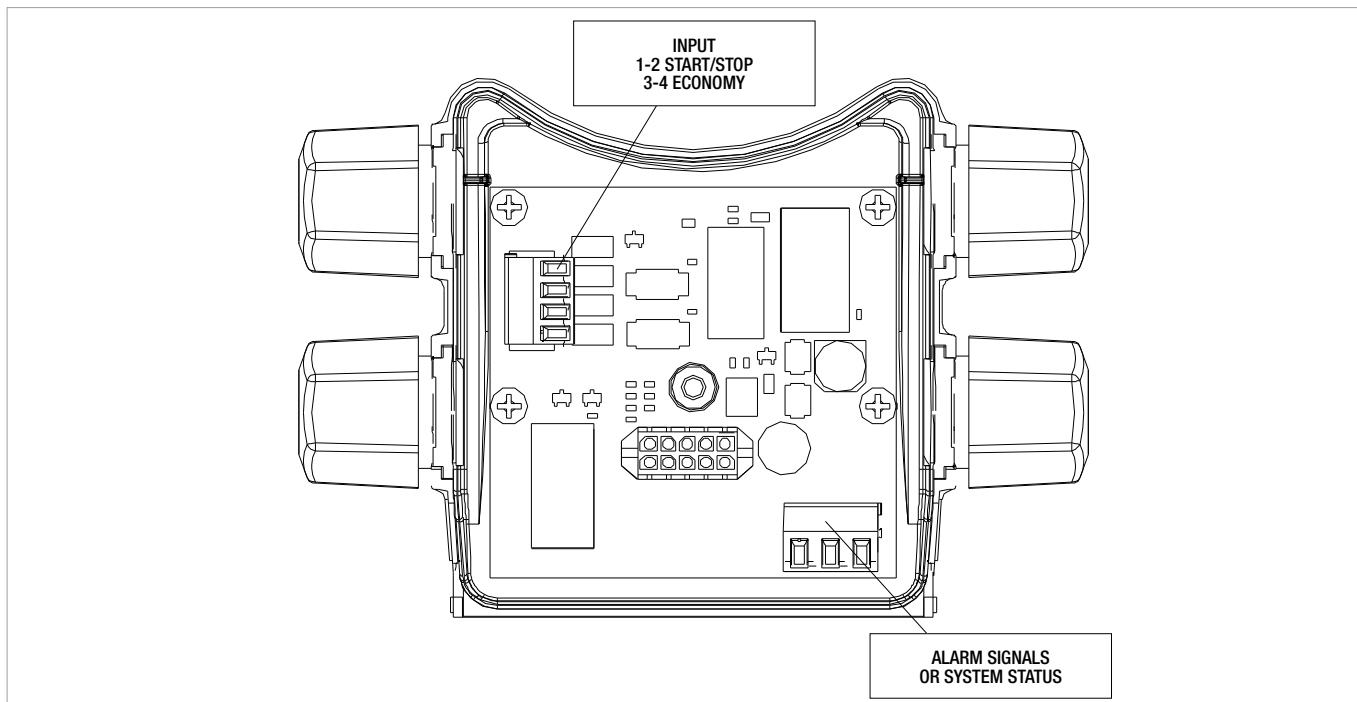

Digital inputs

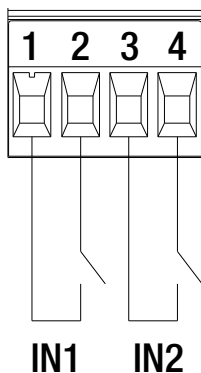

Input:
1-2 STAT/STOP
3-4 ECONOMY

Input	Terminal No.	Type of contact	Associated function
IN1	1	Clean contact	EXT: If it is activated from the control panel it will be possible to command the switching on and off of the pump in remote mode.
	2		
IN2	3	Clean contact	Economy: If it is activated from the control panel it will be possible to activate the set-point reduction function in remote mode.
	4		

If the **EXT** and **Economy** functions have been activated from the control panel, the system will behave as follows:

IN1	IN2	System Status
Aperto	Open	Pump stopped
Aperto	Closed	Pump stopped
Chiuso	Open	Pump running with set-point set by the user
Chiuso	Closed	Pump running with reduced set-point

Digital Outputs

Alarm signals or system status

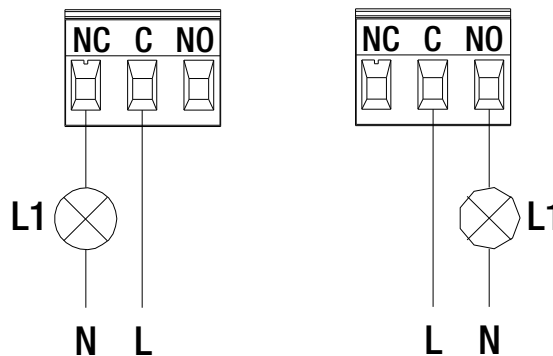

The function associated with the output OUT1 is "alarms present" and L1 lights up when there is an alarm in the system and switches off when no type of malfunction is found.

The function associated with the output OUT1 is "pump status" and L1 lights up when the pump is running and switches off when the pump is stopped.

Output	Terminal No.	Type of contact	Associated function
OUT1	NC	NC	<ul style="list-style-type: none"> • Presence/Absence of alarms in the system • Pump running/Pump stopped
	C	COM	
	NO	NO	

Output OUT1 is available on the pull-out 3-pole terminal board as specified in Table 3: Output OUT1 which also shows the type of contact (NC = Normally Closed, COM = Common, NO = Normally Open).

Characteristics of the output contacts	
Max. bearable voltage [V]	250
Max. bearable current [A]	5 - If resistive load 2,5 - If inductive load
Max. accepted cable section [mm ²]	1,5

EVOPLUS SMALL / EVOPLUS SMALL SAN

WET ROTOR ELECTRONIC CIRCULATORS

MULTI-FUNCTION MODULE

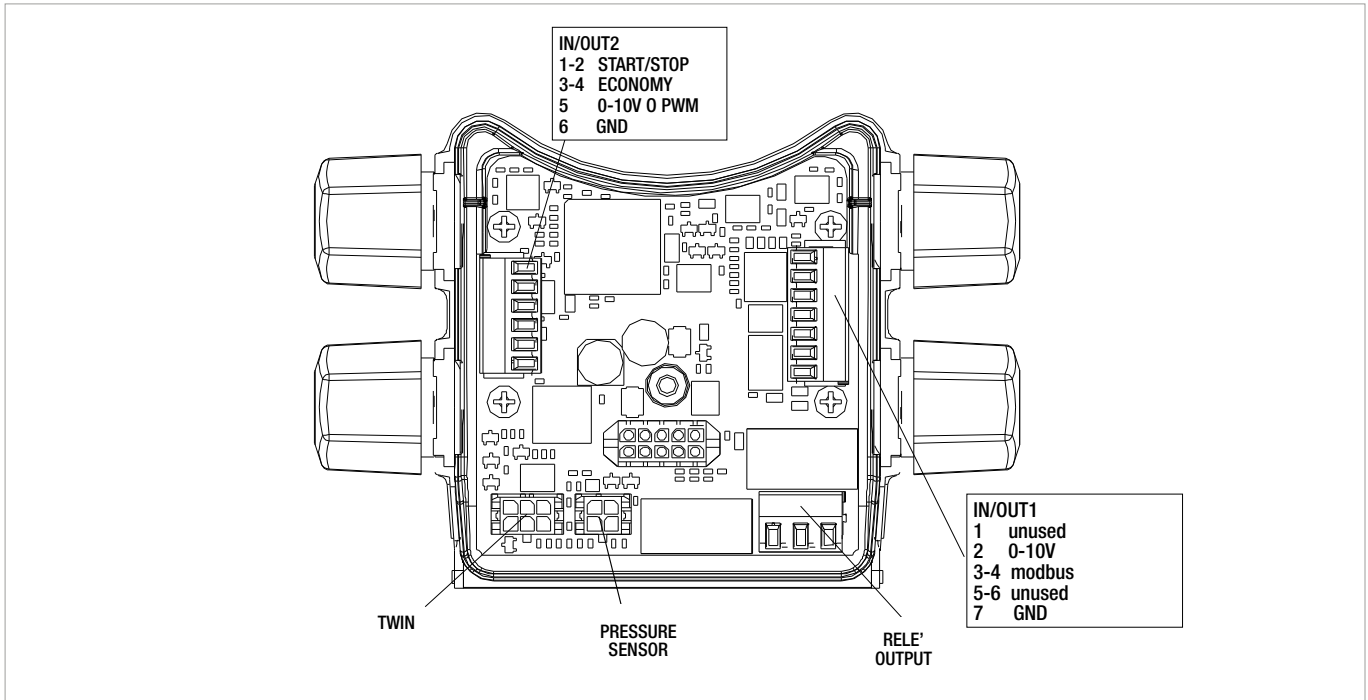

DIGITAL INPUTS

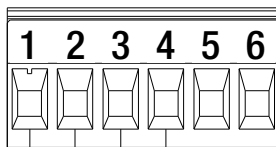

IN1 IN2

IN/OUT2
1-2 START/STOP
3-4 ECONOMY
5 0-10V, PWM and NTC
6 GND

Input	Terminal No.	Type of contact	Associated function
IN1	1	Clean contact	EXT: If it is activated from the control panel it will be possible to command the switching on and off of the pump in remote mode.
	2		
IN2	3	Clean contact	Economy: If it is activated from the control panel it will be possible to activate the set-point reduction function in remote mode.
	4		

If the **EXT** and **Economy** functions have been activated from the control panel, the system will behave as follows:

IN1	IN2	System status
Open	Open	Pump stopped
Open	Closed	Pump stopped
Closed	Open	Pump running with set-point set by the user
Closed	Closed	Pump running with reduced set-point

MODBUS

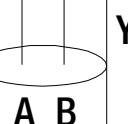
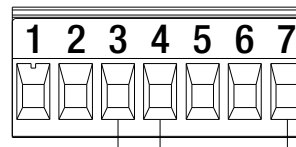

IN/OUT1
1 unused
2 0-10V
3-4 modbus
5-6 unused
7 GND

The multifunction expansion module provides serial communication through an input RS-485. The communication is achieved according to MODBUS specifications.

With MODBUS it is possible to set the circulator operating parameters in remote mode such as, for example, the desired differential pressure, the regulating mode, etc. At the same time the circulator can provide important information on the system status.

Modbus Terminals	Terminal No.	Description
A	3	Terminal not inverted (+)
B	4	Terminal inverted (-)
Y	7	GND

LONBUS

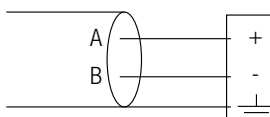

Gateway/ Evoplus connection

With some modules on the market it is possible to make the circulator available also to a LonWorks network, and therefore its status and the possibility of varying the circulator parameters, reading or modifying the registers as described in the Manual "Instructions for use of the Modbus Protocol" available at the address „<http://www.dabpumps.it/evoplus>“.

EVOPLUS SMALL / EVOPLUS SMALL SAN

WET ROTOR ELECTRONIC CIRCULATORS

ANALOGUE INPUT PWM AND NTC

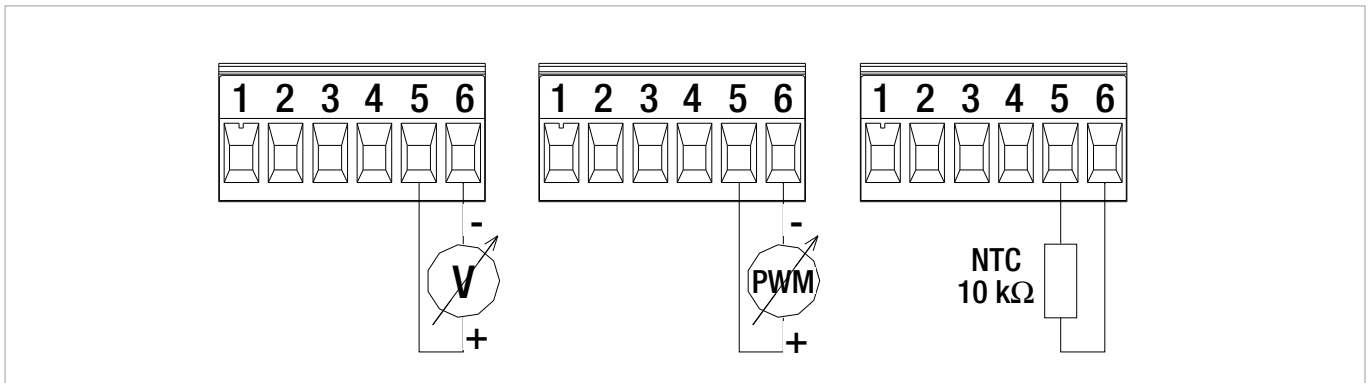

DIGITAL OUTPUTS

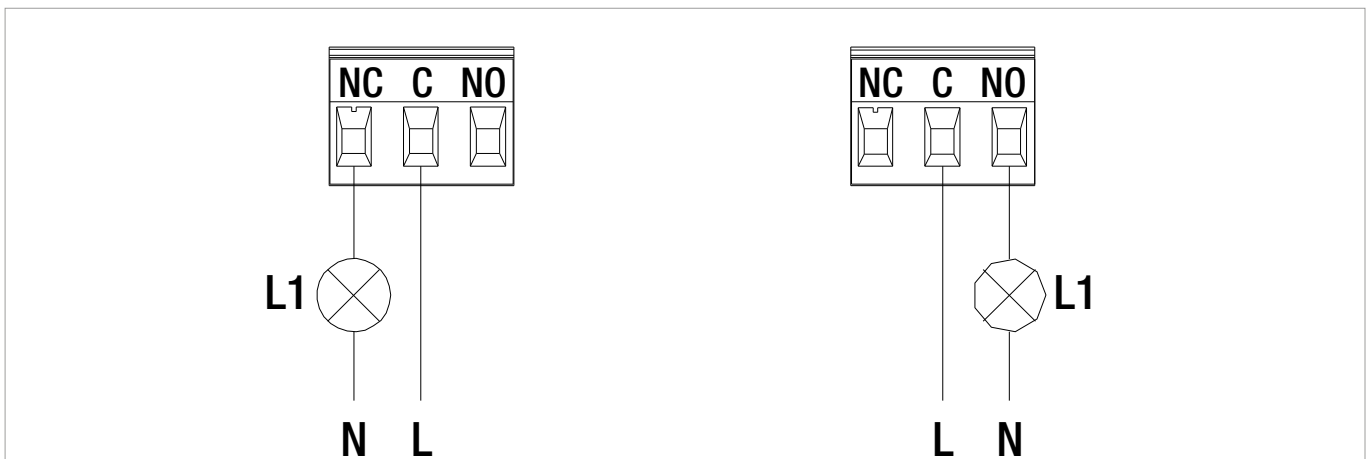

The function associated with the output OUT1 is "pump status" and L1 lights up when the pump is running and switches off when the pump is stopped.

The function associated with the output OUT2 is "alarms present" and L1 lights up when there is an alarm in the system and switches off when no type of malfunction is found.

Output	Terminal No.	Type of contact	Associated function
OUT1	NC	NC	<ul style="list-style-type: none"> • Presence/Absence of alarms in the system • Pump running/Pump stopped
	C	COM	
	NO	NO	

Output OUT1 is available on the pull-out 3-pole terminal board which also shows the type of contact (NC=Normally Closed, COM=Common, NO=Normally Open)

Characteristics of the output contacts	
Max. bearable voltage [V]	250
Max. bearable current [A]	5 - If resistive load 2,5 - If inductive load
Max. accepted cable section [mm ²]	1,5

EVOPLUS SMALL - ELECTRONIC CIRCULATORS FOR HEATING AND AIR-CONDITIONING SYSTEMS

MODEL	CENTRE DISTANCE mm	UNIONS ON REQUEST		VOLTAGE 50/60 Hz	P1 MAX W	In A	EEI	MINIMUM HEAD PRESSURE			WEIGHT Kg
		STANDARD	SPECIAL					t°	90°	100°	
EVOPLUS 40/180 M	180	1" F	¾" F - 1¼" M	220/240 V	70	0,52	EEI ≤ 0,23	m.c.a.	20	25	4,5
EVOPLUS 60/180 M	180	1" F	¾" F - 1¼" M	220/240 V	100	0,72	EEI ≤ 0,22	m.c.a.	20	25	4,5

Liquid temperature range: da -10°C a +110°C - Maximum operating pressure: 16 bar (1600 kPa)

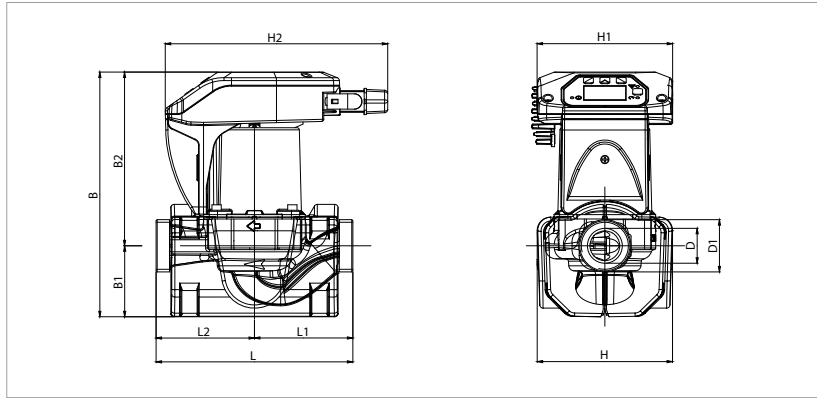

L	L1	L2	B	B1	B2
180	90	90	224	65	159

D	D1	H	H1	H2
32	1½	124	124	204

The performance curves are based on kinematic viscosity values = 1 mm²/s and density equivalent to 1000 kg/m³. Tolerance of curves to ISO 9906. Constant curve available on DNA.

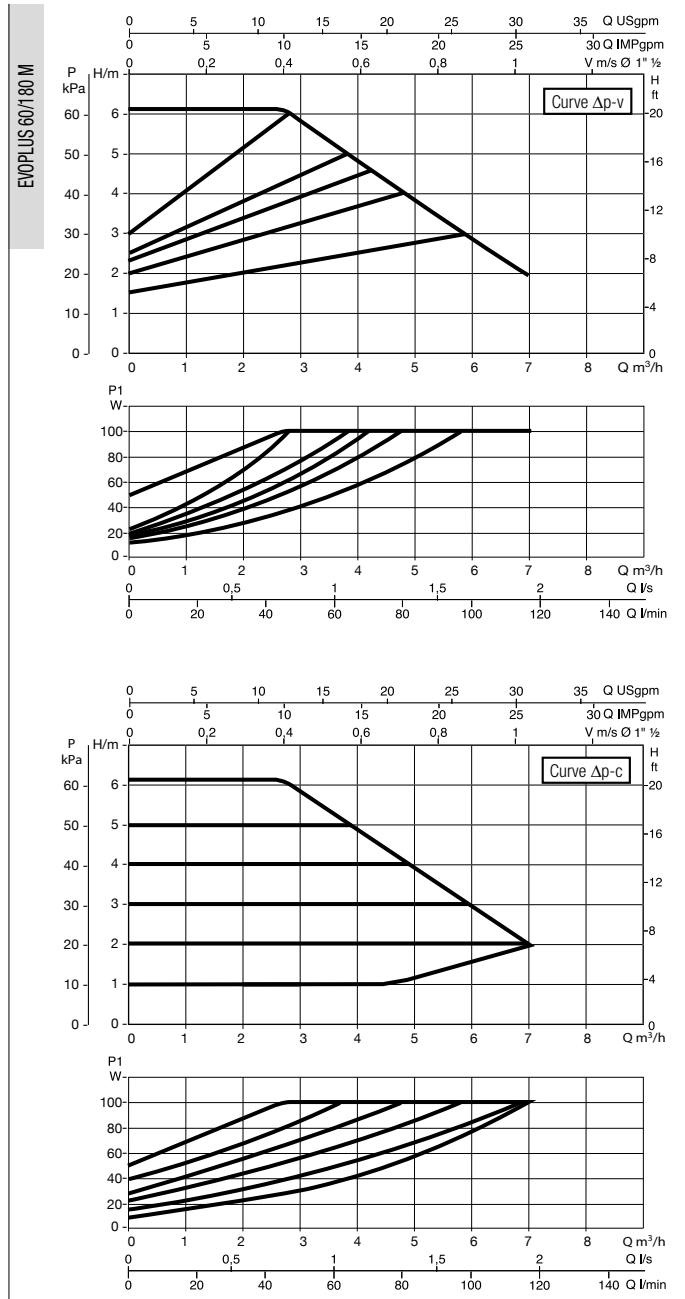
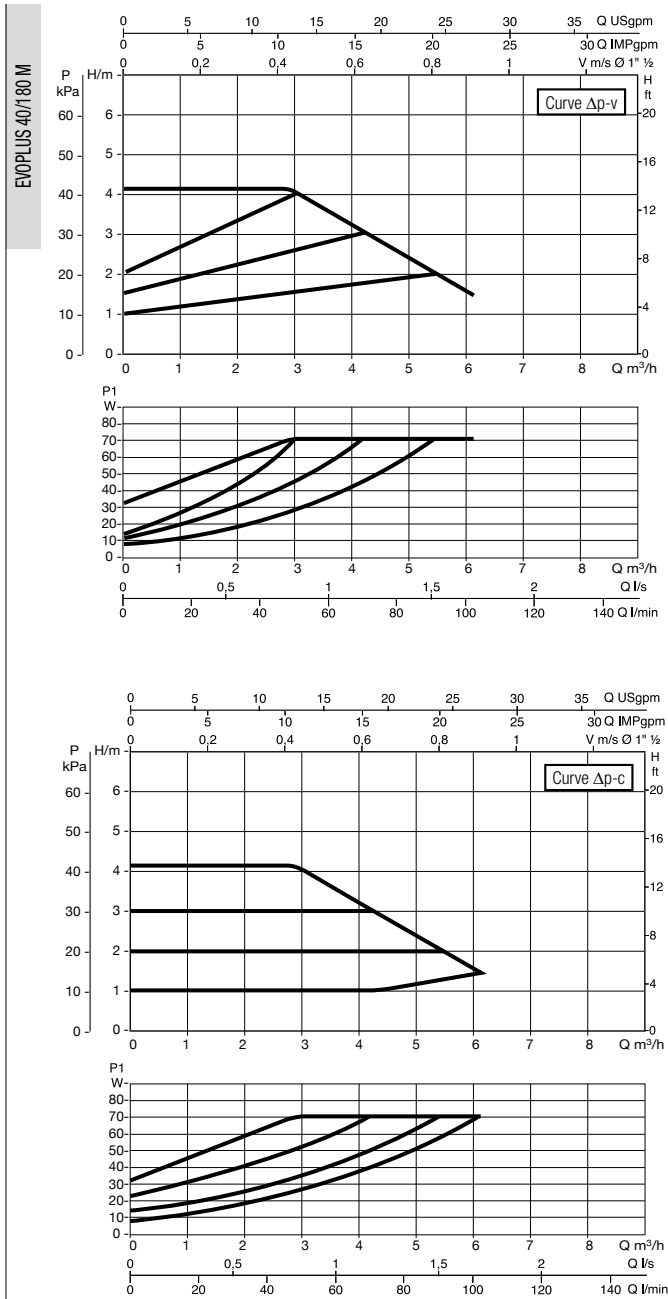

EVOPLUS SMALL - ELECTRONIC CIRCULATORS FOR HEATING AND AIR-CONDITIONING SYSTEMS

MODEL	CENTRE DISTANCE mm	UNIONS ON REQUEST		VOLTAGE 50/60 Hz	P1 MAX W	In A	EEI	MINIMUM HEAD PRESSURE			WEIGHT Kg
		STANDARD	SPECIAL					t°	90°	100°	
EVOPLUS 80/180 M	180	1" F	¾" F - 1¼" M	220/240 V	135	0,95	EEI ≤ 0,22	m.c.a.	20	25	4,5
EVOPLUS 110/180 M	180	1" F	¾" F - 1¼" M	220/240 V	170	1,18	EEI ≤ 0,22	m.c.a.	20	25	4,5

Liquid temperature range: da -10°C a +110°C - Maximum operating pressure: 16 bar (1600 kPa)

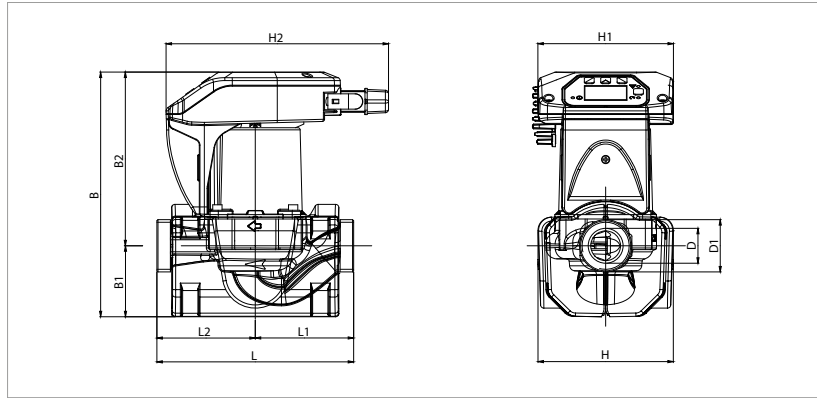

L	L1	L2	B	B1	B2
180	90	90	224	65	159

D	D1	H	H1	H2
32	1½	124	124	204

The performance curves are based on kinematic viscosity values = 1 mm²/s and density equivalent to 1000 kg/m³. Tolerance of curves to ISO 9906. Constant curve available on DNA.

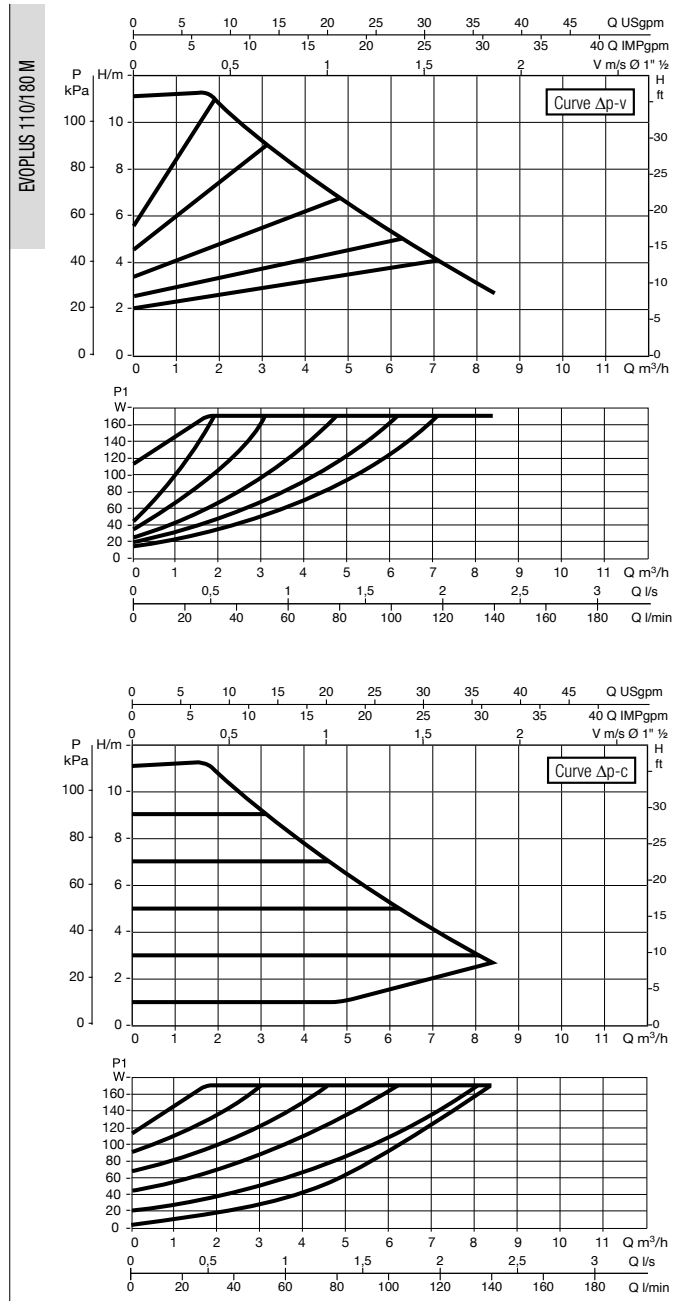
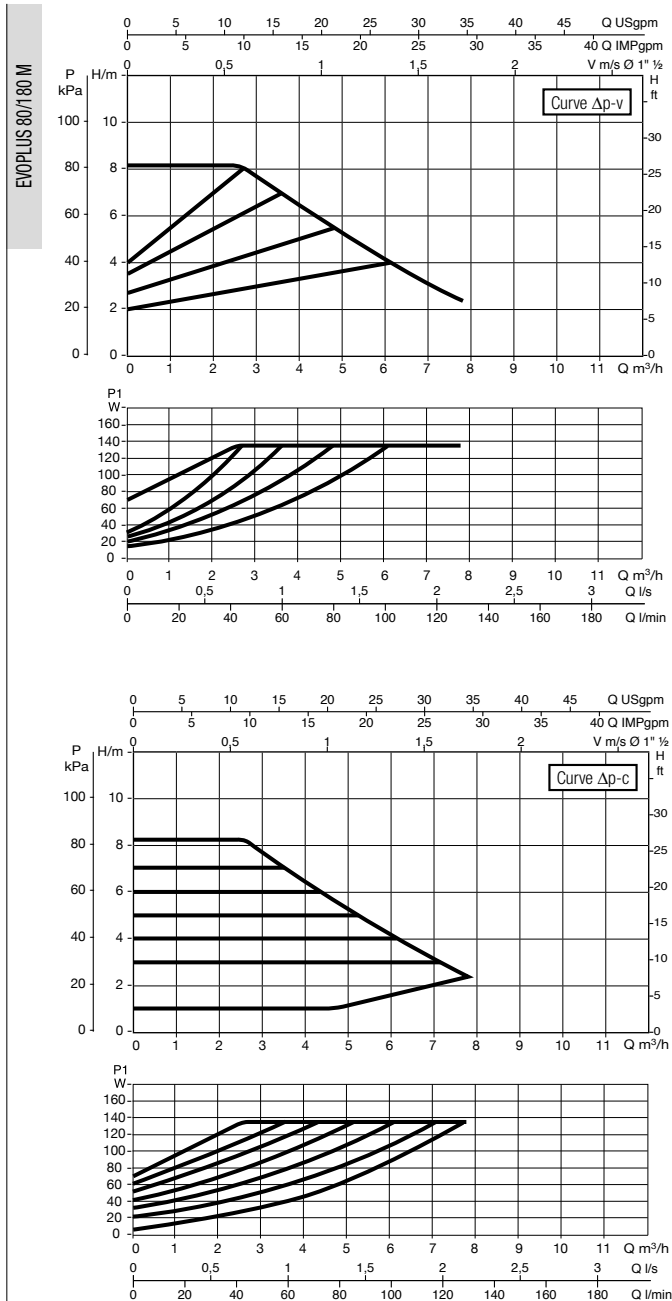

EVOPLUS SMALL - ELECTRONIC CIRCULATORS FOR HEATING AND AIR-CONDITIONING SYSTEMS

MODEL	CENTRE DISTANCE mm	UNIONS ON REQUEST		VOLTAGE 50/60 Hz	P1 MAX W	In A	EEI	MINIMUM HEAD PRESSURE			WEIGHT Kg
		STANDARD	SPECIAL					t°	90°	100°	
EVOPLUS 40/180 XM	180	2" G	1 1/4" F	220/240 V	70	0,51	EEI ≤ 0,21	m.c.a.	20	25	4,7
EVOPLUS 60/180 XM	180	2" G	1 1/4" F	220/240 V	100	0,71	EEI ≤ 0,21	m.c.a.	20	25	4,7

Liquid temperature range: da -10°C a +110°C - Maximum operating pressure: 16 bar (1600 kPa)

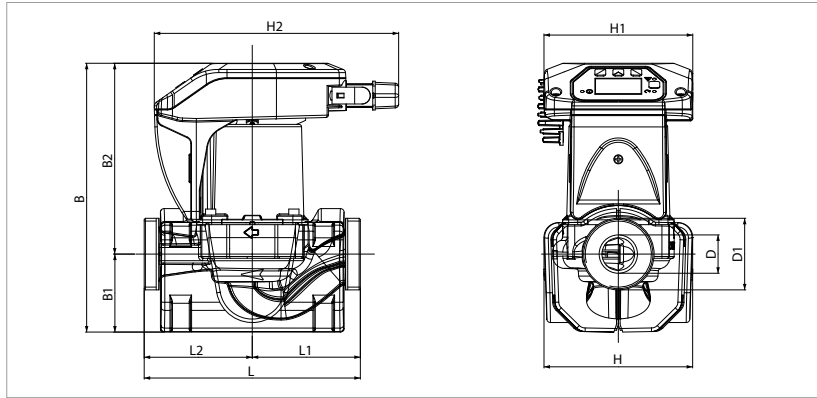

L	L1	L2	B	B1	B2
180	90	90	224	65	159

D	D1	H	H1	H2
32	2"	124	124	204

The performance curves are based on kinematic viscosity values = 1 mm²/s and density equivalent to 1000 kg/m³. Tolerance of curves to ISO 9906. Constant curve available on DNA.

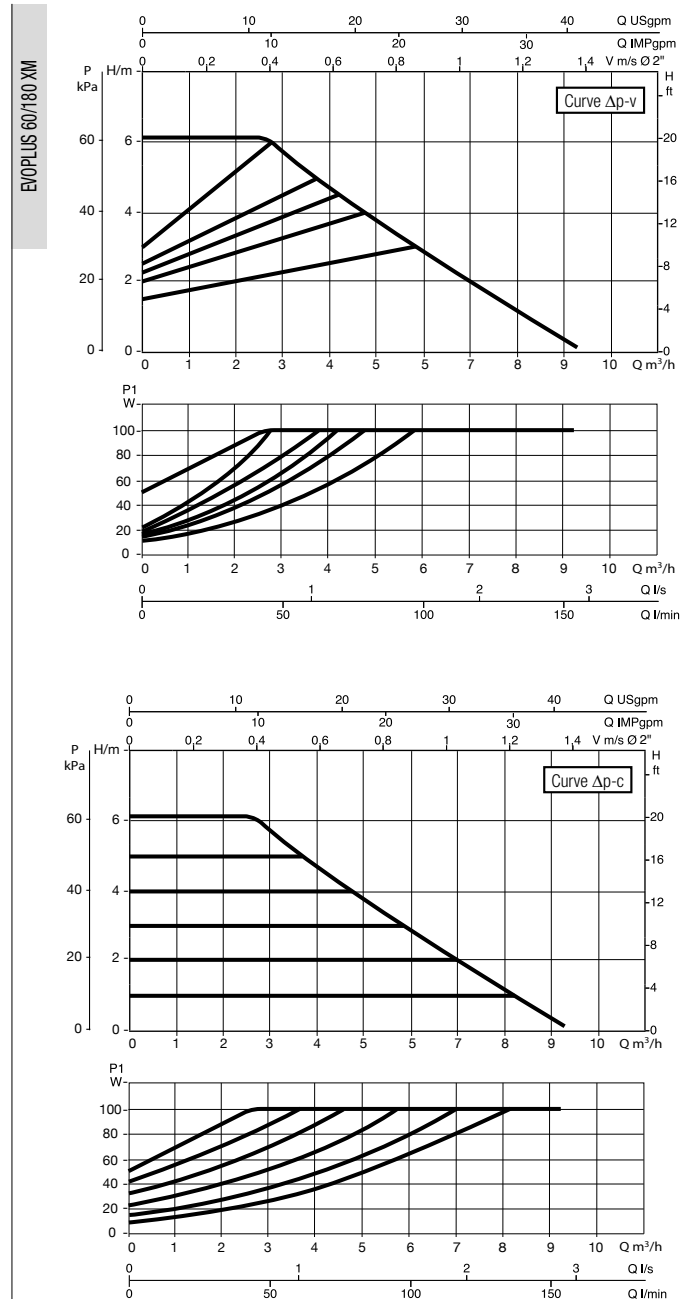
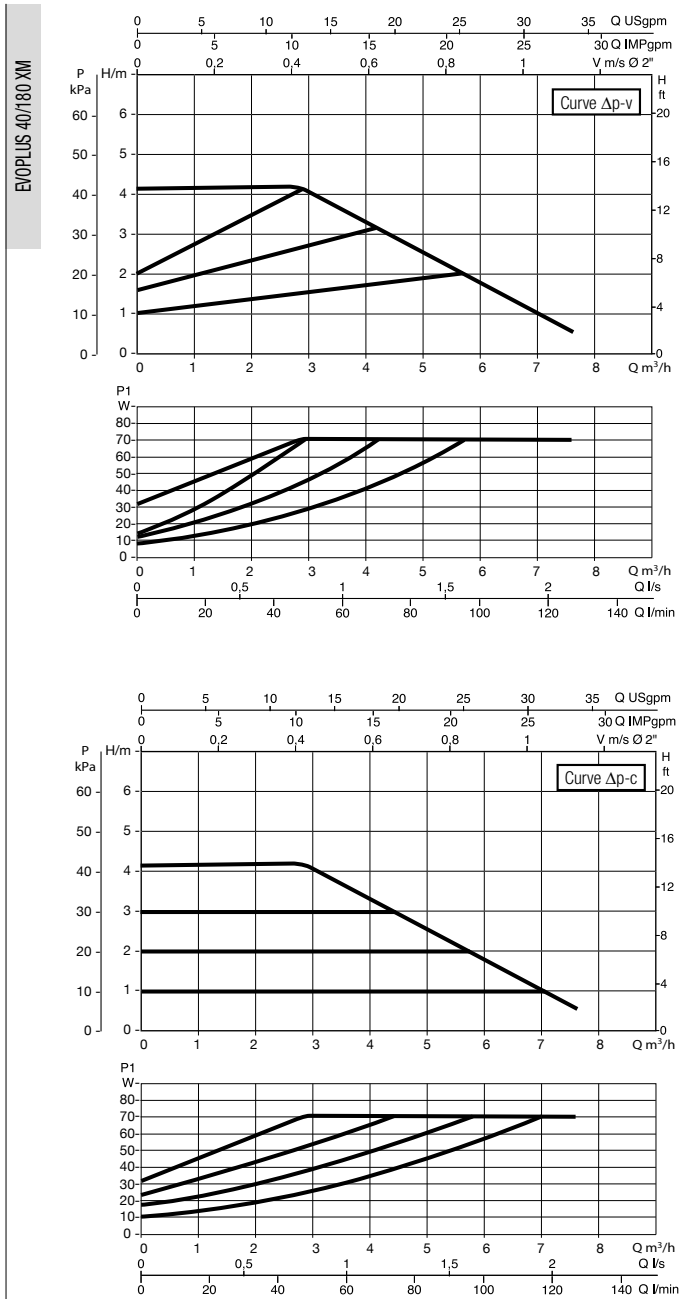

EVOPLUS SMALL - ELECTRONIC CIRCULATORS FOR HEATING AND AIR-CONDITIONING SYSTEMS

MODEL	CENTRE DISTANCE mm	UNIONS ON REQUEST		VOLTAGE 50/60 Hz	P1 MAX W	In A	EEI	MINIMUM HEAD PRESSURE			WEIGHT Kg
		STANDARD	SPECIAL					t°	90°	100°	
EVOPLUS 80/180 XM	180	2" G	1 1/4" F	220/240 V	135	0,93	EEI ≤ 0,21	m.c.a.	20	25	4,7
EVOPLUS 110/180 XM	180	2" G	1 1/4" F	220/240 V	170	1,18	EEI ≤ 0,21	m.c.a.	20	25	4,7

Liquid temperature range: da -10°C a +110°C - Maximum operating pressure: 16 bar (1600 kPa)

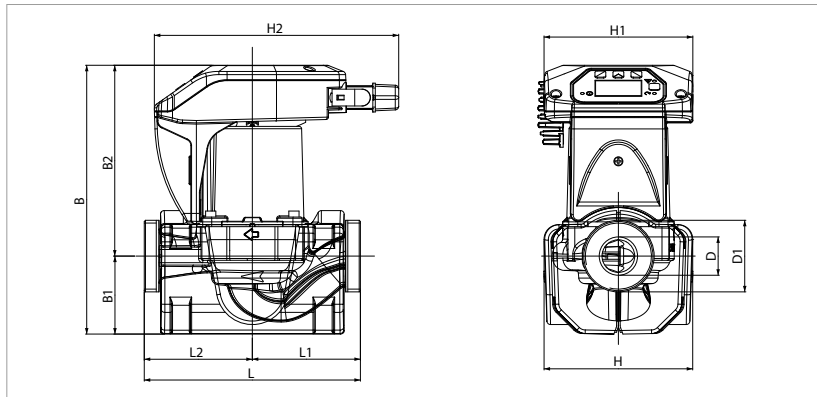

L	L1	L2	B	B1	B2
180	90	90	224	65	159

D	D1	H	H1	H2
32	2"	124	124	204

The performance curves are based on kinematic viscosity values = 1 mm²/s and density equivalent to 1000 kg/m³. Tolerance of curves to ISO 9906. Constant curve available on DNA.

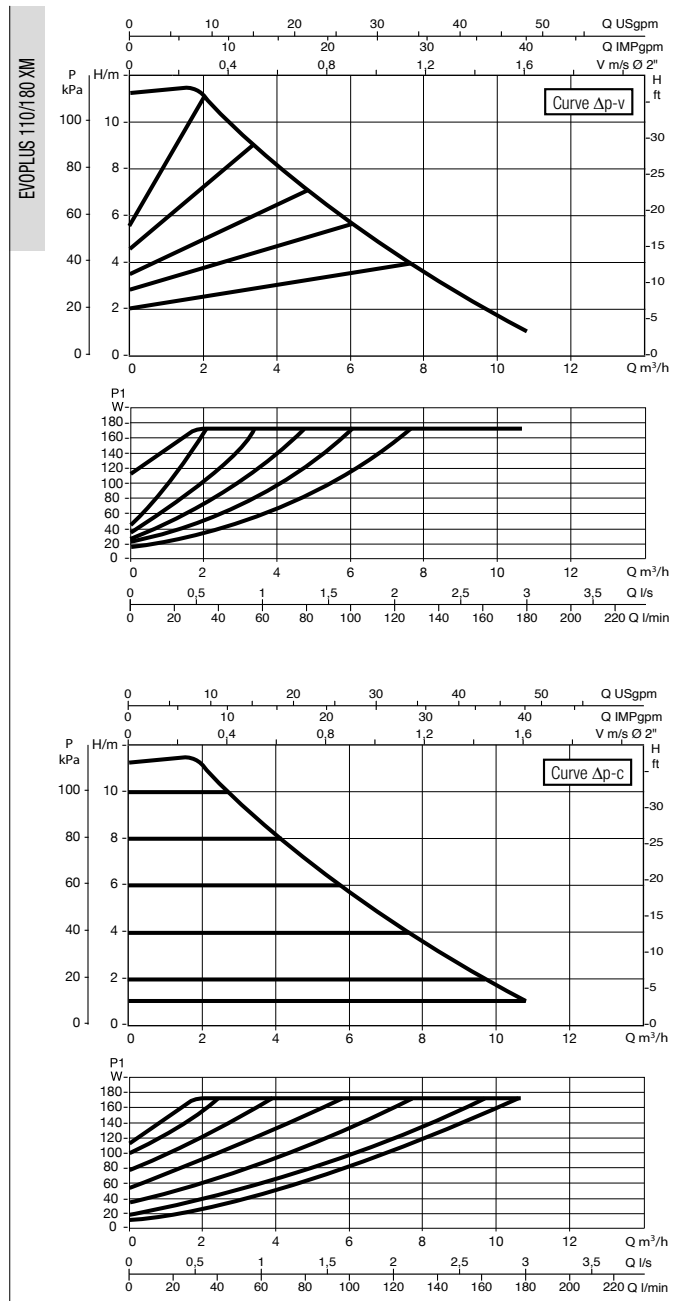
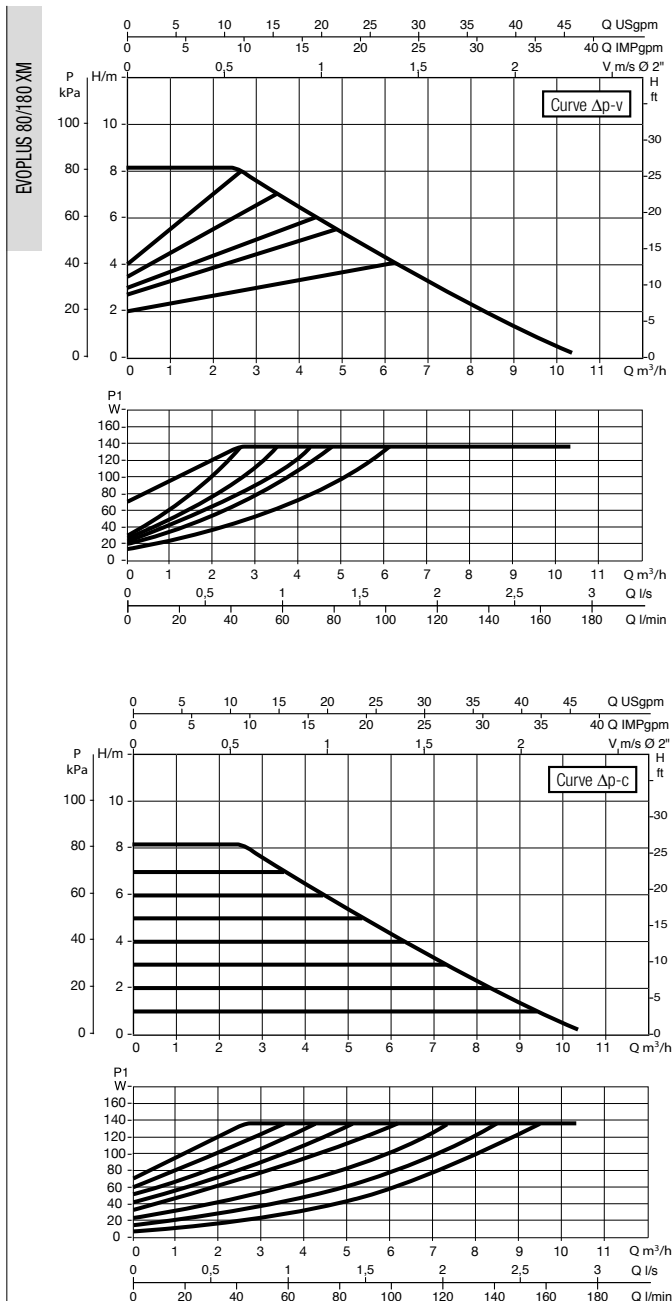

EVOPLUS SMALL - ELECTRONIC CIRCULATORS FOR HEATING AND AIR-CONDITIONING SYSTEMS

MODEL	CENTRE DISTANCE mm	COUNTERFLANGES ON REQUEST	VOLTAGE 50/60 Hz	P1 MAX W	In A	EEI	MINIMUM HEAD PRESSURE			WEIGHT Kg
							t°	90°	100°	
EVOPLUS B 40/220.32 M	220	DN 32 PN 6	220/240 V	85	0,55	EEI ≤ 0,22	m.c.a.	20	25	7,5
EVOPLUS B 60/220.32 M	220	DN 32 PN 6	220/240 V	110	0,75	EEI ≤ 0,22	m.c.a.	20	25	7,5

Liquid temperature range: da -10°C a +110°C - Maximum operating pressure: 16 bar (1600 kPa)

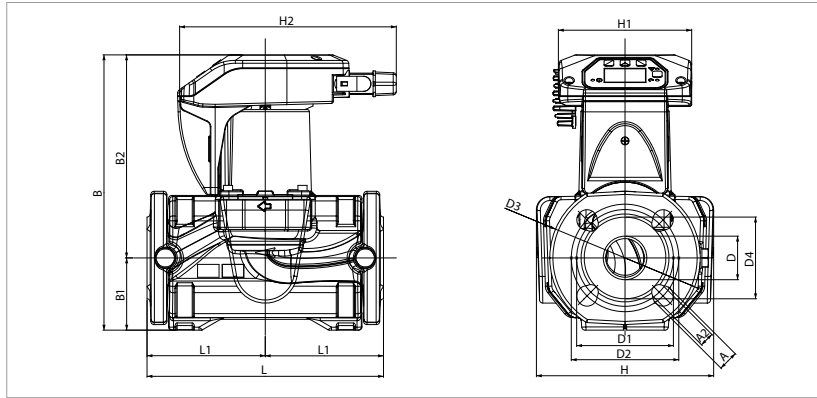

L	L1	L2	A	A2	B	B1	B2
220	110	110	19	14	256	67	189

D	D1	D2	D3	D4	H	H1	H2
40	90	100	140	76	165	124	204

The performance curves are based on kinematic viscosity values = 1 mm²/s and density equivalent to 1000 kg/m³. Tolerance of curves to ISO 9906. Constant curve available on DNA.

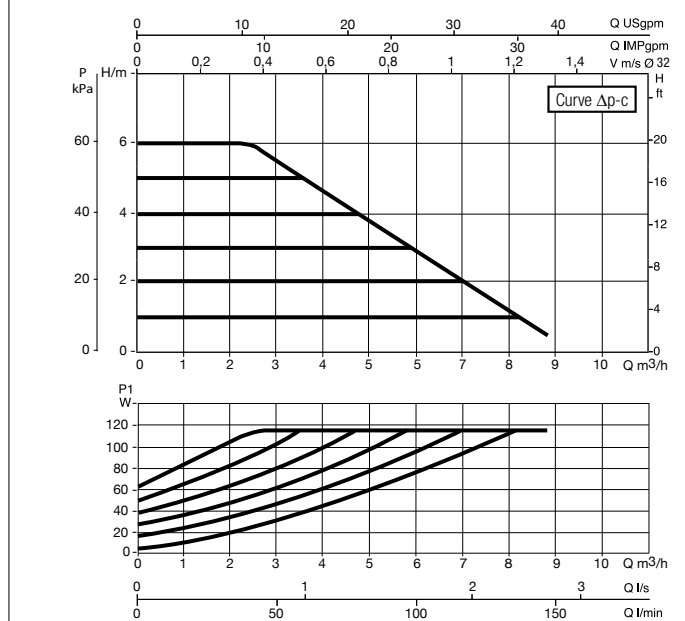
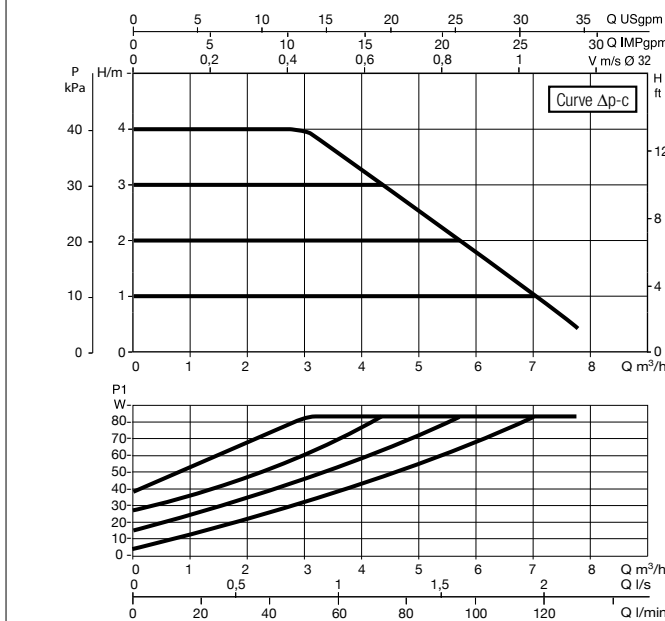
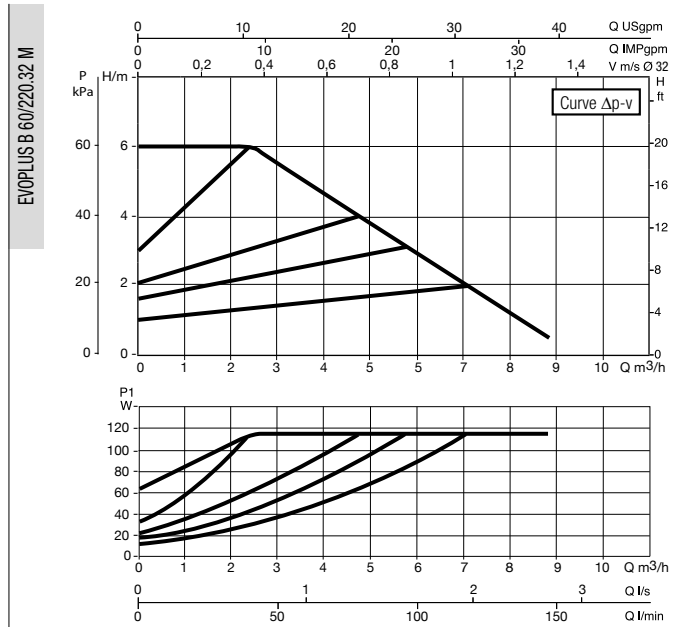
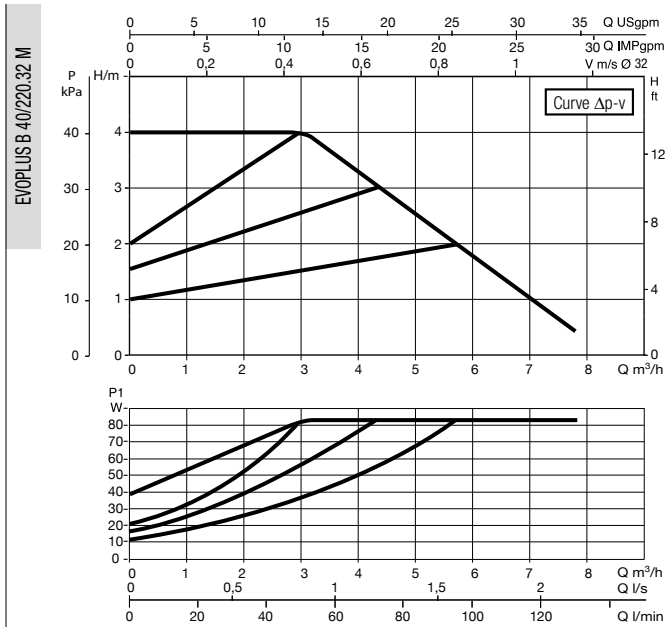

EVOPLUS SMALL - ELECTRONIC CIRCULATORS FOR HEATING AND AIR-CONDITIONING SYSTEMS

MODEL	CENTRE DISTANCE mm	COUNTERFLANGES ON REQUEST	VOLTAGE 50/60 Hz	P1 MAX W	In A	EEI	MINIMUM HEAD PRESSURE			WEIGHT Kg
							t°	90°	100°	
EVOPLUS B 80/220.32 M	220	DN 32 PN 6	220/240 V	150	0,97	EEI ≤ 0,22	m.c.a.	20	25	7,5
EVOPLUS B 110/220.32 M	220	DN 32 PN 6	220/240 V	200	1,3	EEI ≤ 0,22	m.c.a.	20	25	7,5

Liquid temperature range: da -10°C a +110°C - Maximum operating pressure: 16 bar (1600 kPa)

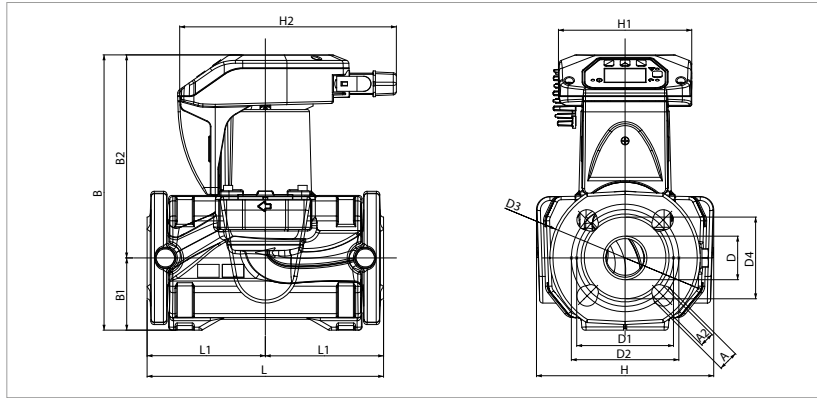

L	L1	L2	A	A2	B	B1	B2
220	110	110	19	14	256	67	189

D	D1	D2	D3	D4	H	H1	H2
40	90	100	140	76	165	124	204

The performance curves are based on kinematic viscosity values = 1 mm²/s and density equivalent to 1000 kg/m³. Tolerance of curves to ISO 9906. Constant curve available on DNA.

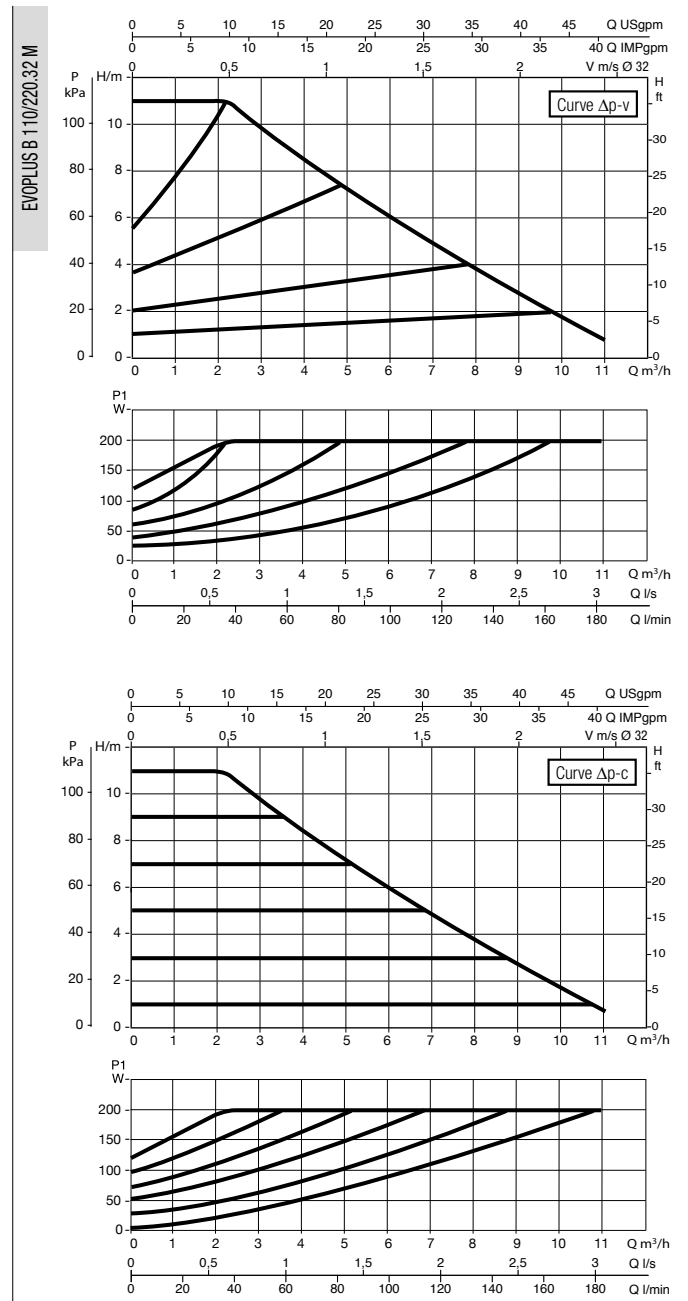
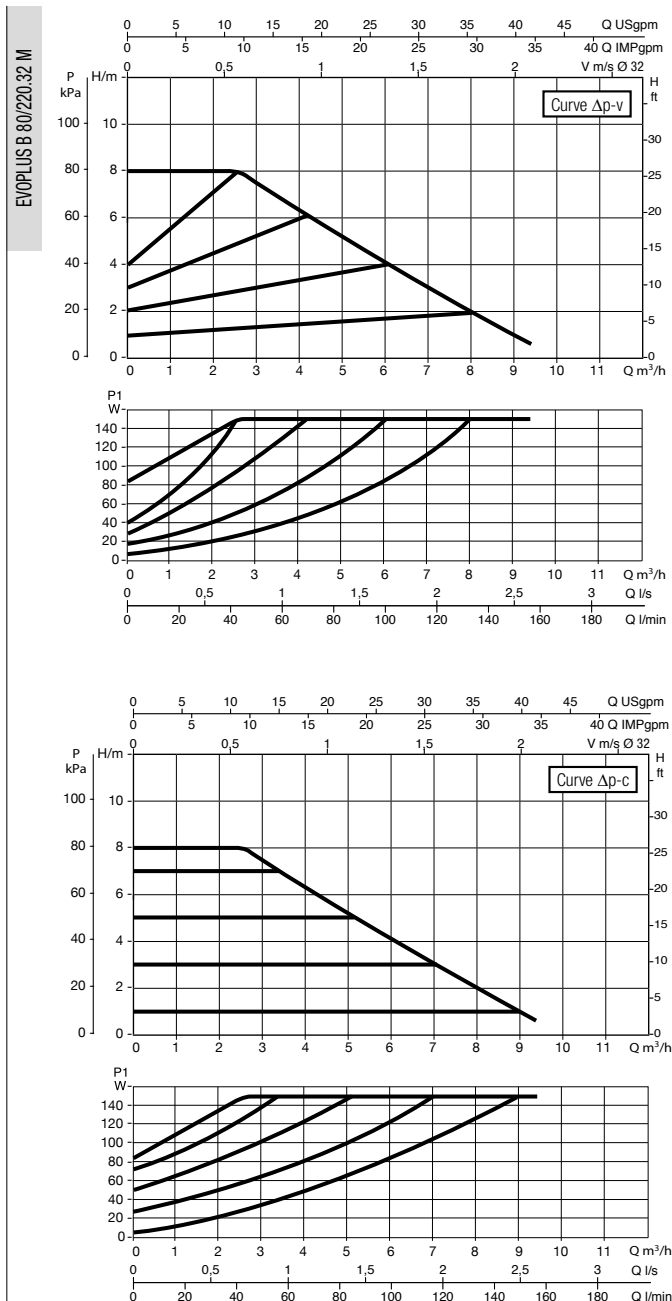

EVOPLUS SMALL - ELECTRONIC CIRCULATORS FOR HEATING AND AIR-CONDITIONING SYSTEMS

MODEL	CENTRE DISTANCE mm	COUNTERFLANGES ON REQUEST	VOLTAGE 50/60 Hz	P1 MAX W	In A	EEI	MINIMUM HEAD PRESSURE			WEIGHT Kg
							t°	90°	100°	
EVOPLUS B 40/250.40 M	250	DN 40 PN 10	220/240 V	75	0,55	EEI ≤ 0,21	m.c.a.	20	25	7,5
EVOPLUS B 60/250.40 M	250	DN 40 PN 10	220/240 V	105	0,75	EEI ≤ 0,21	m.c.a.	20	25	7,5

Liquid temperature range: da -10°C a +110°C - Maximum operating pressure: 16 bar (1600 kPa)

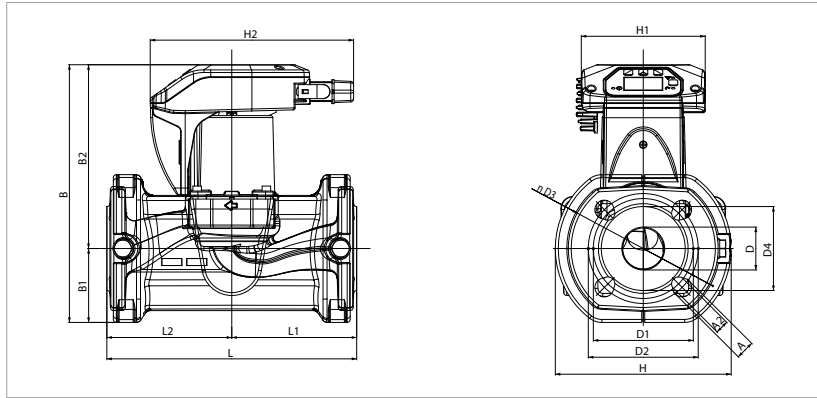

L	L1	L2	A	A2	B	B1	B2
250	125	125	19	14	258	74	184

D	D1	D2	D3	D4	H	H1	H2
43	100	110	150	84	176	124	204

The performance curves are based on kinematic viscosity values = 1 mm²/s and density equivalent to 1000 kg/m³. Tolerance of curves to ISO 9906. Constant curve available on DNA.

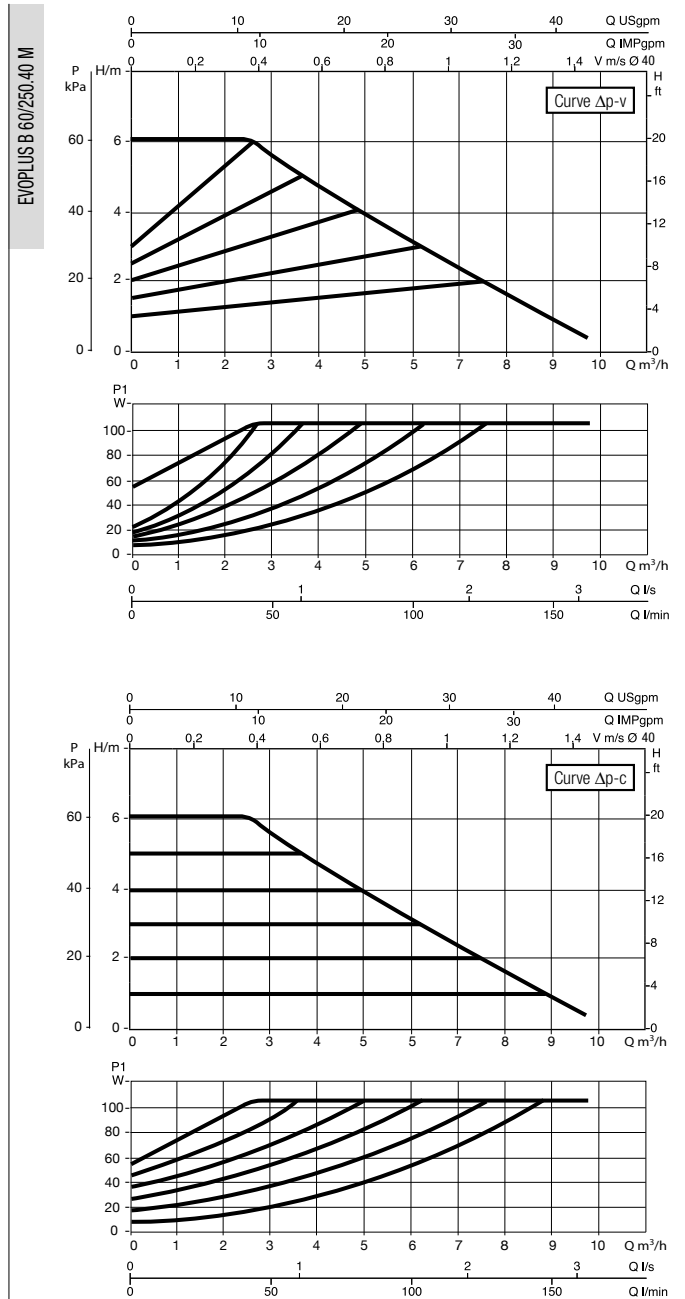
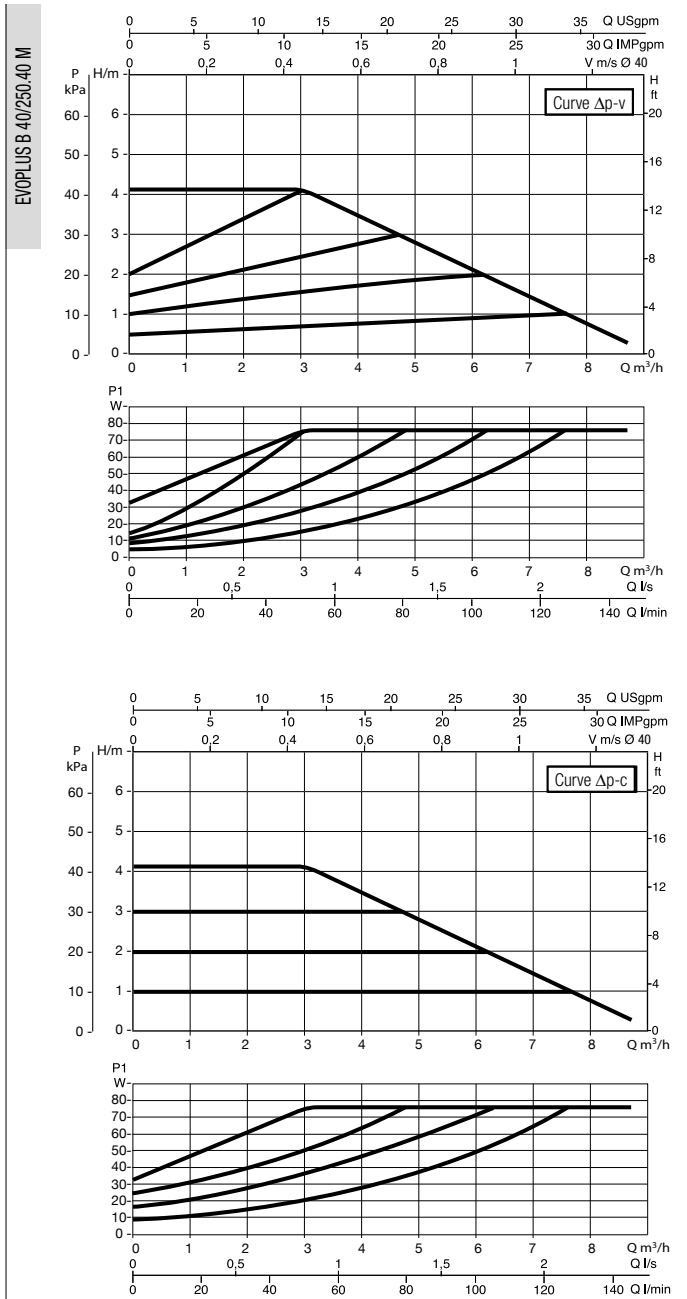

EVOPLUS SMALL - ELECTRONIC CIRCULATORS FOR HEATING AND AIR-CONDITIONING SYSTEMS

MODEL	CENTRE DISTANCE mm	COUNTERFLANGES ON REQUEST	VOLTAGE 50/60 Hz	P1 MAX W	In A	EEI	MINIMUM HEAD PRESSURE			WEIGHT Kg
							t°	90°	100°	
EVOPLUS B 80/250.40 M	250	DN 40 PN 10	220/240 V	140	0,97	EEI ≤ 0,21	m.c.a.	20	25	7,5
EVOPLUS B 110/250.40 M	250	DN 40 PN 10	220/240 V	190	1,3	EEI ≤ 0,21	m.c.a.	20	25	7,5

Liquid temperature range: da -10°C a +110°C - Maximum operating pressure: 16 bar (1600 kPa)

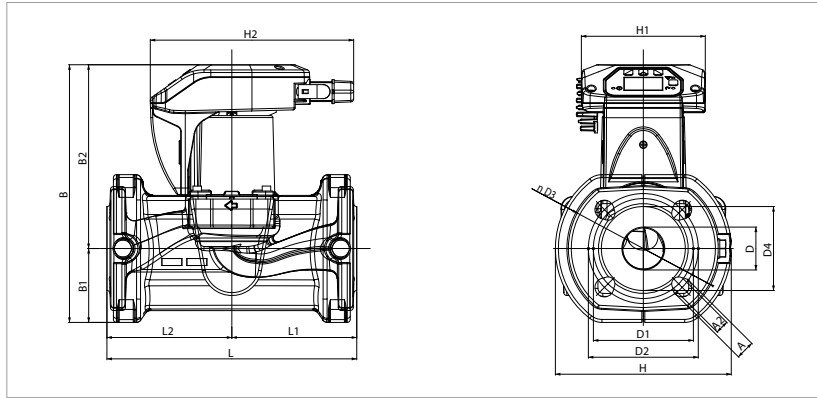

L	L1	L2	A	A2	B	B1	B2
250	125	125	19	14	258	74	184

D	D1	D2	D3	D4	H	H1	H2
43	100	110	150	84	176	124	204

The performance curves are based on kinematic viscosity values = 1 mm²/s and density equivalent to 1000 kg/m³. Tolerance of curves to ISO 9906. Constant curve available on DNA.

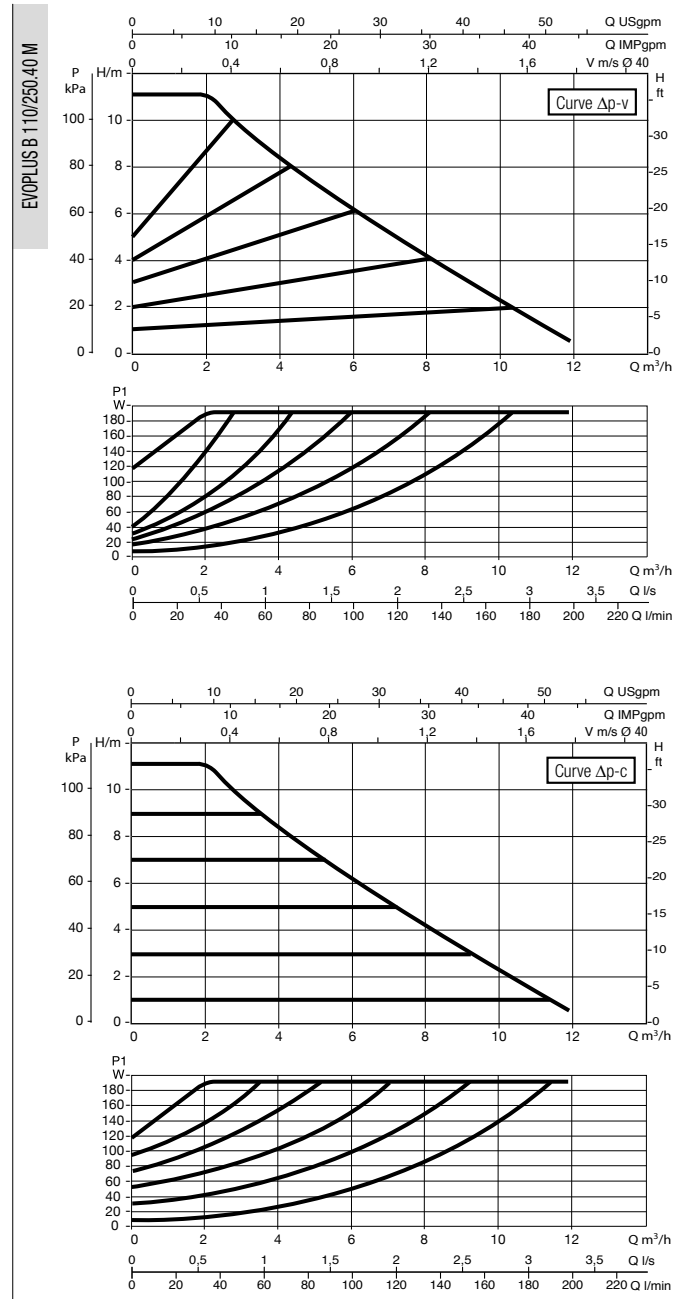
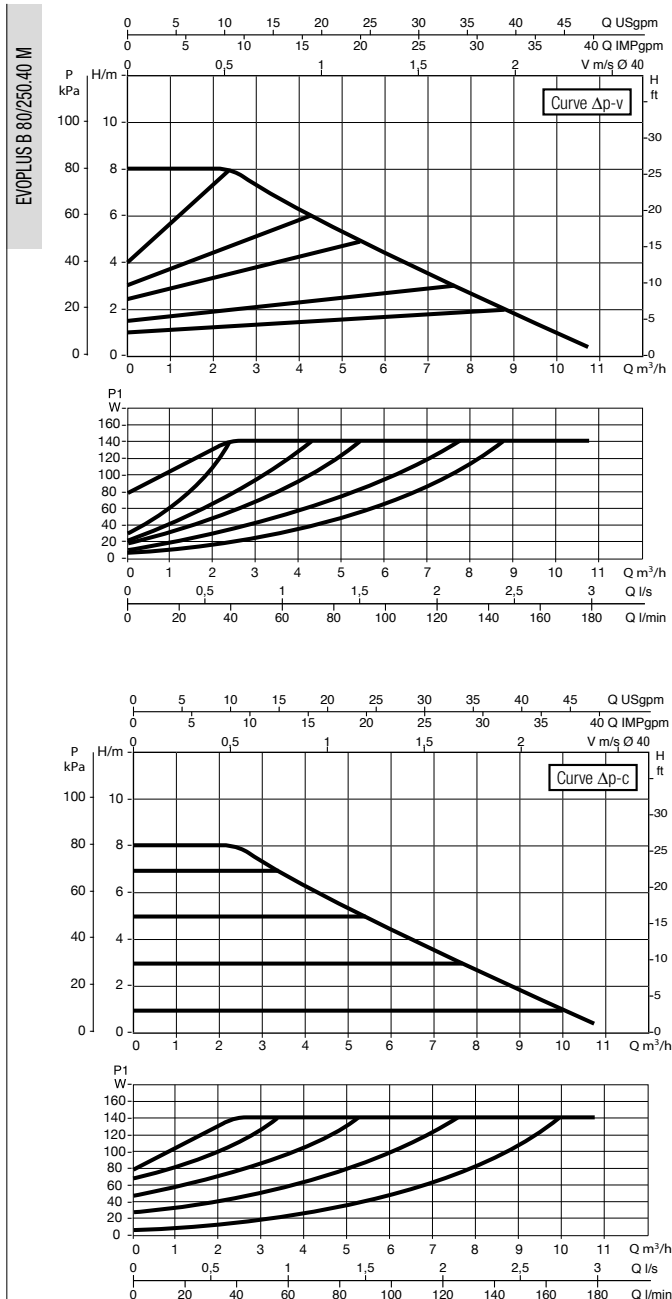

EVOPLUS SMALL - ELECTRONIC CIRCULATORS FOR HEATING AND AIR-CONDITIONING SYSTEMS

MODEL	CENTRE DISTANCE mm	COUNTERFLANGES ON REQUEST	VOLTAGE 50/60 Hz	P1 MAX W	In A	EEI	MINIMUM HEAD PRESSURE			WEIGHT Kg
							t°	90°	100°	
EVOPLUS D 40/220.32 M	220	DN 32 PN 6	220/240 V	85	0,55	EEI ≤ 0,23	m.c.a.	20	25	13,5
EVOPLUS D 60/220.32 M	220	DN 32 PN 6	220/240 V	110	0,75	EEI ≤ 0,23	m.c.a.	20	25	13,5

Liquid temperature range: da -10°C a +110°C - Maximum operating pressure: 16 bar (1600 kPa)

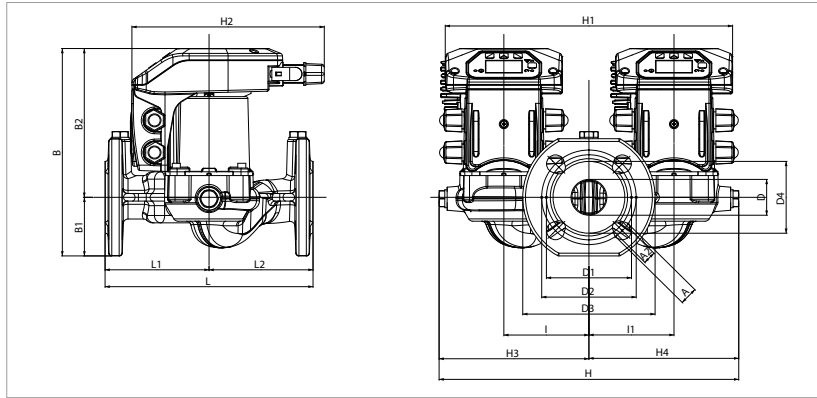

L	L1	L2	A	A2	B	B1	B2	D	D1
220	110	110	19	14	220	62	158	40	90

D2	D3	D4	I	I1	H	H1	H2	H3	H4
100	140	76	90	90	300	304	204	150	150

The performance curves are based on kinematic viscosity values = 1 mm²/s and density equivalent to 1000 kg/m³. Tolerance of curves to ISO 9906. Constant curve available on DNA.

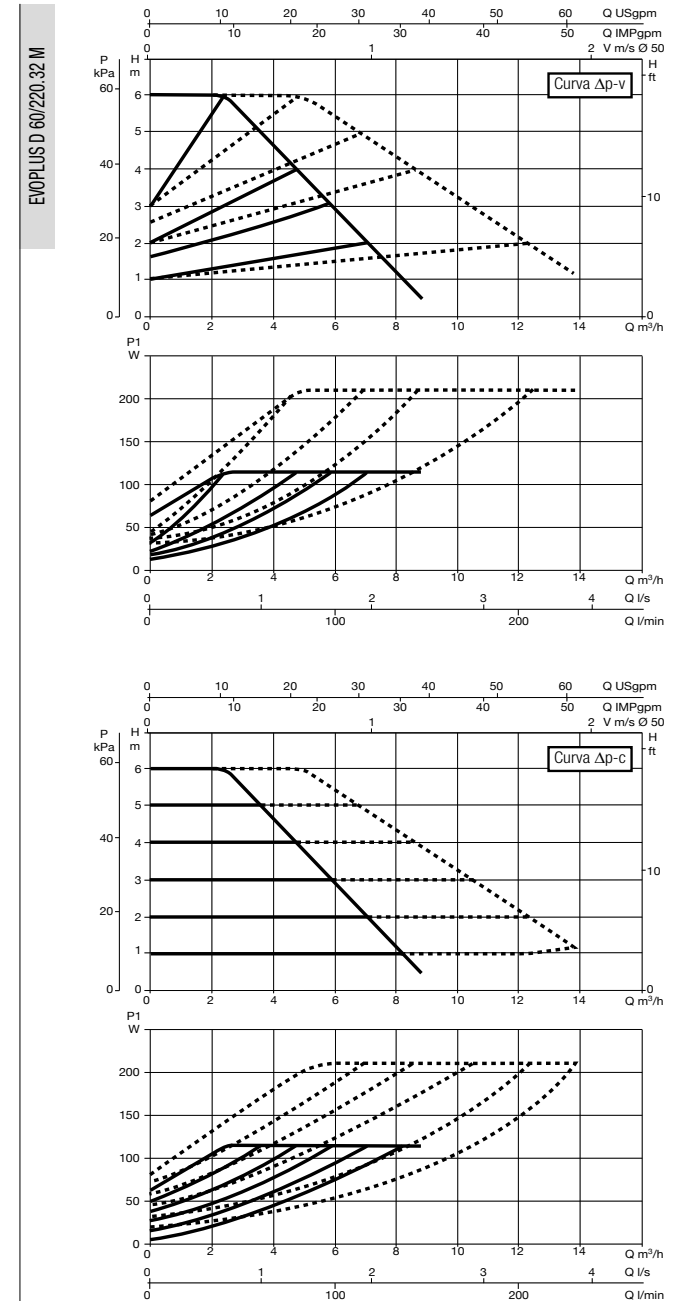
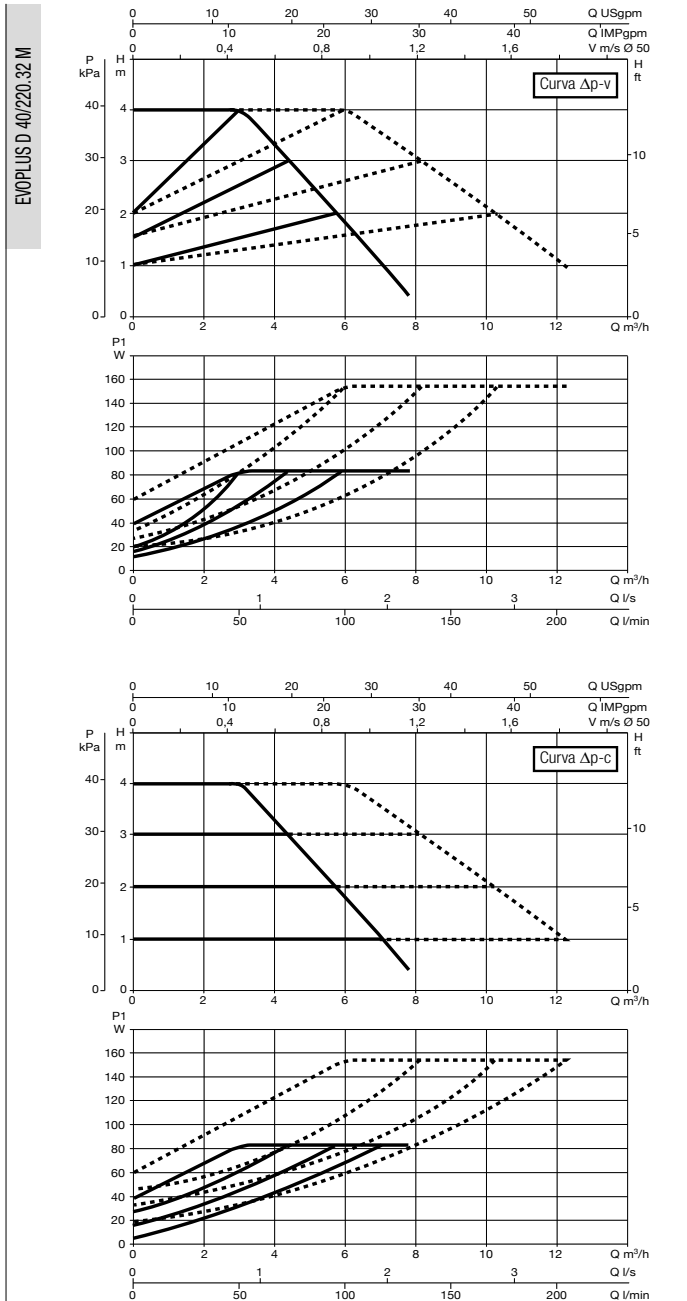

EVOPLUS SMALL - ELECTRONIC CIRCULATORS FOR HEATING AND AIR-CONDITIONING SYSTEMS

MODEL	CENTRE DISTANCE mm	COUNTERFLANGES ON REQUEST	VOLTAGE 50/60 Hz	P1 MAX W	In A	EEI	MINIMUM HEAD PRESSURE			WEIGHT Kg
							t°	90°	100°	
EVOPLUS D 80/220.32 M	220	DN 32 PN 6	220/240 V	150	0,95	EEI ≤ 0,23	m.c.a.	20	25	13,5
EVOPLUS D110/220.32 M	220	DN 32 PN 6	220/240 V	200	1,3	EEI ≤ 0,23	m.c.a.	20	25	13,5

Liquid temperature range: da -10°C a +110°C - Maximum operating pressure: 16 bar (1600 kPa)

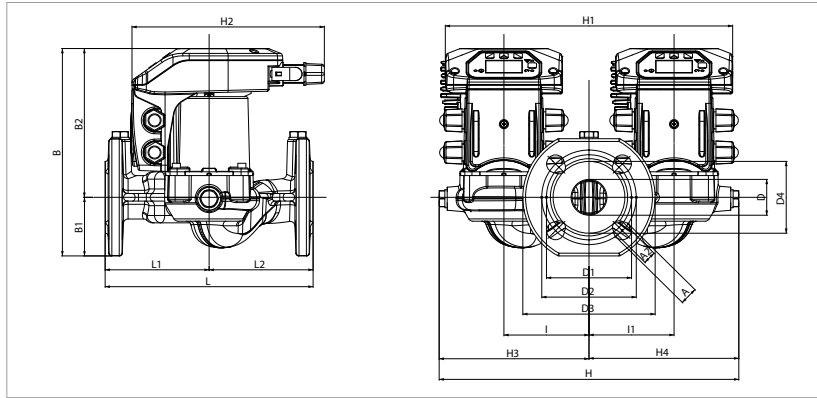

L	L1	L2	A	A2	B	B1	B2	D	D1
220	110	110	19	14	220	62	158	40	90

D2	D3	D4	I	I1	H	H1	H2	H3	H4
100	140	76	90	90	300	304	204	150	150

The performance curves are based on kinematic viscosity values = 1 mm²/s and density equivalent to 1000 kg/m³. Tolerance of curves to ISO 9906. Constant curve available on DNA.

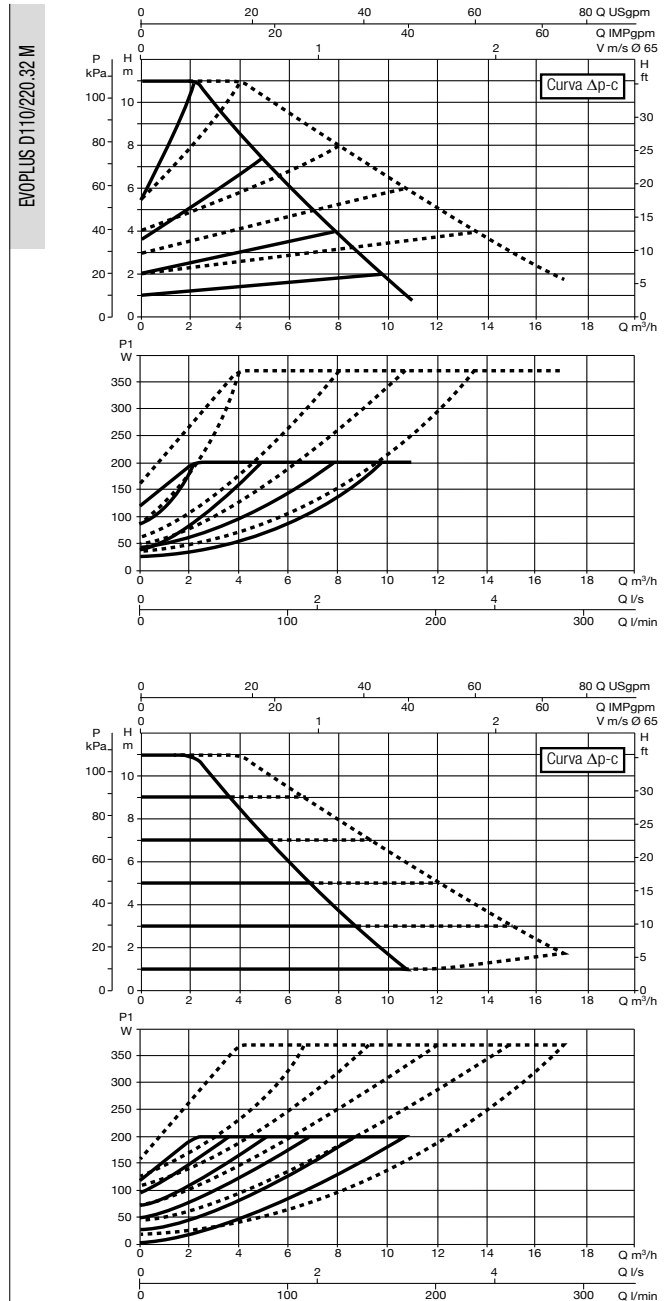
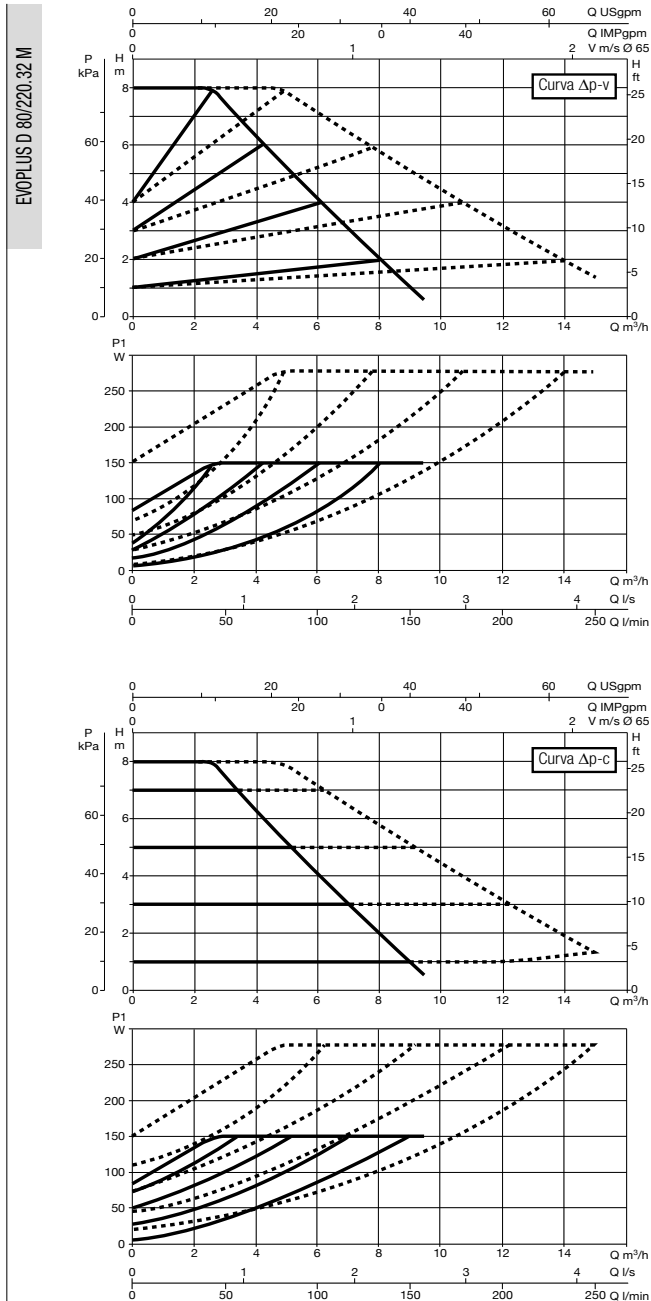

EVOPLUS SMALL - ELECTRONIC CIRCULATORS FOR HEATING AND AIR-CONDITIONING SYSTEMS

MODEL	CENTRE DISTANCE mm	COUNTERFLANGES ON REQUEST	VOLTAGE 50/60 Hz	P1 MAX W	In A	EEI	MINIMUM HEAD PRESSURE			WEIGHT Kg
							t°	90°	100°	
EVOPLUS D 40/250.40 M	250	DN 40 PN 10	220/240 V	75	0,55	EEI ≤ 0,22	m.c.a.	20	25	14,2
EVOPLUS D 60/250.40 M	250	DN 40 PN 10	220/240 V	100	0,75	EEI ≤ 0,22	m.c.a.	20	25	14,2

Liquid temperature range: da -10°C a +110°C - Maximum operating pressure: 16 bar (1600 kPa)

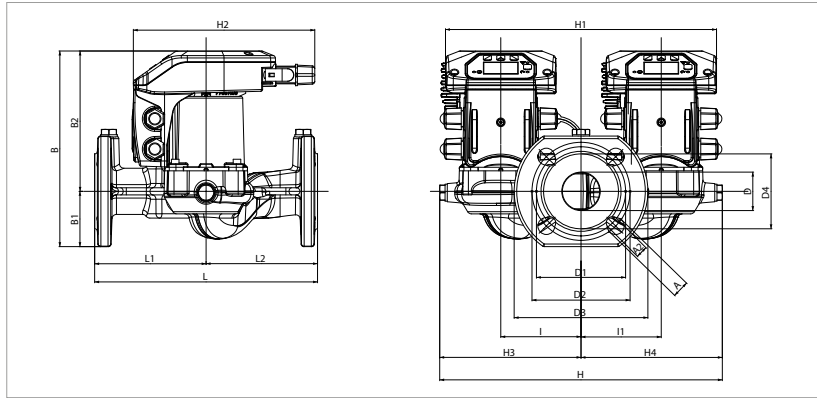

L	L1	L2	A	A2	B	B1	B2	D	D1
250	125	125	19	14	220	62	158	43	100

D2	D3	D4	I	I1	H	H1	H2	H3	H4
110	150	84	90	90	300	304	204	150	150

The performance curves are based on kinematic viscosity values = 1 mm²/s and density equivalent to 1000 kg/m³. Tolerance of curves to ISO 9906. Constant curve available on DNA.

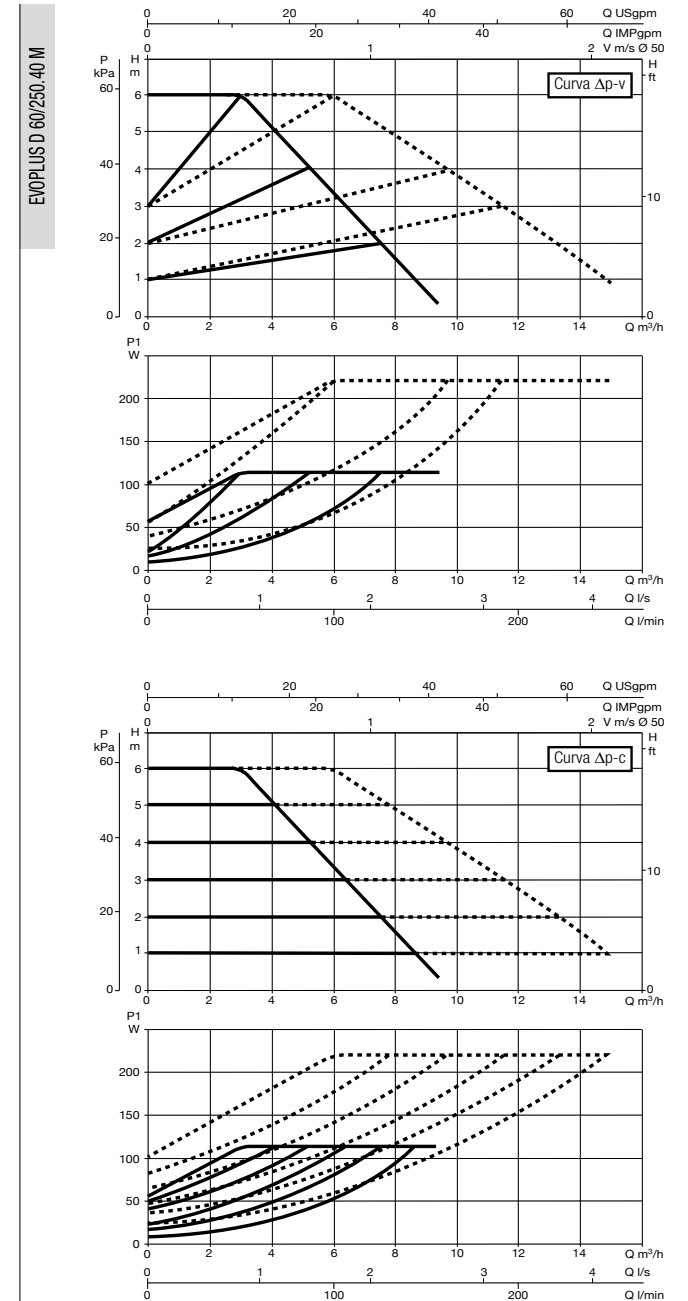
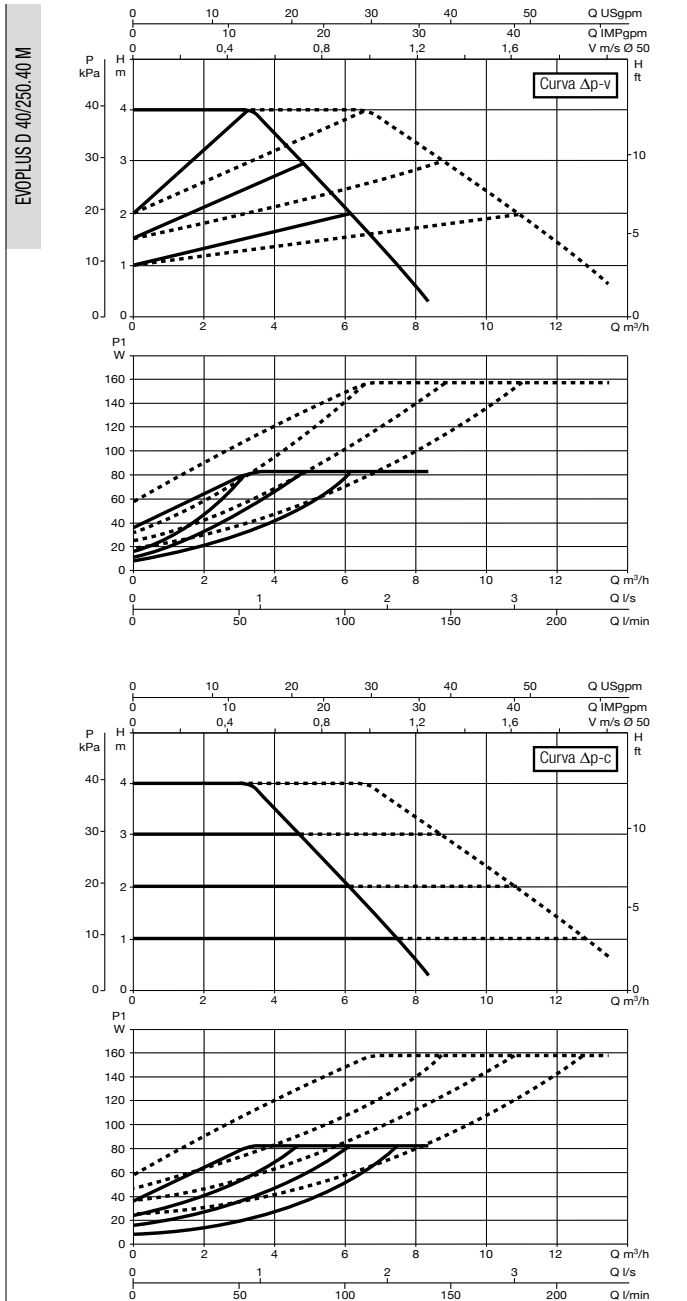

EVOPLUS SMALL - ELECTRONIC CIRCULATORS FOR HEATING AND AIR-CONDITIONING SYSTEMS

MODEL	CENTRE DISTANCE mm	COUNTERFLANGES ON REQUEST	VOLTAGE 50/60 Hz	P1 MAX W	In A	EEI	MINIMUM HEAD PRESSURE			WEIGHT Kg
							t°	90°	100°	
EVOPLUS D 80/250.40 M	250	DN 40 PN 10	220/240 V	135	0,95	EEI ≤ 0,22	m.c.a.	20	25	14,2
EVOPLUS D110/250.40 M	250	DN 40 PN 10	220/240 V	190	1,3	EEI ≤ 0,22	m.c.a.	20	25	14,2

Liquid temperature range: da -10°C a +110°C - Maximum operating pressure: 16 bar (1600 kPa)

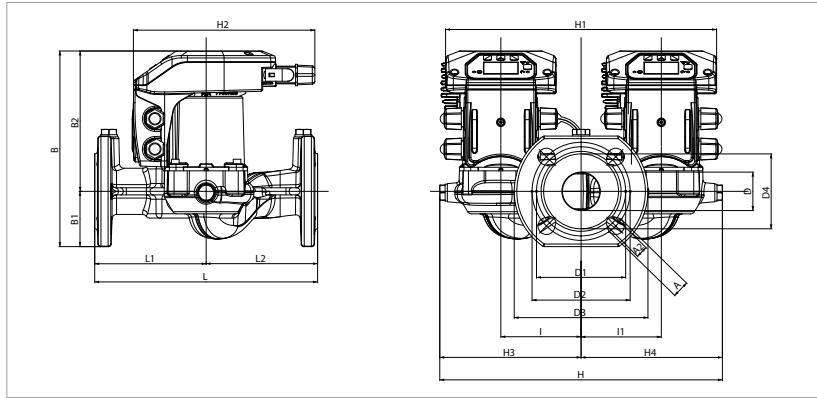

L	L1	L2	A	A2	B	B1	B2	D	D1
250	125	125	19	14	220	62	158	43	100

D2	D3	D4	I	I1	H	H1	H2	H3	H4
110	150	84	90	90	300	304	204	150	150

The performance curves are based on kinematic viscosity values = 1 mm²/s and density equivalent to 1000 kg/m³. Tolerance of curves to ISO 9906. Constant curve available on DNA.

