

Customer	Date	12/9/2020
Contact	Project	
Phone number	Project no.	
Email		

## ESHE 32-250/75/P25VSSA

101860230

### Operating data

Pump type	Single head pump	Fluid	Water, pure
No. of pumps / Reserve	1 / 0	Operating temperature t A	°C 4
Nominal flow	l/s 0	pH-value at t A	7
Nominal head	m 0	Density at t A	kg/m <sup>3</sup> 1000
Static head	m 0	Kin. viscosity at t A	mm <sup>2</sup> /s 1.569
Inlet pressure	kPa 0	Vapor pressure at t A	kPa 100
Environmental temperature	°C 20	Solids	0
Available system NPSH	m 0	Altitude	m 0

### Pump data

Make	Lowara	Nominal	l/s ( )
Speed	rpm 2900	Flow Max-	l/s 7.5
Number of stages	1	Min-	l/s 2.2
Max. casing pressure	kPa	Nominal	m
Max. working pressure	kPa 652.2	Head at Qmax	m 48.8
Head H(Q=0)	m 66	at Qmin	m 65.2
Weight	kg	Shaft power	kW ( )
Impeller R	Max. mm 244	Max. shaft power	kW 7.1
	designed mm 223	Efficiency	%
	Min. mm 203	NPSH 3%	m
Suction nozzle	DN 50 PN 12 EN1092-2 (e-SH)	Discharge nozzle	DN 32 PN 12 EN1092-2 (e-SH)

### Pump Materials

Pump body	Stainless steel / AISI 316L
Impeller	Stainless steel / AISI 316L
SEAL HOUSING	Stainless steel / AISI 316L
Wear Ring	Stainless steel / AISI 316L
Counterwear ring	Stainless steel / AISI 316L
Shaft extension	Stainless steel / AISI 316L
Rigid shaft coupling	Stainless steel / AISI 316
Impeller locknut and washer	Stainless steel / AISI 316
Tab	Stainless steel / AISI 316L

### Shaft Seal

Single Seal	
e-SH - uniten	Roten
Rotating Assembly	V-Ceramic
Fixed Assembly	B-Resin impregnated carbon
Elastomers	V-FKM (FPM)
Springs	G-AISI 316
Other Components	G-AISI 316

### Motor data

Manufacturer	Lowara	Electric voltage	400 V
Specific design	IE3 Three phase surface motor		
Type	PLM132.../375 E3		
Rated power	7.5 kW	Electric current	14.1 A
Speed	2935 rpm	Degree of protection	IP 55
Frame size	132	Weight	57 kg
Shaft diameter	0 mm	Colour	RAL 5010
Insulation class	F		

### Coupling

Manufacturer	
Series	
Type	
Frame size	
Spacer length	
Weight	
Coupling protection	

### Base plate

Description	
Weight	

### Remarks:

Customer	Date	12/9/2020
Contact	Project	
Phone number	Project no.	
Email		

## ESHE 32-250/75/P25VSSA

### 101860230

#### Hydraulic data

Operating Data Specification		Hydraulic data (duty point)		Impeller design	
Flow	0 l/s	Flow		Impeller R	223 mm
Head	0 m	Head		Frequency	50 Hz
Static head	0 m	MEI $\geq 0,4$		Speed	2900 rpm

Power data referred to:  
 Water, pure [100%] ; 4°C; 1000kg/m<sup>3</sup>; 1.57mm<sup>2</sup>/s  
 Performance according to ISO 9906:2012 – Grade 3B

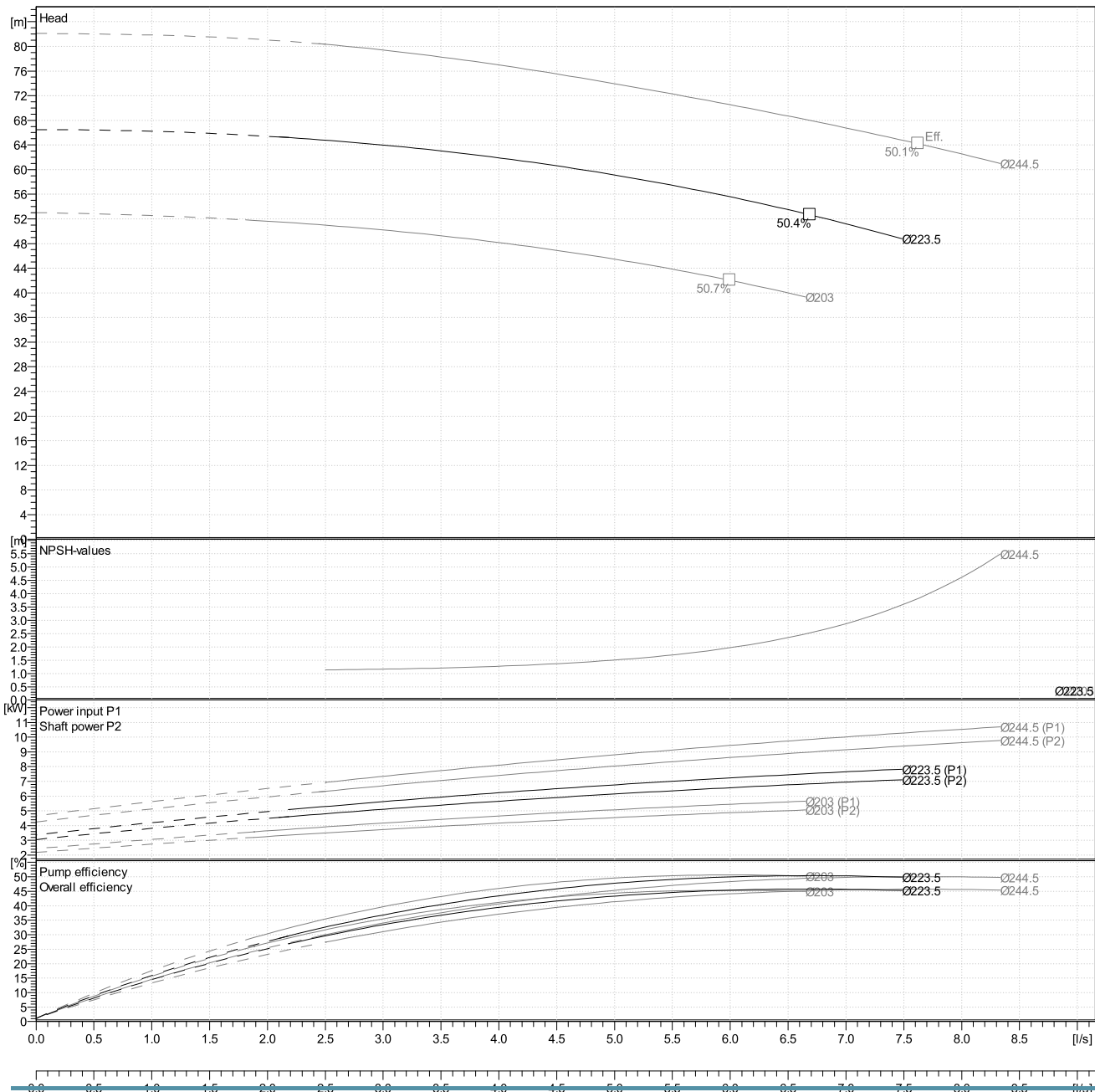

Customer	Date	12/9/2020
Contact	Project	
Phone number	Project no.	
Email		

**ESHE 32-250/75/P25VSSA**  
101860230

**Dimensions** mm/l

a	100		
B	345		
DNA	50		
DNM	32		
h1	180		
h2	225		
Hmax	405		
k	98		
L	567		
n	265		
n1	130		
w1	305		
x	191		
		Total weight	84 kg

**Connections** mm

Suction nozzle	Discharge nozzle
DN 50	DN 32
PN 12	PN 12
EN1092-2 (e-SH)	EN1092-2 (e-SH)

D	165	D	140
Dia. Holes	18	Dia. Holes	18
DN	50	DN	32
G	83	G	64
M	125	M	100
Max thickness	18	Max thickness	16
N° Holes	4	N° Holes	4

**Drawing**

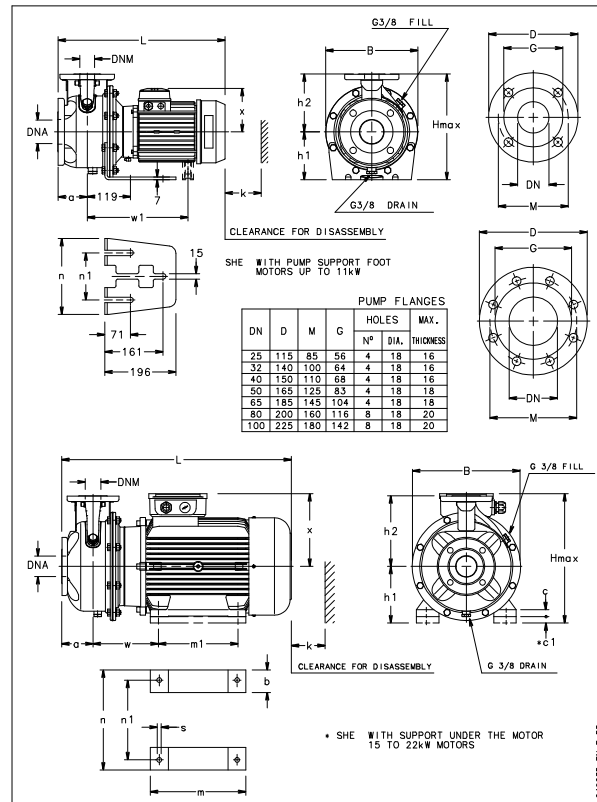

046035-EN-LE\_DB