

Pump data

Make	Lowara
Port to port (mm)	360
Electrical connection	Terminals
Specific EEI	<= 0,23
Nominal pressure	PN 10
Connection	Flanged / DN 100

Electrical data

Rated voltage	230 V
Frequency	50 / 60
Protection class	IP 44
Insulation class	F
Digital input	Contact load: 5V, 10 mA
Digital output	Vmax < 250 VAC / Imax < 2 A
Analog input	0-10 V / 4-20 mA
Leakage current	< 3.5 mA
Communication capabilities	Modbus RTU & BACnet MS/TP
Sound pressure level	<= 55 dB(A)
Rated current	6.6 A

Materials

Bush Bearing	Carbon, resin impregnated	Impeller	PPS
Thrust bearing	Aluminium	Wear Ring	Stainless steel
Bearing plate	Stainless steel	Rotor can	Stainless steel
Motor housing	Aluminum	Shaft	Stainless steel
O-rings	EPDM	Control box	Poly carbonate
PUMP HOUSING	Cast Iron		

Dimensions mm

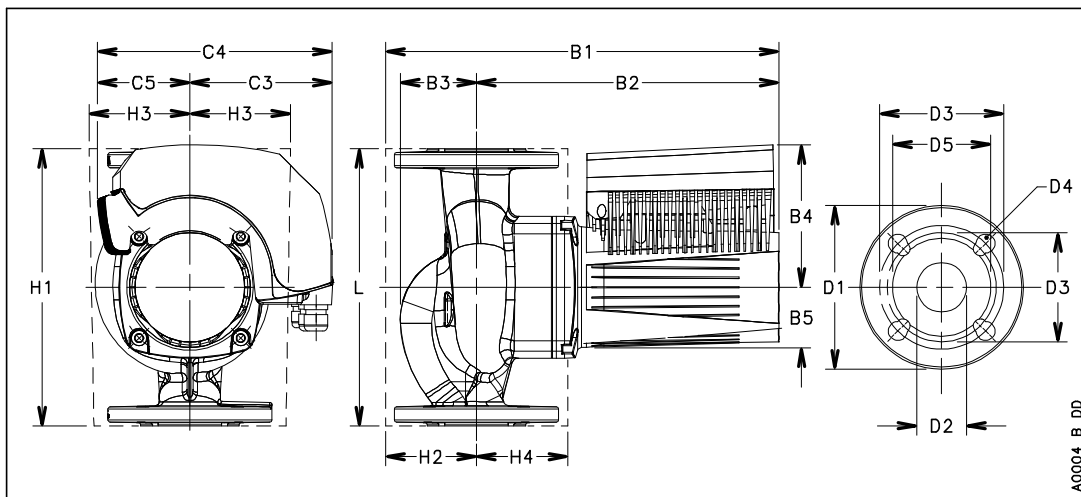

B1	403
B2	306
B3	97
B4	147
B5	60
C3	148
C4	241
C5	93
D1	220
D2	100
D3	180
D4	8 x 19
D5	156
G	DN 100
Gross Weight	31.6
H1	360
H2	120
H3	120
H4	120
L	360
Net Weight	26.2