

Performance according to ISO 9906:2012 – Grade 3B

Liquid temperature:

Power data referred to:

Water, pure [100%]; 4°C; 1000kg/m³; 1.57mm²/s

-10°C (14°F) to +110 °C (230°F) for heating pumps

-10°C (14°F) to +85 °C (185°F) for domestic hot water pumps



Pump data

Make	Lowara
Port to port (mm)	220
Electrical connection	Terminals
Specific EEI	<= 0,23
Nominal pressure	PN 6/10
Connection	Flanged / DN 40

Electrical data

Rated voltage	230 V
Frequency	50 / 60
Protection class	IP 44
Insulation class	F
Digital input	Contact load: 5V, 10 mA
Digital output	Vmax < 250 VAC / Imax < 2 A
Analog input	0-10 V / 4-20 mA
Leakage current	< 3.5 mA
Communication capabilities	Modbus RTU & BACnet MS/TP
Sound pressure level	<= 48 dB(A)
Rated current	1.4 A

Materials

Bush Bearing	Carbon, resin impregnated	Impeller	PPS
Thrust bearing	Aluminium	Wear Ring	Stainless steel
Bearing plate	Stainless steel	Rotor can	Stainless steel
Motor housing	Aluminum	Shaft	Stainless steel
O-rings	EPDM	Control box	Poly carbonate
PUMP HOUSING	Cast Iron		

Dimensions mm

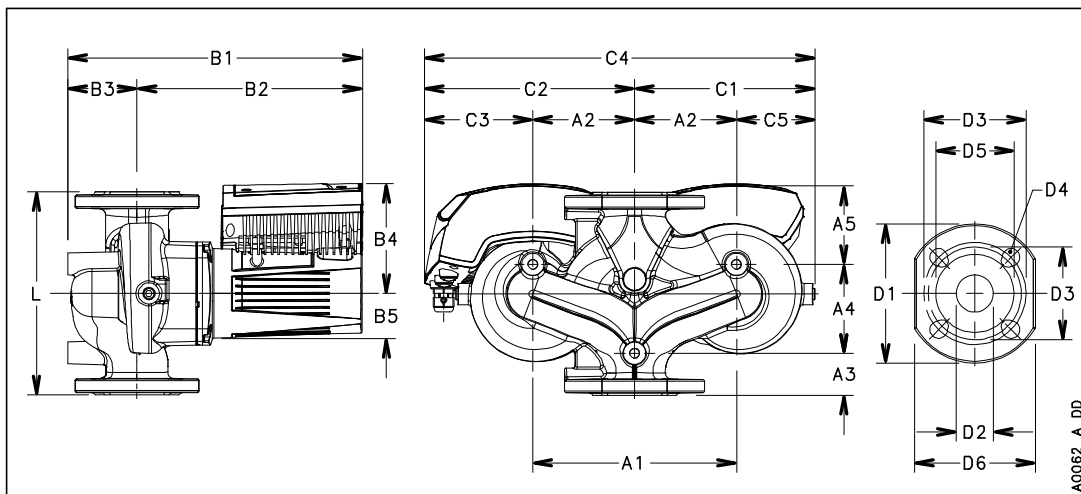

A1	215
A2	107.5
A3	45
A4	95
A5	80
B1	330
B2	259
B3	71
B4	130
B5	51
C1	186
C2	235
C3	128
C4	421
C5	79
D1	150
D2	45
D3	100/110
D4	4 x 14/19
D5	84
G	DN 40
Gross Weight	35.3