



Pump data

| | |
|-----------------------|-----------------|
| Make | Lowara |
| Port to port (mm) | 250 |
| Electrical connection | Terminals |
| Specific EEI | <= 0,23 |
| Nominal pressure | PN 6/10 |
| Connection | Flanged / DN 40 |

Electrical data

| | |
|----------------------------|-----------------------------|
| Rated voltage | 230 V |
| Frequency | 50 / 60 |
| Protection class | IP 44 |
| Insulation class | F |
| Digital input | Contact load: 5V, 10 mA |
| Digital output | Vmax < 250 VAC / Imax < 2 A |
| Analog input | 0-10 V / 4-20 mA |
| Leakage current | < 3.5 mA |
| Communication capabilities | Modbus RTU & BACnet MS/TP |
| Sound pressure level | <= 52 dB(A) |
| Rated current | 2.9 A |

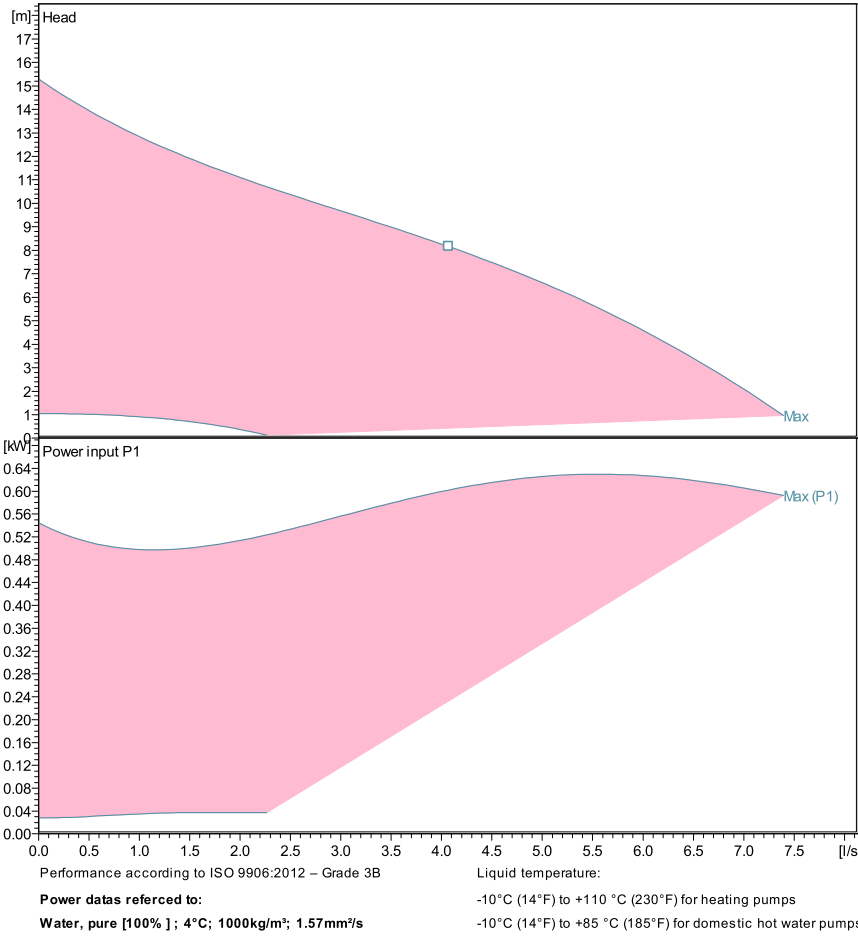

Materials

| | | | |
|----------------|---------------------------|-------------|-----------------|
| Bush Bearing | Carbon, resin impregnated | Impeller | PPS |
| Thrust bearing | Aluminium | Wear Ring | Stainless steel |
| Bearing plate | Stainless steel | Rotor can | Stainless steel |
| Motor housing | Aluminum | Shaft | Stainless steel |
| O-rings | EPDM | Control box | Poly carbonate |
| PUMP HOUSING | Cast Iron | | |

Dimensions mm

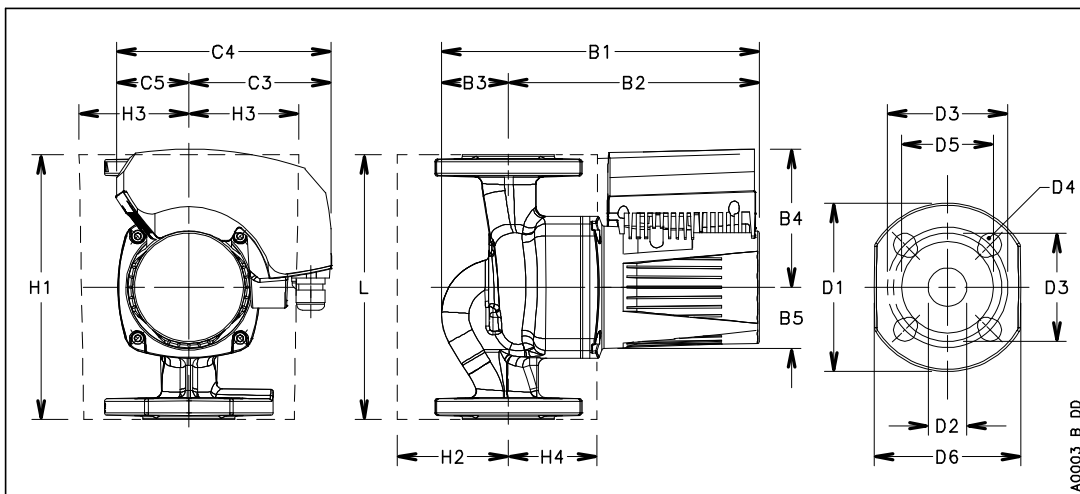

| | |
|--------------|-----------|
| B1 | 365 |
| B2 | 299 |
| B3 | 66 |
| B4 | 147 |
| B5 | 61 |
| C3 | 146 |
| C4 | 239 |
| C5 | 93 |
| D1 | 150 |
| D2 | 40 |
| D3 | 100/110 |
| D4 | 4 x 14/19 |
| D5 | 84 |
| G | DN 40 |
| Gross Weight | 21.6 |
| H1 | 240 |
| H2 | 86 |
| H3 | 90/102 |
| H4 | 93 |
| L | 250 |
| Net Weight | 17.8 |