



water solutions

# Data sheet

## DRY 750/2/80 A0HT5

# Y

series

### Technical specification

3~ 50 Hz

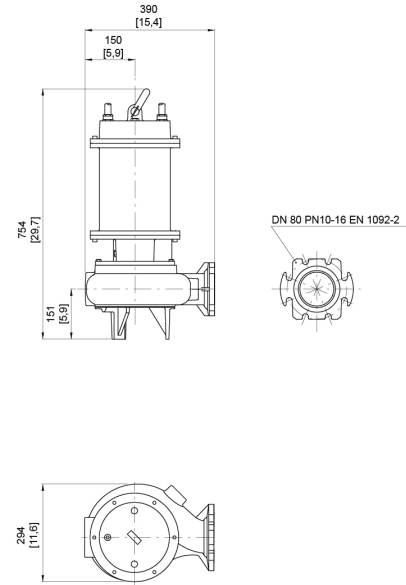
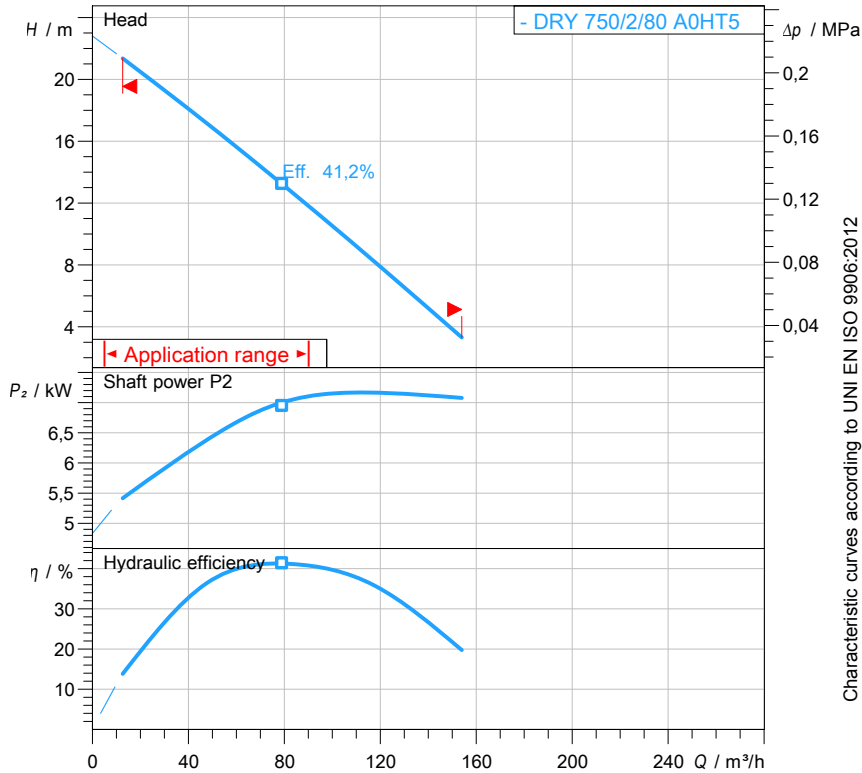

[ mm ]  
[ inch ]

#### Pump

Series	Y series
Pump name	DRY 750/2/80 A0HT5
Configuration	NYTAC81040N00NN
Standard	EN 809:2009

#### Motor data

Rated voltage	400 V
Frequency	50 Hz
Motor phases	3~
Number of poles	2
Rated power P2	7,20 kW
Incoming power P1	8,80 kW
Rated current	14,5 A
rpm	2850 1/min
Efficiency	83,7 %
cos φ	0,88
Rated torque	24,1 Nm
Start	Star-delta
Degree of protection	IP 68
Insulation class	H

#### Hydraulic

Type	DR (Multi-channel open)
Free passage	63 mm
Impeller type	Multi channel impeller
Max. hydraulic efficiency	41,2 %
Suction	-
Discharge	DN 80 EN 1092-2
Curve tolerance	UNI EN ISO 9906:2012

#### Operating limits (standard pumps)

Max. ambient temperature	40 °C
Max. density treated liquid	1100 kg/m³
Max. immersion depth	30 m
pH treated liquid	3 ÷ 14
Max. start per hour (equally distributed)	35
Wet/dry use	WET
Max. acoustic pressure level	70 dB
Operating mode	S1 - Continuous use

#### Construction materials

Case	AISI 316
Shaft	Stainless steel - AISI 420
Hydraulic	AISI 316
Impeller	AISI 316
Screws	Stainless steel - Class A4-70
Gaskets	VITON
Foot base	AISI 316

#### Construction features

Main cable	2 x 4G2.5
Control cable	2G1
Cable length	10 mt
Mechanical seals	2 in silicon carbide (SiC) and 1 in alumina graphite (AL)
Additional drilling	-
Weight*	104 kg
Electrical variant	Thermal protection

\* cable's weight not included



water solutions

# Data sheet DRY 750/2/80 A0HT5

# Y series

## Pump performance curves

3~ 50 Hz

Hydraulic type DR (Multi-channel open)	Impeller type Multi channel impeller	Free passage 63 mm	Discharge DN 80	Suction -	
<b>DUTY POINT</b>					
Flow	Head	Shaft power P2	Hydraulic efficiency	Density 998,3 kg/m <sup>3</sup>	Viscosity 1,005 mm <sup>2</sup> /s

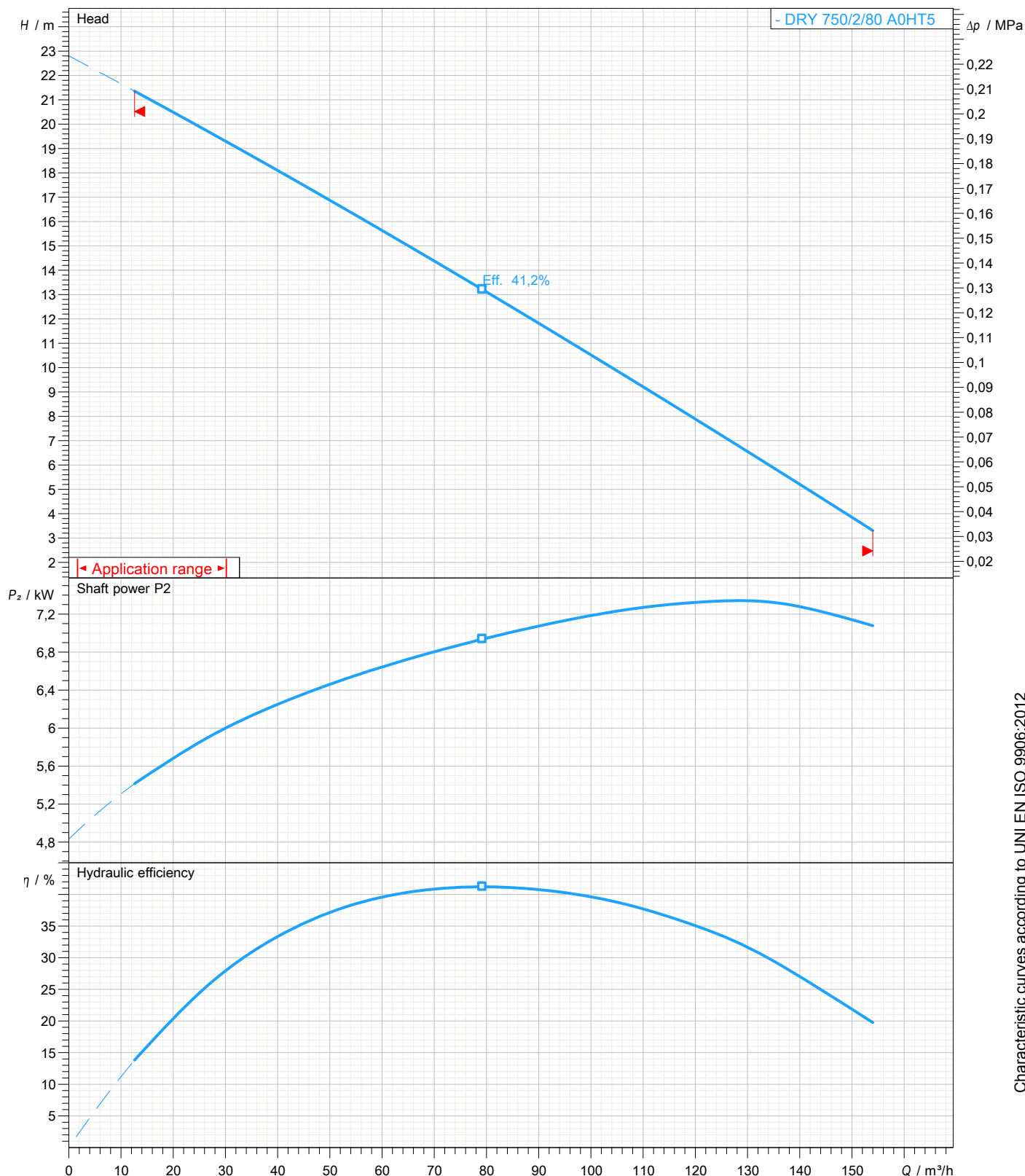

Characteristic curves according to UNI EN ISO 9906:2012



water solutions

# Data sheet DRY 750/2/80 A0HT5

# Y series

## Dimensional drawing

3~ 50 Hz

**Installation type** Installation with bottom coupling device - Vertical outlet

WET/DRY use: WET

Discharge: DN 80 EN 1092-2

Suction: -

Pressure rating (suction/discharge): PN 10

Accessory \* : DAC 80/80V[XX]+KAF 2"[XX] EN (P)

Accessory code \* : 9001.029

\* Accessory must be ordered separately

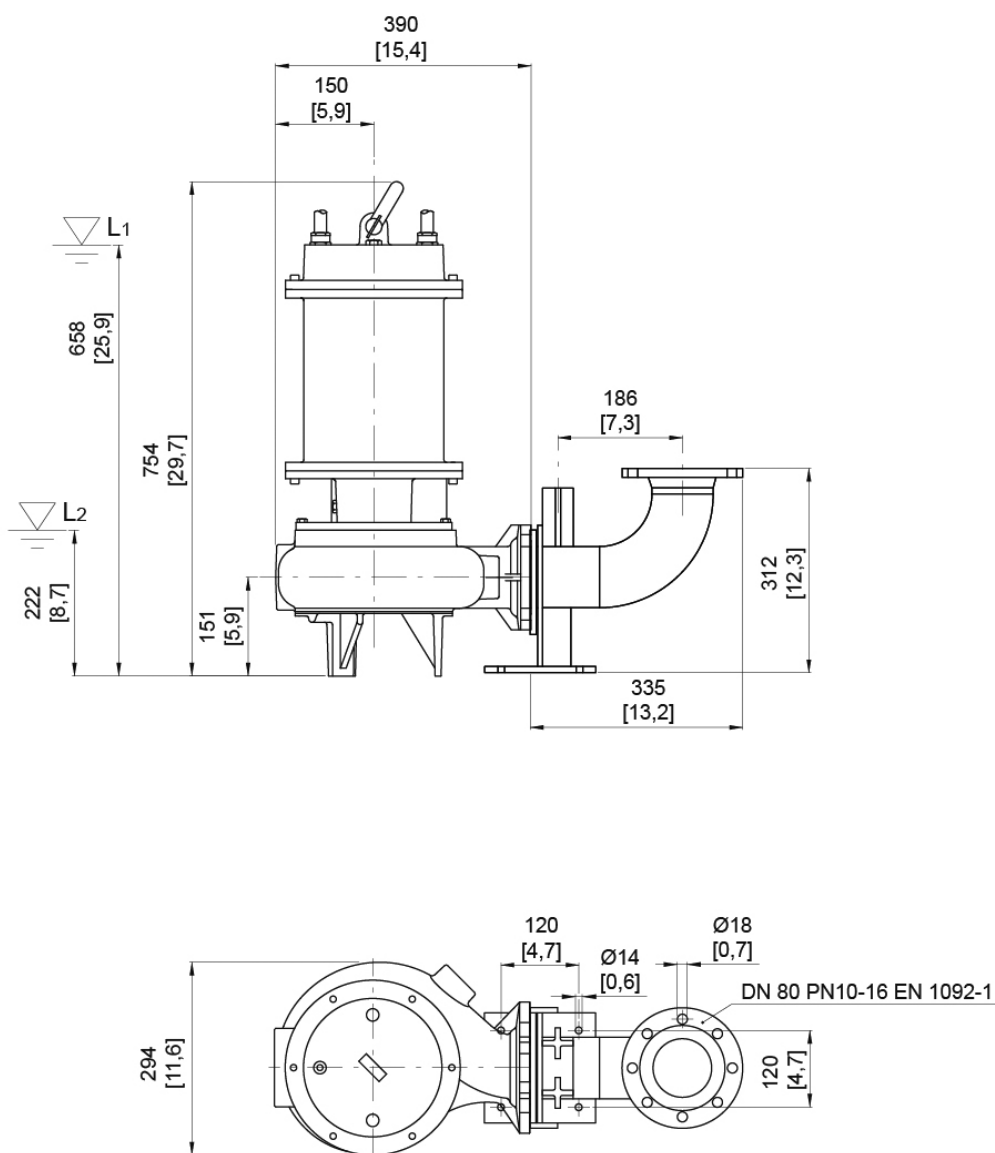

L1: Minimum operating level for continuous use  
L2: Minimum operating level for discontinuous use

[ mm ]  
[ inch ]