



water solutions

Data sheet

DRY 550/2/80 A0GT5

Y
series

Technical specification

3~ 50 Hz

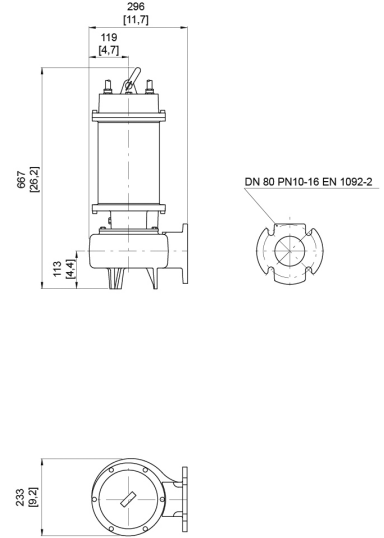
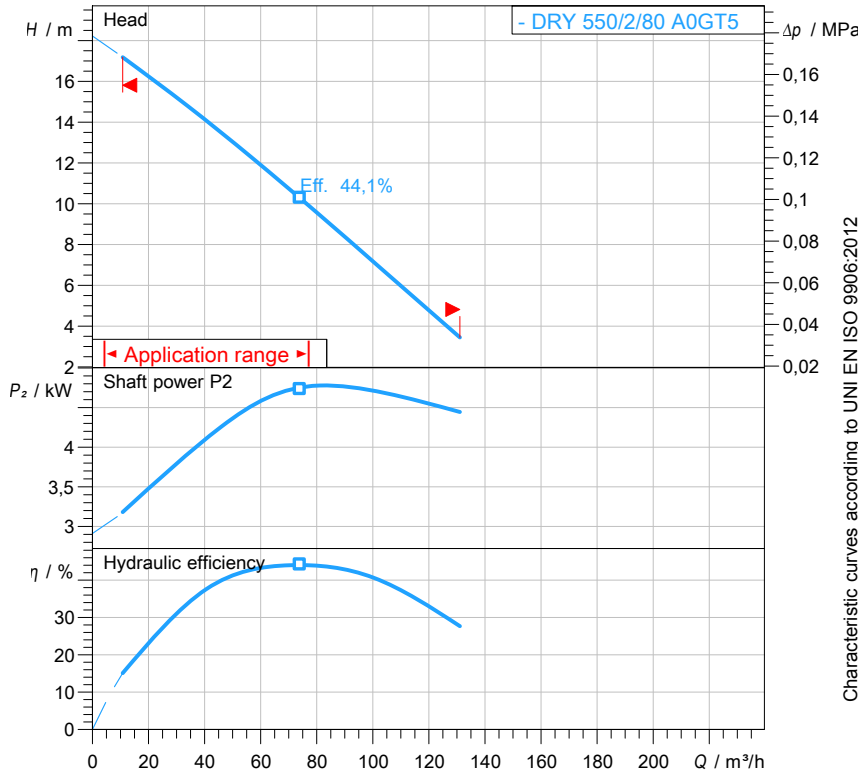

[mm]
[inch]

Pump

Series	Y series
Pump name	DRY 550/2/80 A0GT5
Configuration	NYTAC81040N00NN
Standard	EN 809:2009

Motor data

Rated voltage	400 V
Frequency	50 Hz
Motor phases	3~
Number of poles	2
Rated power P2	4,90 kW
Incoming power P1	5,90 kW
Rated current	10,1 A
rpm	2850 1/min
Efficiency	80,0 %
cos φ	0,85
Rated torque	16,4 Nm
Start	Direct starting
Degree of protection	IP 68
Insulation class	H

Hydraulic

Type	DR (Multi-channel open)
Free passage	56 mm
Impeller type	Multi channel impeller
Max. hydraulic efficiency	44,1 %
Suction	-
Discharge	DN 80 EN 1092-2
Curve tolerance	UNI EN ISO 9906:2012

Operating limits (standard pumps)

Max. ambient temperature	40 °C
Max. density treated liquid	1100 kg/m ³
Max. immersion depth	30 m
pH treated liquid	3 ÷ 14
Max. start per hour (equally distributed)	30
Wet/dry use	WET
Max. acoustic pressure level	70 dB
Operating mode	S1 - Continuous use

Construction materials

Case	AISI 316
Shaft	Stainless steel - AISI 420
Hydraulic	AISI 316
Impeller	AISI 316
Screws	Stainless steel - Class A4-70
Gaskets	VITON
Foot base	AISI 316

Construction features

Main cable	4G2.5
Control cable	2G1
Cable length	10 mt
Mechanical seals	2 in silicon carbide (SiC) and 1 in alumina graphite (AL)
Additional drilling	-
Weight*	62 kg
Electrical variant	Thermal protection

* cable's weight not included



water solutions

Data sheet DRY 550/2/80 A0GT5

Y series

Pump performance curves

3~ 50 Hz

Hydraulic type DR (Multi-channel open)		Impeller type Multi channel impeller		Free passage 56 mm	Discharge DN 80	Suction -
DUTY POINT						
Flow	Head	Shaft power P2	Hydraulic efficiency	Density 998,3 kg/m ³	Viscosity 1,005 mm ² /s	

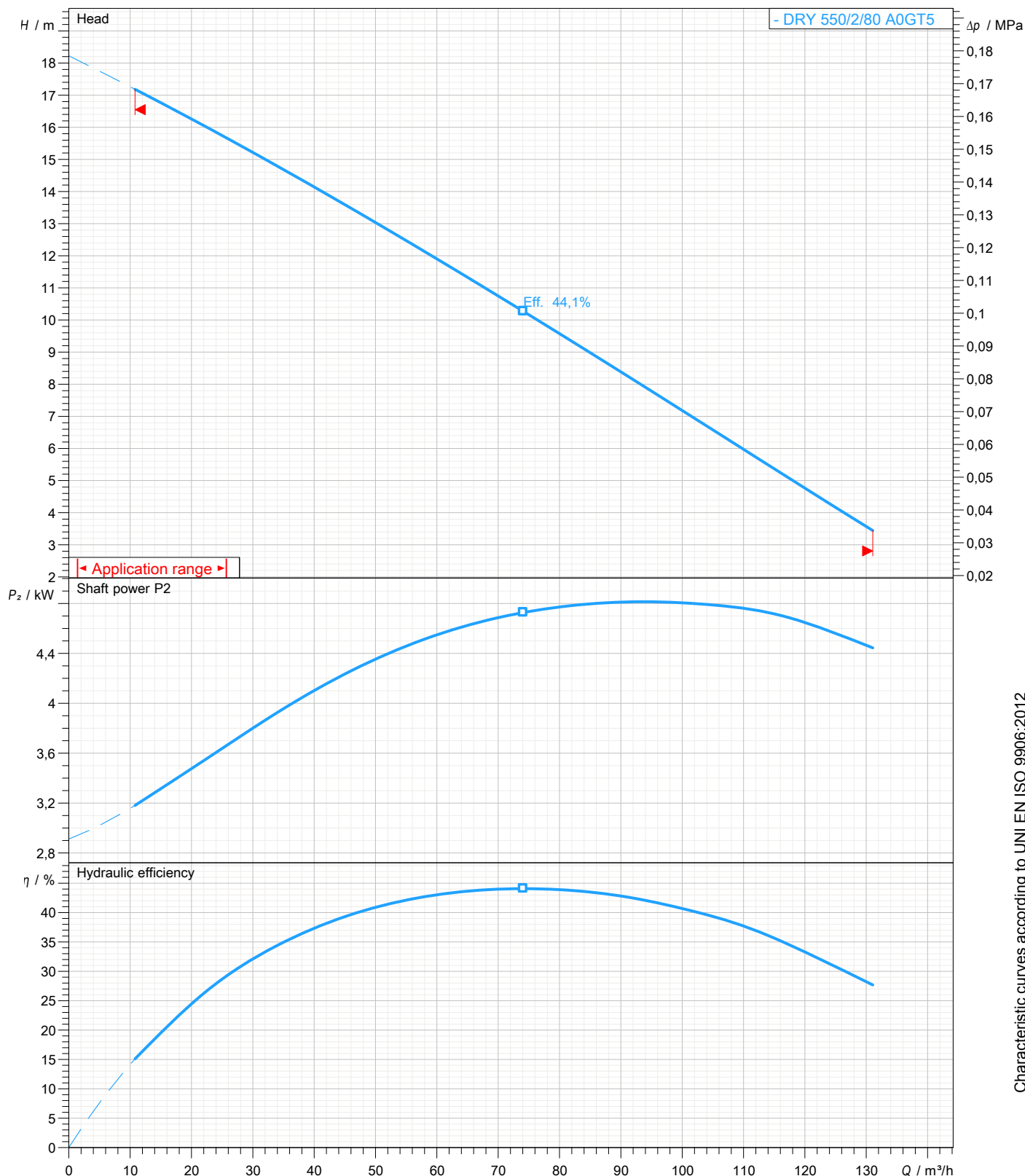

Characteristic curves according to UNI EN ISO 9906:2012



water solutions

Data sheet DRY 550/2/80 A0GT5

Y
series

Dimensional drawing

3~ 50 Hz

Installation type Installation with bottom coupling device - Vertical outlet

WET/DRY use: WET

Discharge: DN 80 EN 1092-2

Suction: -

Pressure rating (suction/discharge): PN 10

Accessory * : DAC 80/80V[XX]+KAF 2"[XX] EN (P)

Accessory code * : 9001.029

* Accessory must be ordered separately

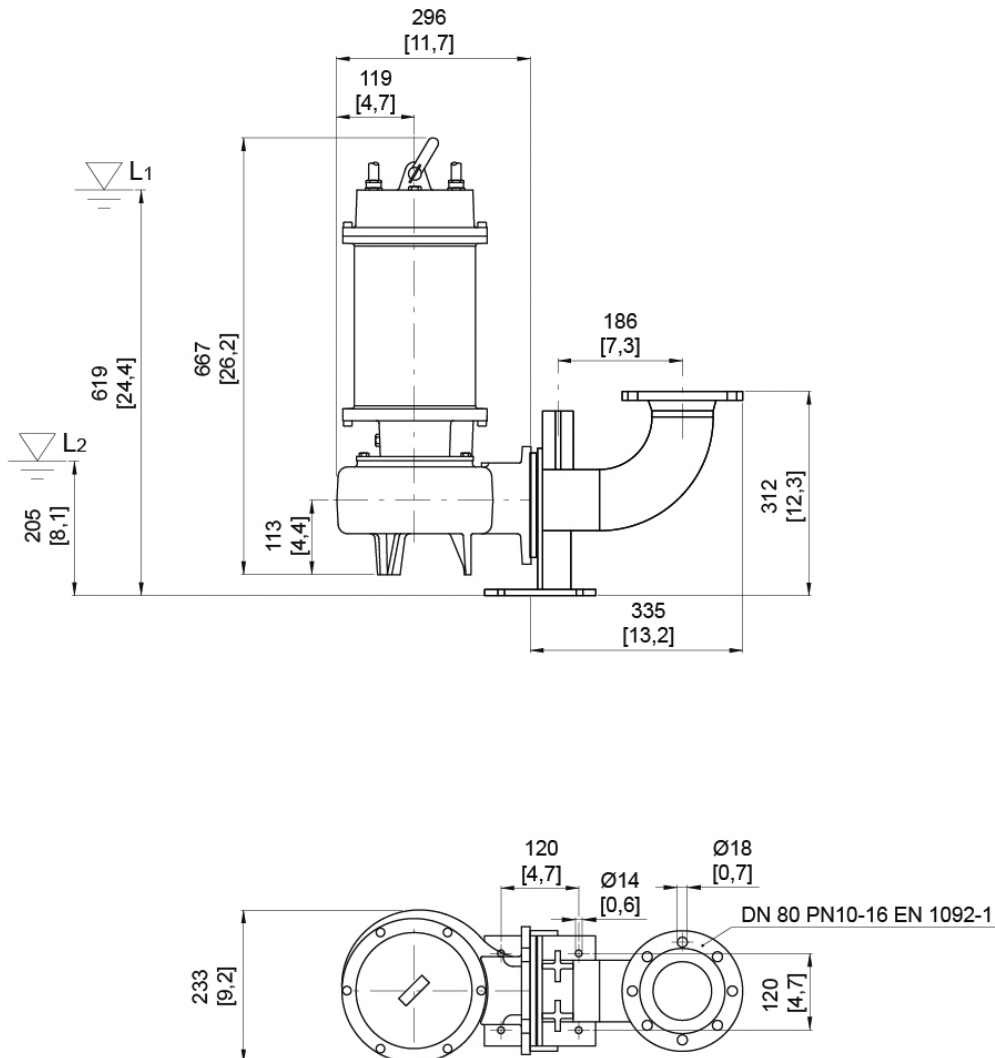

L1: Minimum operating level for continuous use
L2: Minimum operating level for discontinuous use

[mm]
[inch]