



water solutions

Data sheet

DG-Steel 37 M5

Steel
series

Technical specification

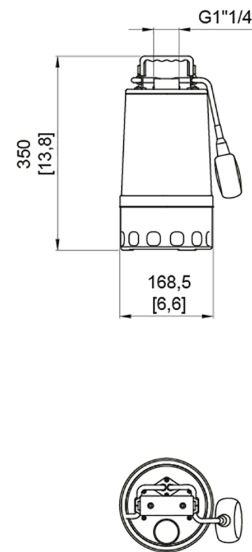
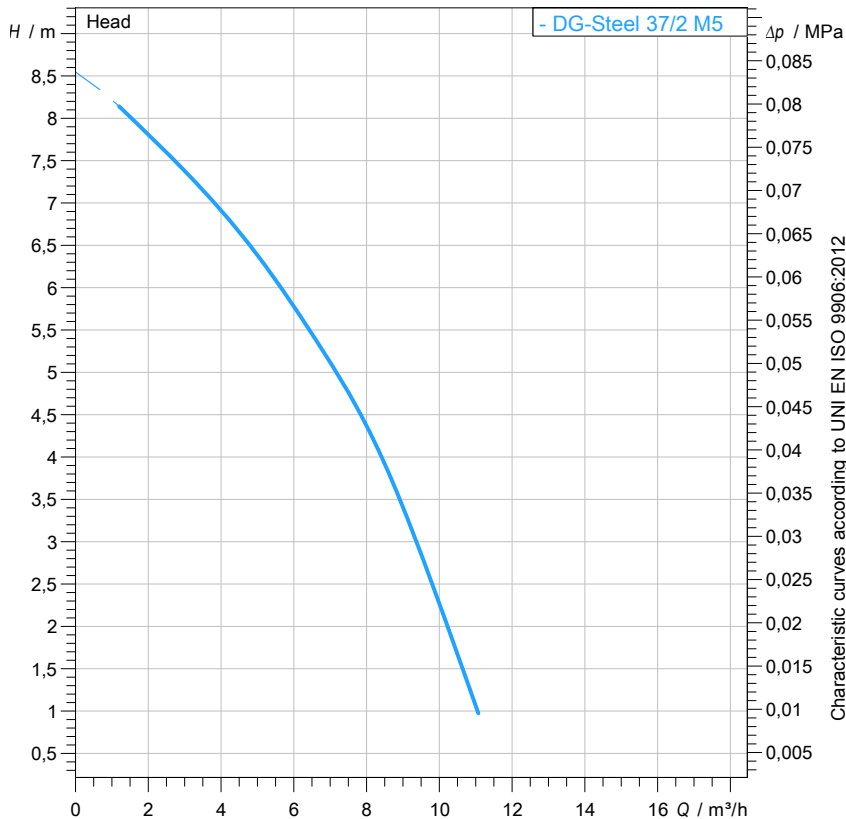
1~ 50 Hz

 [mm
[inch]]

Pump

Series	Steel series
Pump name	DG-Steel 37 M5
Configuration	0 TG5H2300NN
Standard	EN 809:2009

Motor data

Rated voltage	230 V
Frequency	50 Hz
Motor phases	1~
Number of poles	2
Rated power P2	0,37 kW
Incoming power P1	0,70 kW
Rated current	3,1 A
rpm	2730 1/min
Efficiency	55,6 %
cos φ	0,95
Rated torque	1,3 Nm
Start	
Degree of protection	IP 68
Insulation class	F

Hydraulic

Type	DG (Set-back Vortex)
Free passage	25 mm
Impeller type	Vortex impeller
Max. hydraulic efficiency	-
Suction	-
Discharge	G 1" 1/4 -
Curve tolerance	UNI EN ISO 9906:2012

Operating limits (standard pumps)

Max. ambient temperature	40 °C
Max. density treated liquid	1100 kg/m ³
Max. immersion depth	10 m
pH treated liquid	6 ÷ 14
Max. start per hour (equally distributed)	30
Wet/dry use	WET
Max. acoustic pressure level	70 dB
Operating mode	S1 - Continuous use

Construction materials

Case	Stainless steel - AISI 304
Shaft	Stainless steel AISI 431
Hydraulic	Stainless steel - AISI 304
Impeller	Stainless steel - AISI 304
Screws	Stainless steel - Class A2-70
Gaskets	NBR
Strainer	Stainless steel - AISI 304

Construction features

Main cable	3G1
Cable length	5 mt - Shuko plug
Mechanical seals	1 in silicon carbide (SiC) and 1 in alumina graphite (AL)
Weight*	6,6 kg
Electrical variant	Thermal protection, capacitor and float switch (on the motor cover)

* cable's weight not included



water solutions

Data sheet DG-Steel 37 M5

Steel
series

Pump performance curves

1~ 50 Hz

Hydraulic type DG (Set-back Vortex)		Impeller type Vortex impeller		Free passage 25 mm	Discharge G 1" 1/4	Suction -
DUTY POINT						
Flow	Head	Shaft power P2	Hydraulic efficiency	Density 998,3 kg/m ³	Viscosity 1,005 mm ² /s	

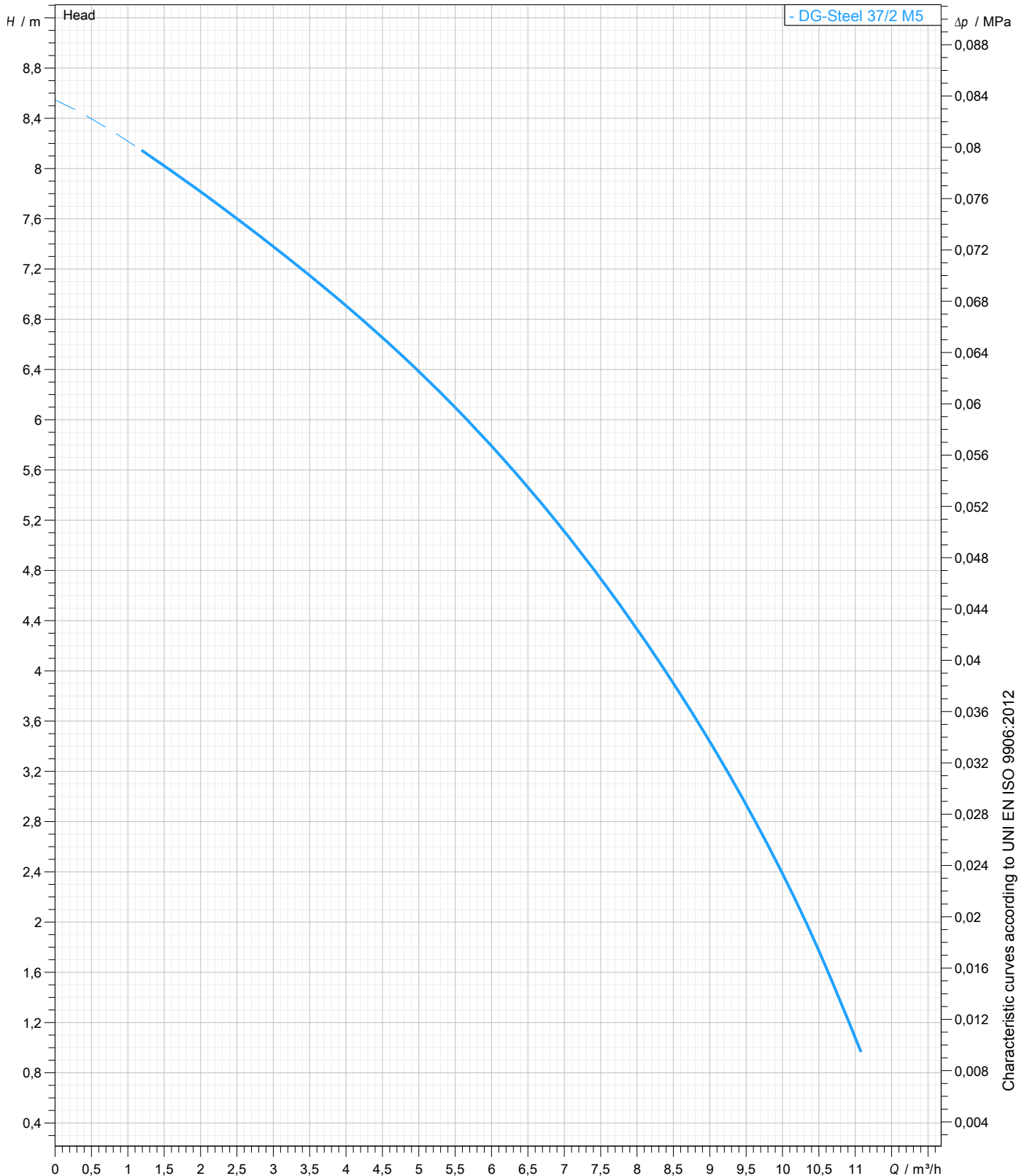



water solutions

Data sheet DG-Steel 37 M5

Steel
series

Dimensional drawing

1~ 50 Hz

Installation type Free Installation
WET/DRY use: WET
Discharge: G 1" 1/4 -
Pressure rating (suction/discharge): -

Suction: -

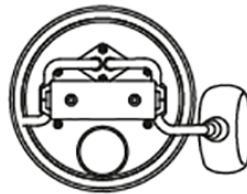
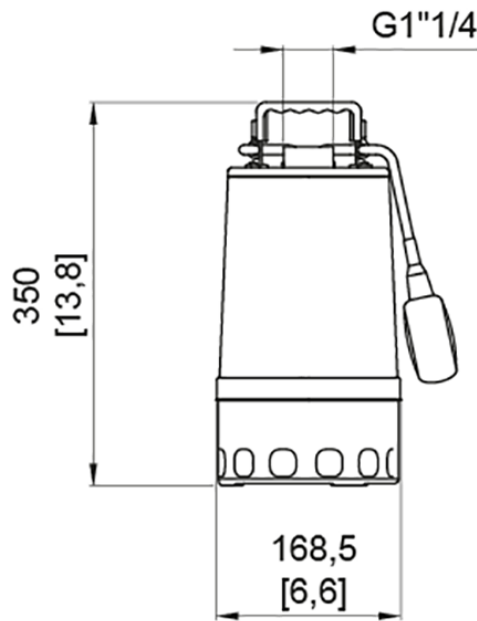

[mm]
[inch]