

DIMENSIONS AND WEIGHTS

NOVA 180

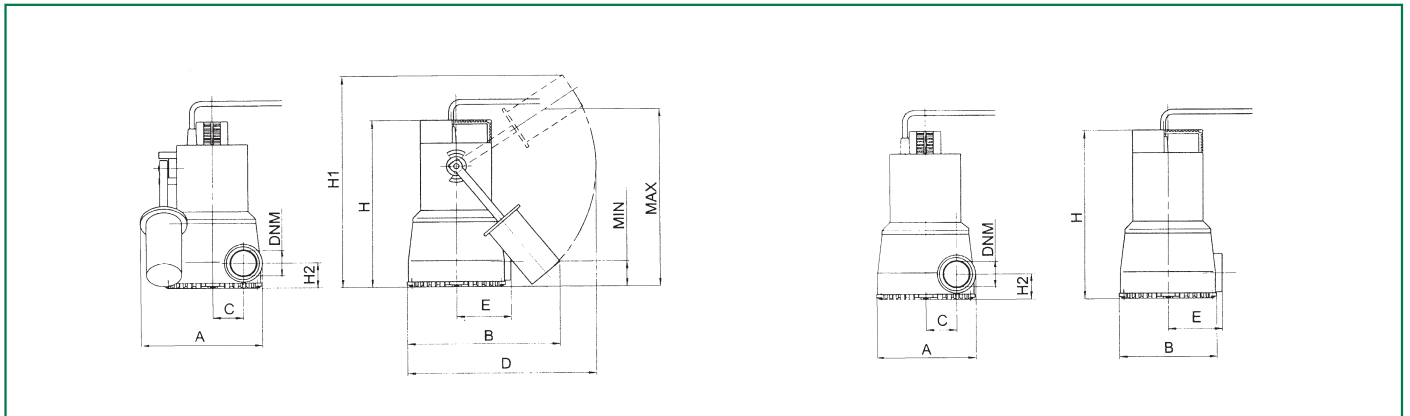

NOVA 200

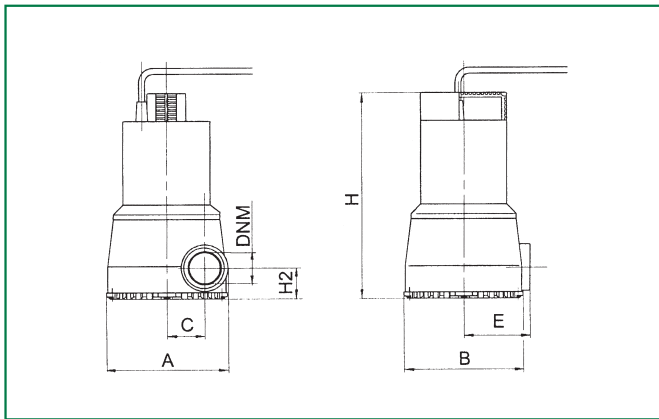

NOVA 300

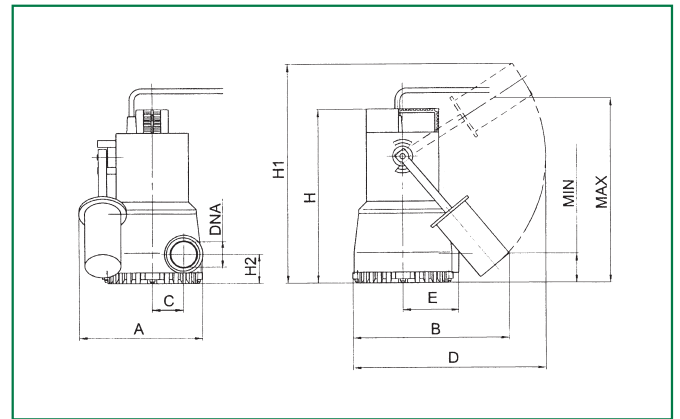

NOVA 600

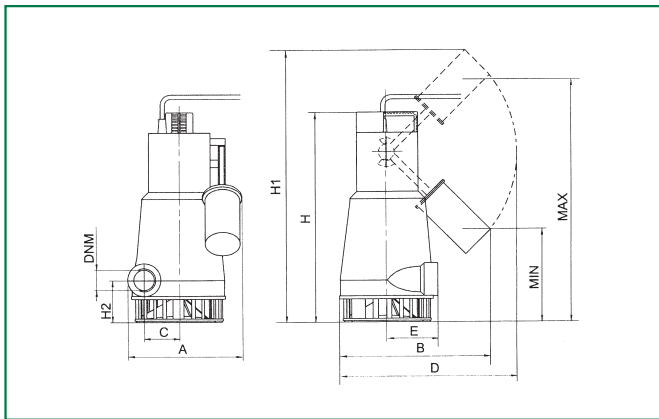

FEKA 600

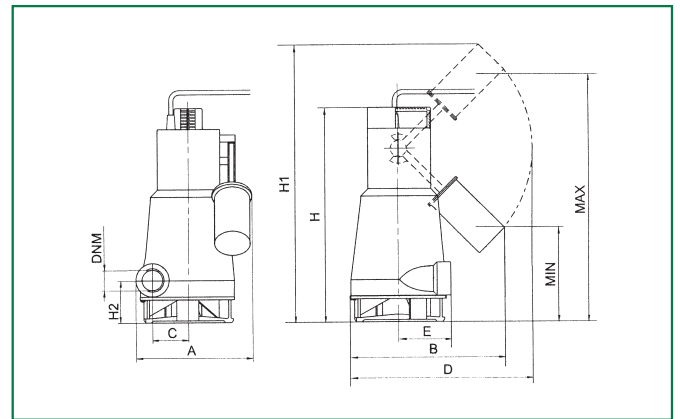

MODEL	A	B	C	D	E	H	H1	H2	LIV. MIN.	LIV. MAX.	DNM	WEIGHT Kg
NOVA 180 M-A	181	235	46	296	82	253	345	38	77	277	1 1/4" G	4,6
NOVA 180 M-NA	148	148	46	-	82	253	-	38	-	-	1 1/4" G	4,5
NOVA 200 M-NA	148	148	46	-	82	253	-	38	-	-	1 1/4" G	4,5
NOVA 300 M-A	181	235	46	296	82	262	354	47	85	285	1 1/4" G	4,6
NOVA 600 M-A	193	235	56	296	90	368	443	73	190	390	1 1/4" G	7
NOVA 600 (M-T)-NA	162	167	56	-	90	368	-	73	-	-	1 1/4" G	6,7
FEKA 600 M-A	193	235	56	296	90	368	443	73	190	390	1 1/4" G	7
FEKA 600 (M-T)-NA	162	167	56	-	90	368	-	73	-	-	1 1/4" G	6,7