

BS 2660 MT 3~ 226

Portable pumps ideal for applications in which the water or liquid contains concentrations of abrasives.



Technical specification



Curves according to: Water, pure ,4 °C,999.9 kg/m³,1.5692 mm²/s

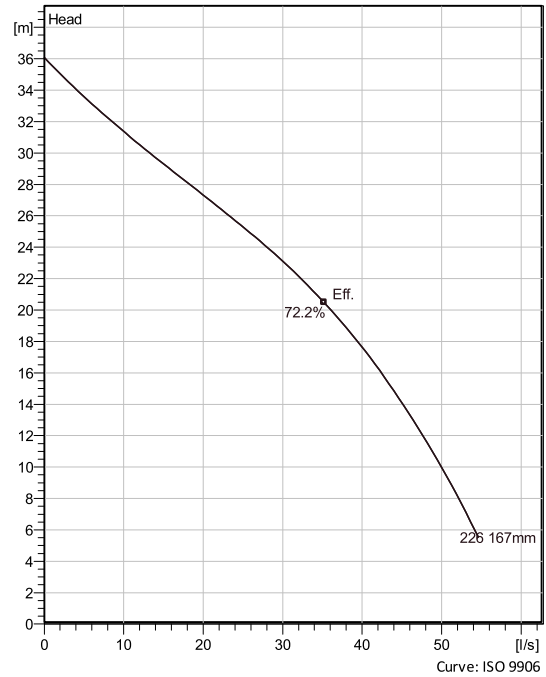

Configuration

Motor number B2660.181 18-15-2BB-W 10KW	Installation type S - Portable Semi permanent, Wet
Impeller diameter 167 mm	Discharge diameter 150 m

Pump information

Impeller diameter 167 mm
Discharge diameter 150 m
Inlet diameter 104 mm
Maximum operating speed 2865 rpm
Number of blades 2

Max. fluid temperature
40 °C

Materials

Impeller Hard-Iron
Stator housing material Aluminium

Project
Block

Created by Joshua Harvey
Created on 2/11/2021 **Last update** 2/11/2021

BS 2660 MT 3~ 226

Technical specification



Motor - General

Motor number B2660.181 18-15-2BB-W 10KW	Phases 3~	Rated speed 2865 rpm	Rated power 10 kW
ATEX approved No	Number of poles 2	Rated current 19 A	Stator variant 16
Frequency 50 Hz	Rated voltage 400 V	Insulation class H	Type of Duty S1
Version code 181			

Motor - Technical

Power factor - 1/1 Load 0.88	Motor efficiency - 1/1 Load 85.7 %	Total moment of inertia 0.0232 kg m ²	Starts per hour max. 30
Power factor - 3/4 Load 0.84	Motor efficiency - 3/4 Load 87.6 %	Starting current, direct starting 115 A	
Power factor - 1/2 Load 0.74	Motor efficiency - 1/2 Load 88.1 %	Starting current, star-delta 38.3 A	

Project
Block

Created by Joshua Harvey
Created on 2/11/2021 **Last update** 2/11/2021

BS 2660 MT 3~ 226

Performance curve



Duty point

Flow

Head

Curves according to: Water, pure 4 °C, 999.9 kg/m³, 1.5692 mm²/s

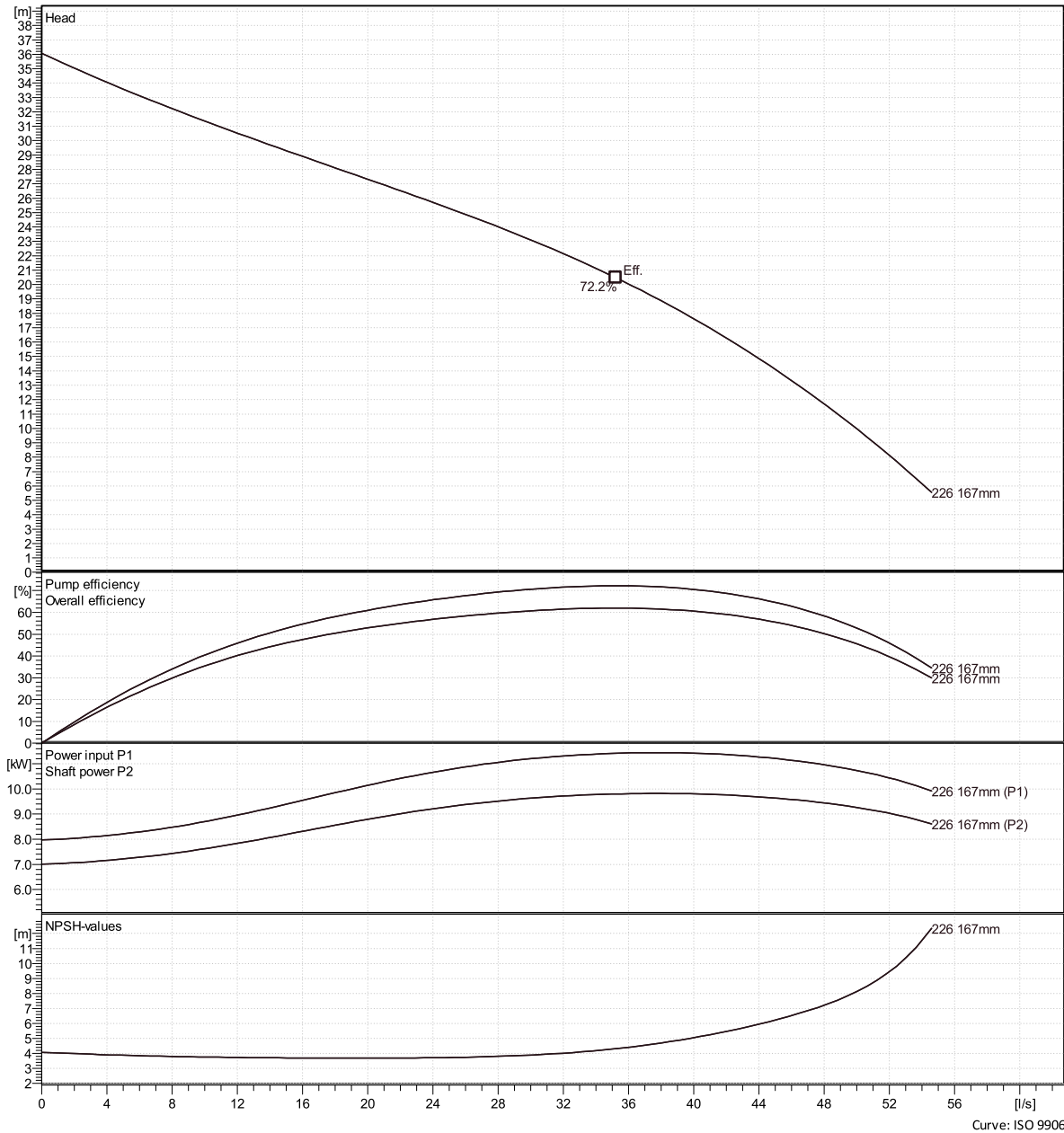

Curve: ISO 9906

Project

Created by Joshua Harvey

Block

Created on 2/11/2021 Last update 2/11/2021

BS 2660 MT 3~ 226

Duty Analysis



Curves according to: Water, pure, 4 °C, 999.9 kg/m³, 1.5692 mm²/s

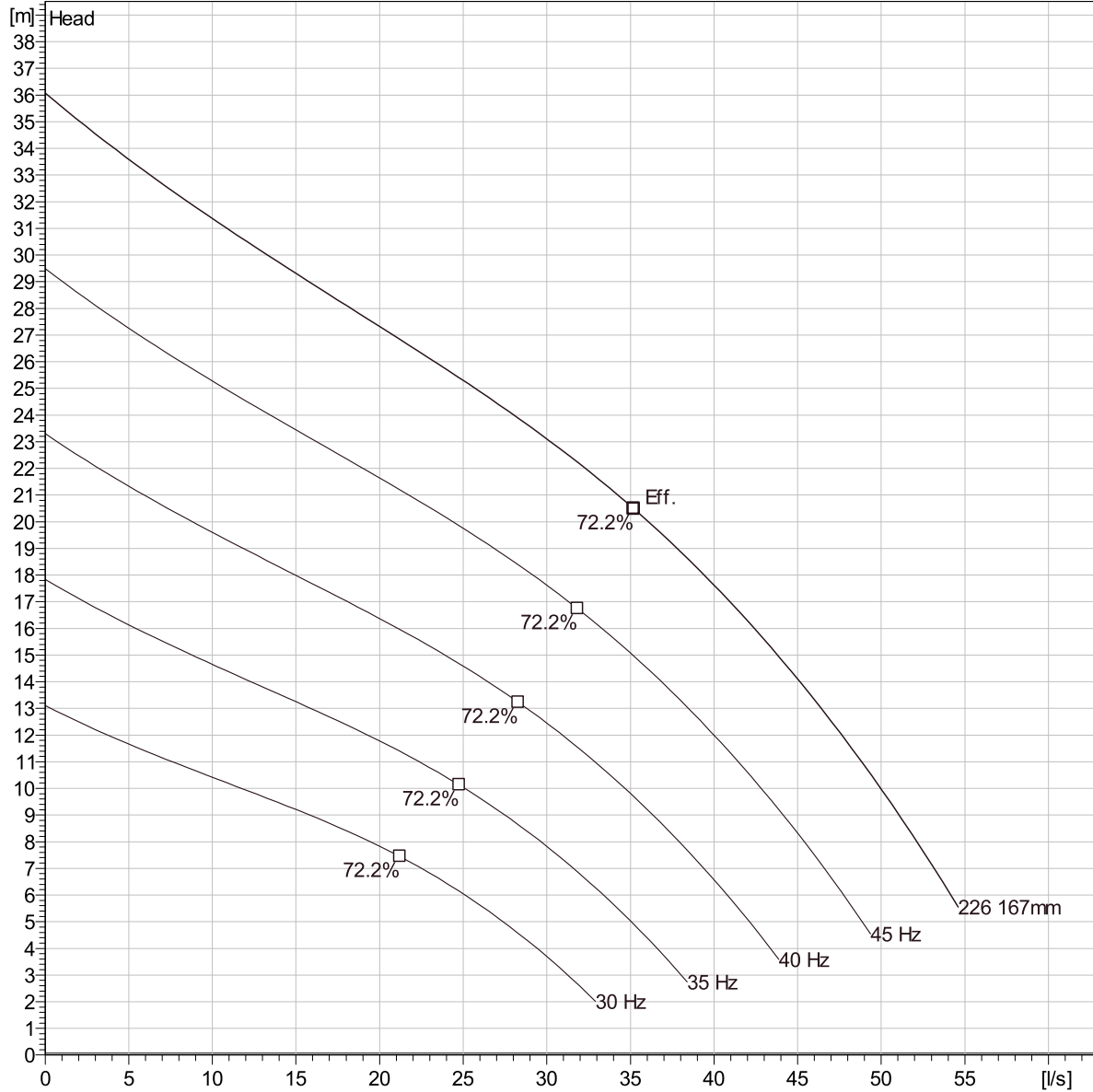

Operating characteristics

Pumps / Systems	Flow	Head	Shaft power	Flow	Head	Shaft power	Hydr.eff.	Specific Energy	NPSHre
-----------------	------	------	-------------	------	------	-------------	-----------	-----------------	--------

Project	Created by	Joshua Harvey
Block	Created on	2/11/2021
	Last update	2/11/2021

BS 2660 MT 3~ 226

VFD Curve



Curves according to: Water, pure, 4 °C, 999.9 kg/m³, 1.5692 mm²/s

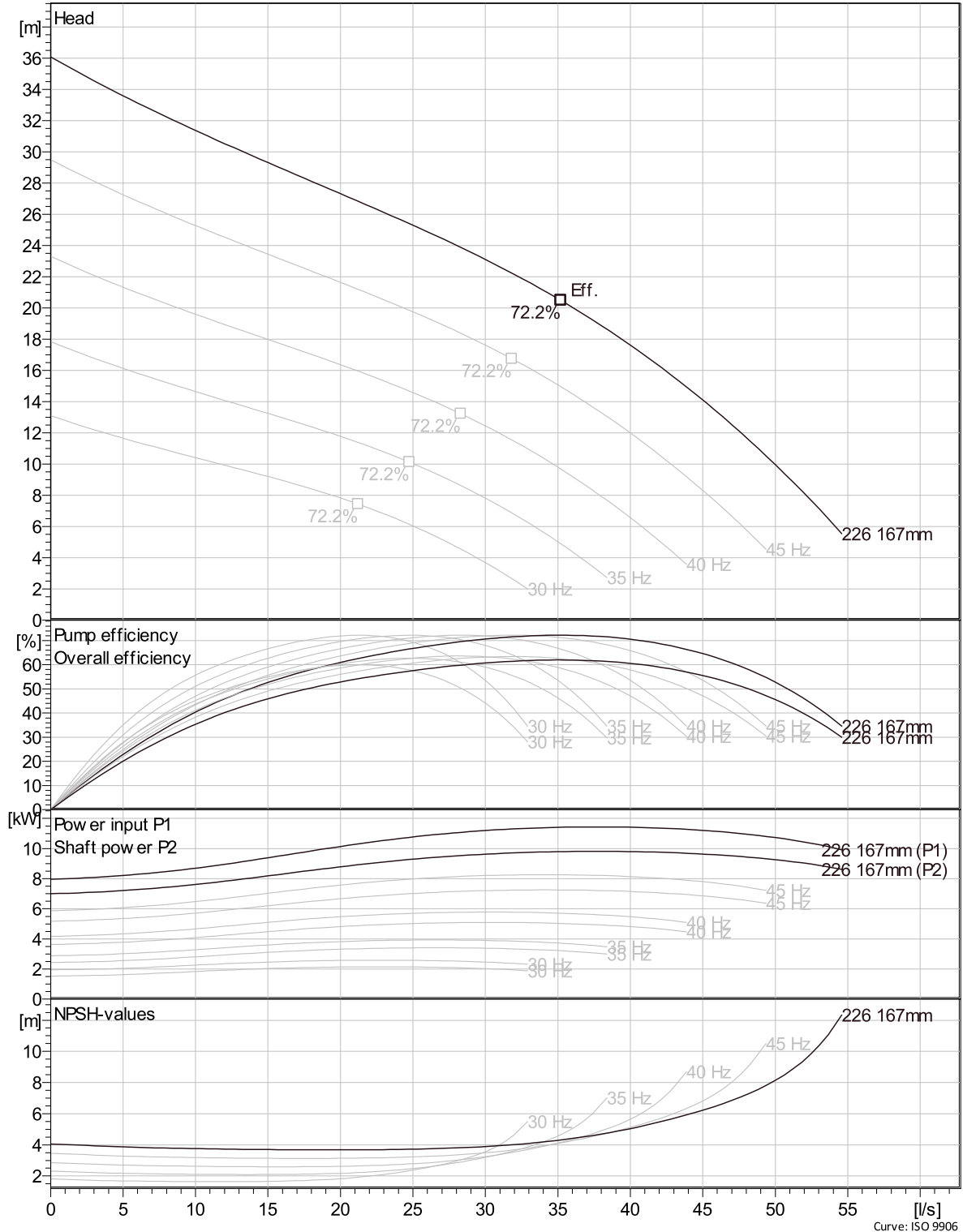

Curve: ISO 9906

Project
Block

Created by Joshua Harvey
Created on 2/11/2021 Last update 2/11/2021

BS 2660 MT 3~ 226

VFD Analysis

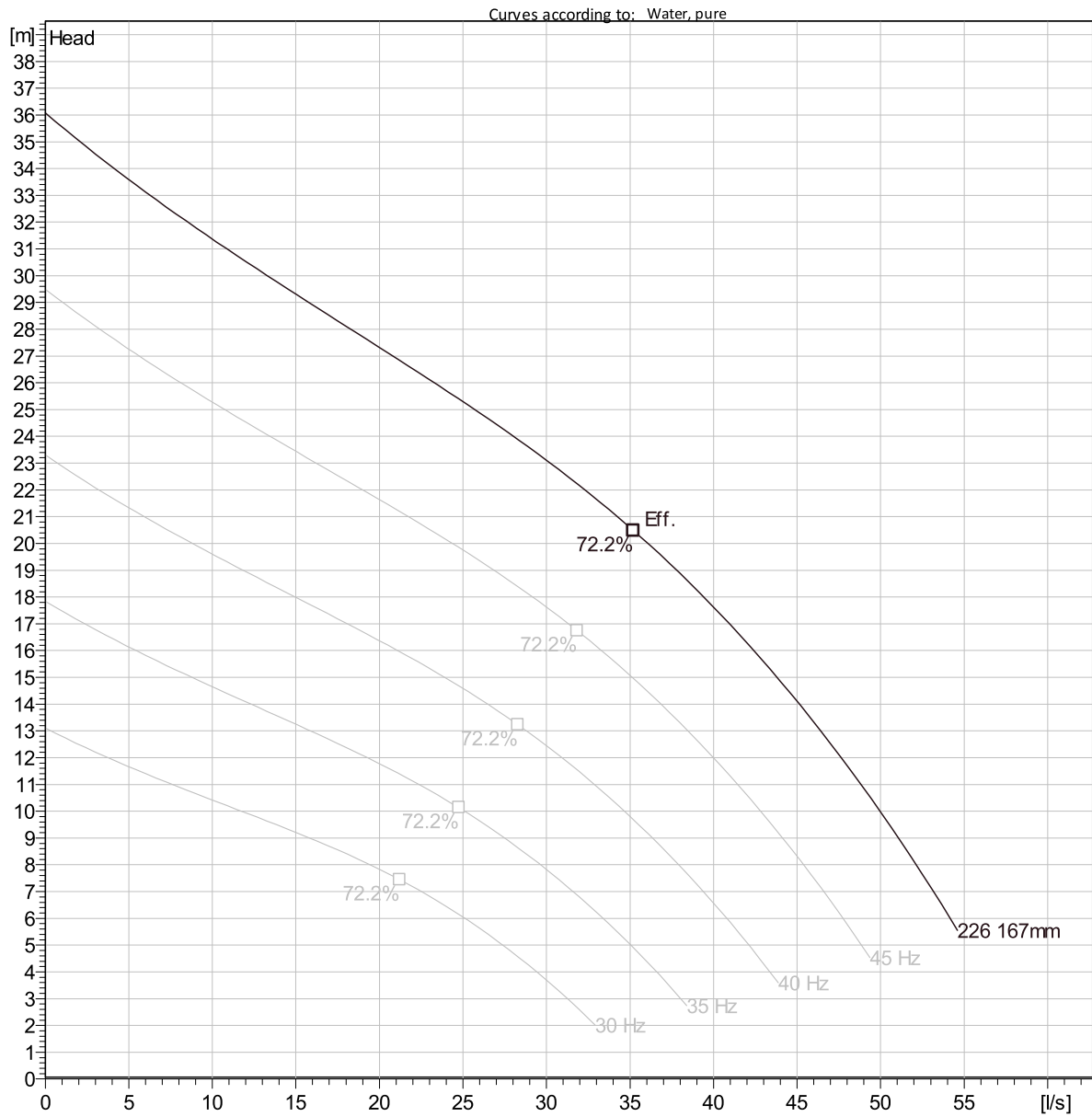

Operating characteristics

Pumps / Systems	Frequency	Flow	Head	Shaft power	Flow	Head	Shaft power	Hydr.eff.	Specific Energy	NPSHre
-----------------	-----------	------	------	-------------	------	------	-------------	-----------	-----------------	--------

Project	Created by	Joshua Harvey
Block	Created on	2/11/2021
	Last update	2/11/2021

BS 2660 MT 3~ 226

Dimensional drawing

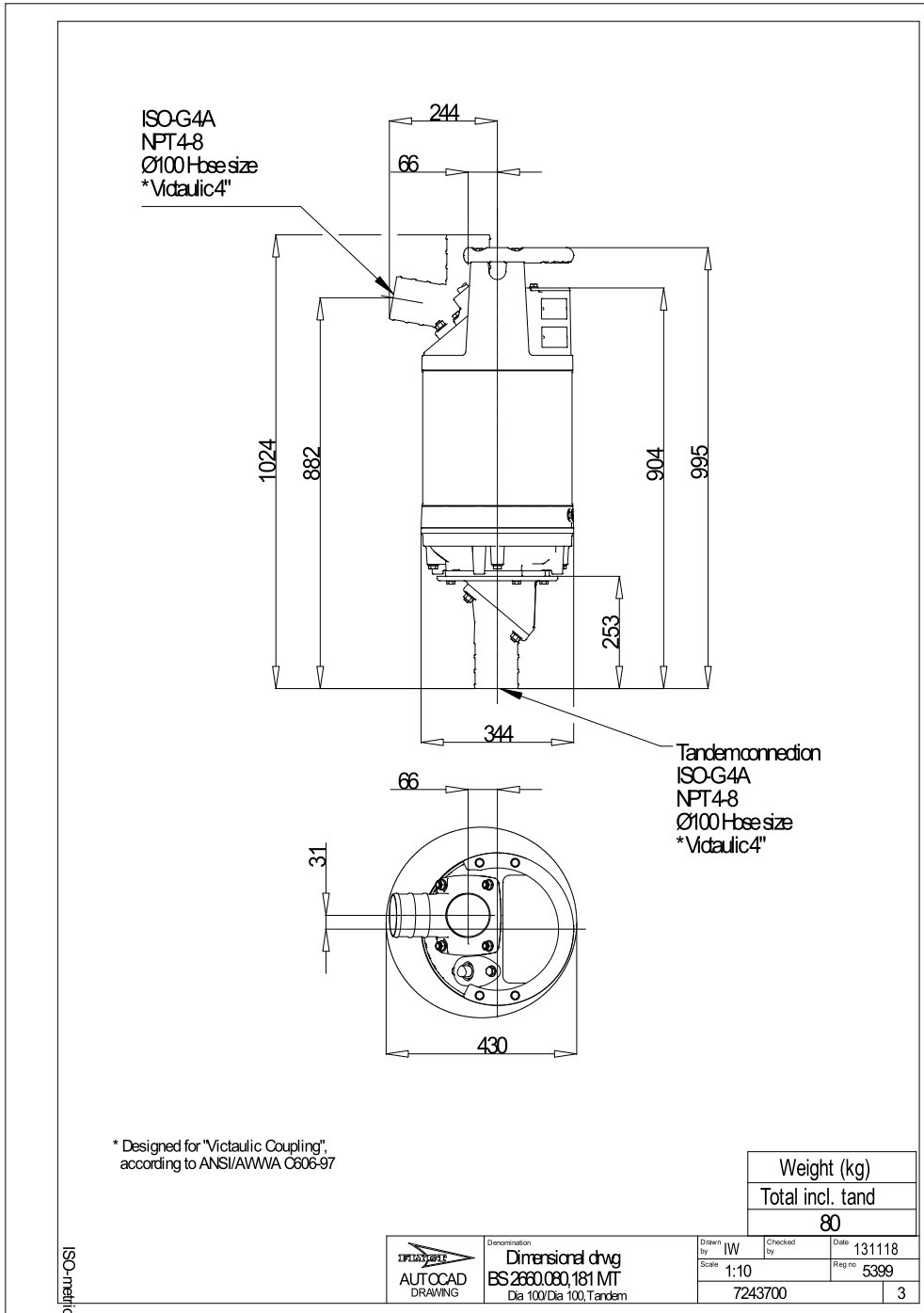

Project Created by Joshua Harvey
 Block Created on 2/11/2021 Last update 2/11/2021