

BS 2640 HT 3~ 251

Portable pumps ideal for applications in which the water or liquid contains concentrations of abrasives.



Technical specification



Curves according to: Water, pure ,4 °C,999.9 kg/m³,1.5692 mm²/s

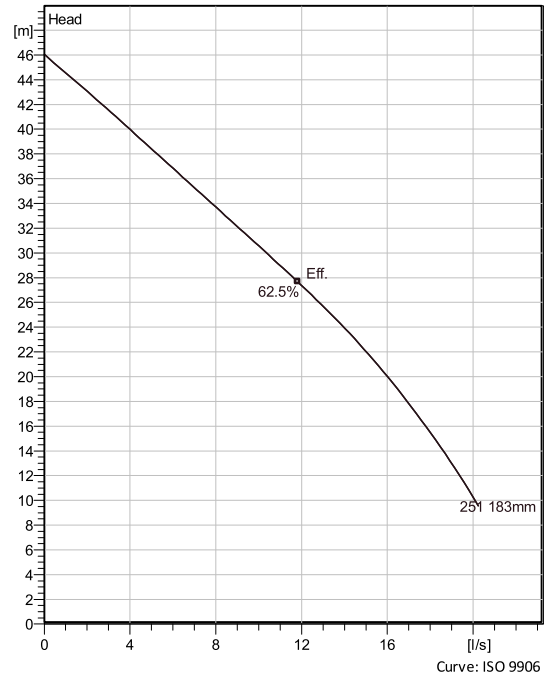

Configuration

Motor number B2640.181 15-14-2BB-W 5.6KW	Installation type S - Portable Semi permanent, Wet
Impeller diameter 183 mm	Discharge diameter 75 m

Pump information

Impeller diameter 183 mm
Discharge diameter 75 m
Inlet diameter 72 mm
Maximum operating speed 2895 rpm
Number of blades 2
Max. fluid temperature 40 °C

Materials

Impeller Hard-Iron
Stator housing material Aluminium

Project
Block

Created by Joshua Harvey
Created on 2/11/2021 Last update 2/11/2021

BS 2640 HT 3~ 251

Technical specification



Motor - General

Motor number B2640.181 15-14-2BB-W 5.6KW	Phases 3~	Rated speed 2895 rpm	Rated power 5.6 kW
ATEX approved No	Number of poles 2	Rated current 11 A	Stator variant 1
Frequency 50 Hz	Rated voltage 400 V	Insulation class H	Type of Duty S1
Version code 181			

Motor - Technical

Power factor - 1/1 Load 0.87	Motor efficiency - 1/1 Load 84.2 %	Total moment of inertia 0.0217 kg m ²	Starts per hour max. 30
Power factor - 3/4 Load 0.81	Motor efficiency - 3/4 Load 85.1 %	Starting current, direct starting 78 A	
Power factor - 1/2 Load 0.69	Motor efficiency - 1/2 Load 84.1 %	Starting current, star-delta 26 A	

Project
Block

Created by Joshua Harvey
Created on 2/11/2021 **Last update** 2/11/2021

BS 2640 HT 3~ 251

Performance curve



Duty point

Flow

Head

Curves according to: Water, pure 4 °C, 999.9 kg/m³, 1.5692 mm²/s

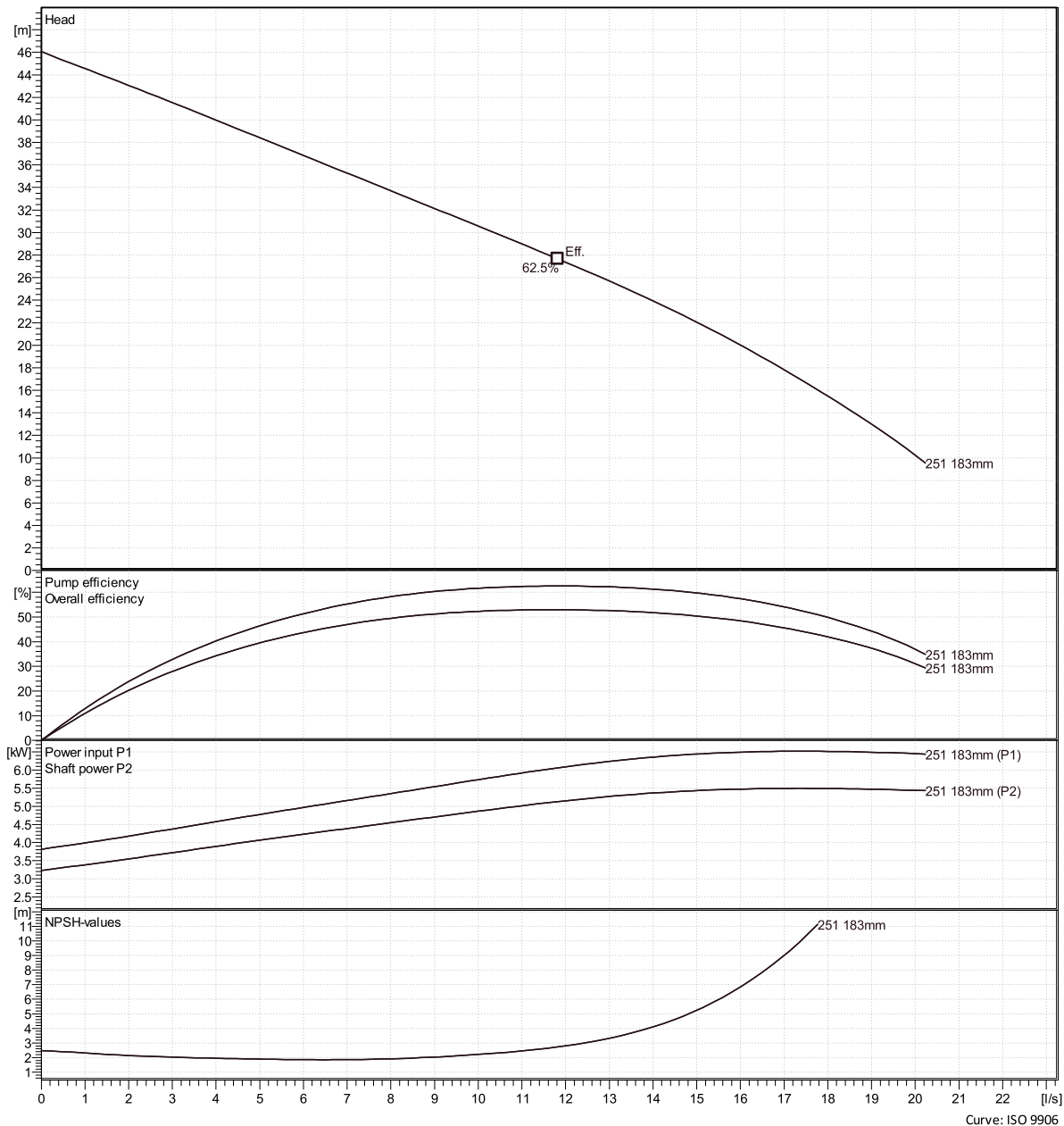

Project
Block

Created by Joshua Harvey
Created on 2/11/2021 Last update 2/11/2021

Curve: ISO 9906

BS 2640 HT 3~ 251

Duty Analysis



Curves according to: Water, pure, 4 °C, 999.9 kg/m³, 1.5692 mm²/s

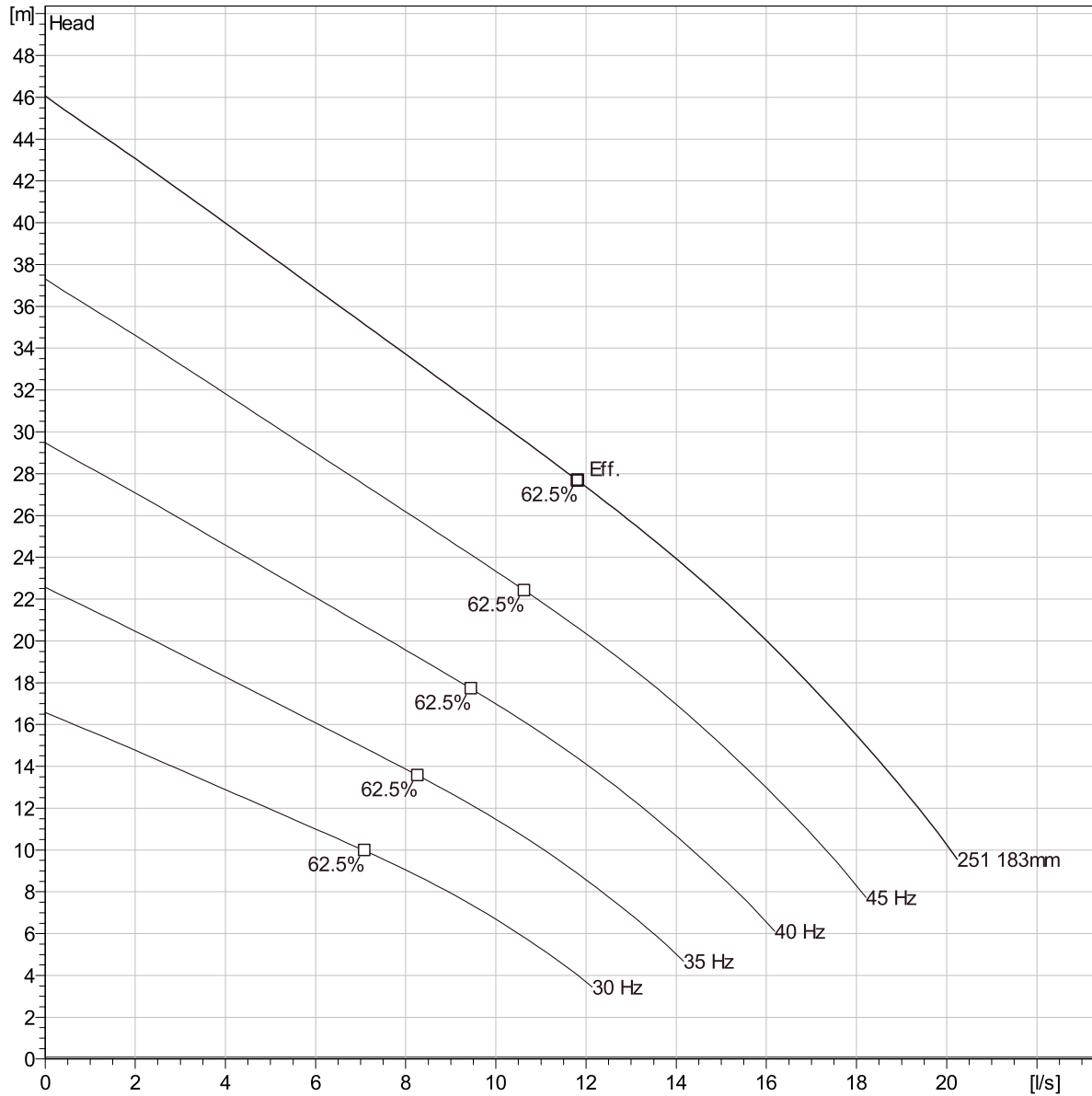

Operating characteristics

Pumps / Systems	Flow	Head	Shaft power	Flow	Head	Shaft power	Hydr.eff.	Specific Energy	NPSHre
-----------------	------	------	-------------	------	------	-------------	-----------	-----------------	--------

Project	Created by	Joshua Harvey
Block	Created on	2/11/2021
	Last update	2/11/2021

BS 2640 HT 3~ 251

VFD Curve



Curves according to: Water, pure, 4 °C, 999.9 kg/m³, 1.5692 mm²/s

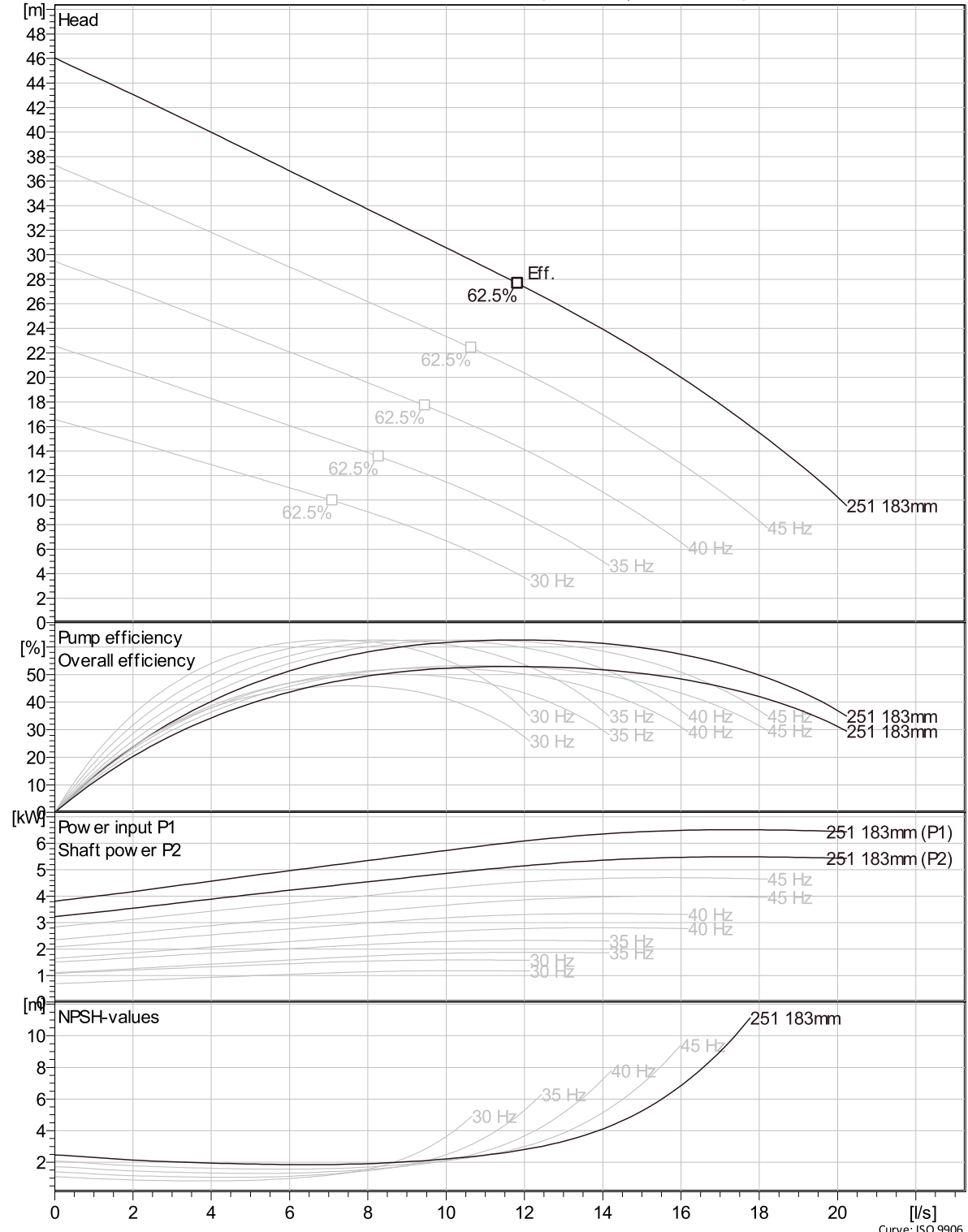

Curve: ISO 9906

Project	Created by	Joshua Harvey
Block	Created on	2/11/2021
	Last update	2/11/2021

BS 2640 HT 3~ 251

VFD Analysis

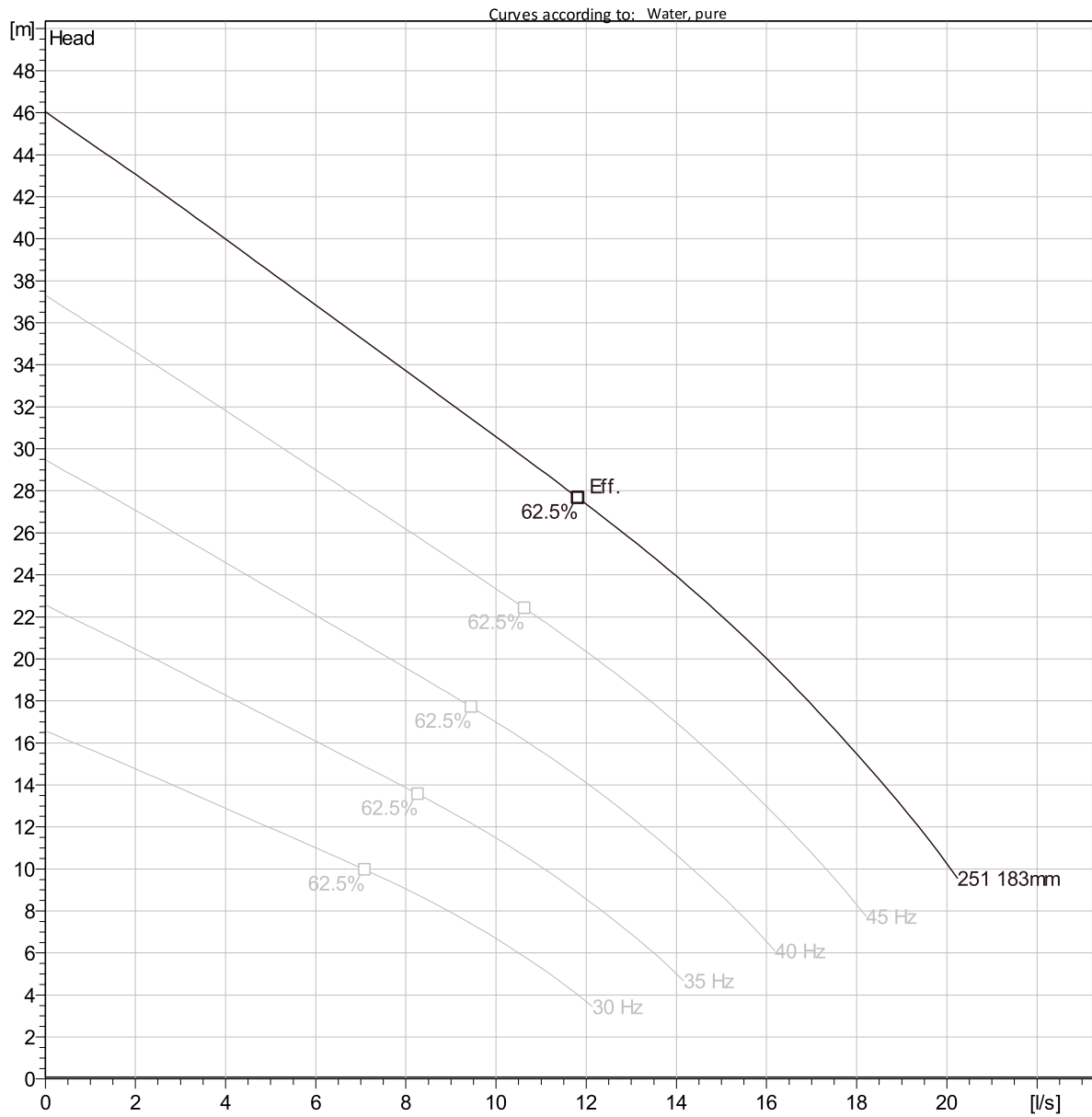

Operating characteristics

Pumps / Systems	Frequency	Flow	Head	Shaft power	Flow	Head	Shaft power	Hydr.eff.	Specific Energy	NPSHre
-----------------	-----------	------	------	-------------	------	------	-------------	-----------	-----------------	--------

Project	Created by	Joshua Harvey
Block	Created on	2/11/2021
	Last update	2/11/2021

BS 2640 HT 3~ 251

Dimensional drawing

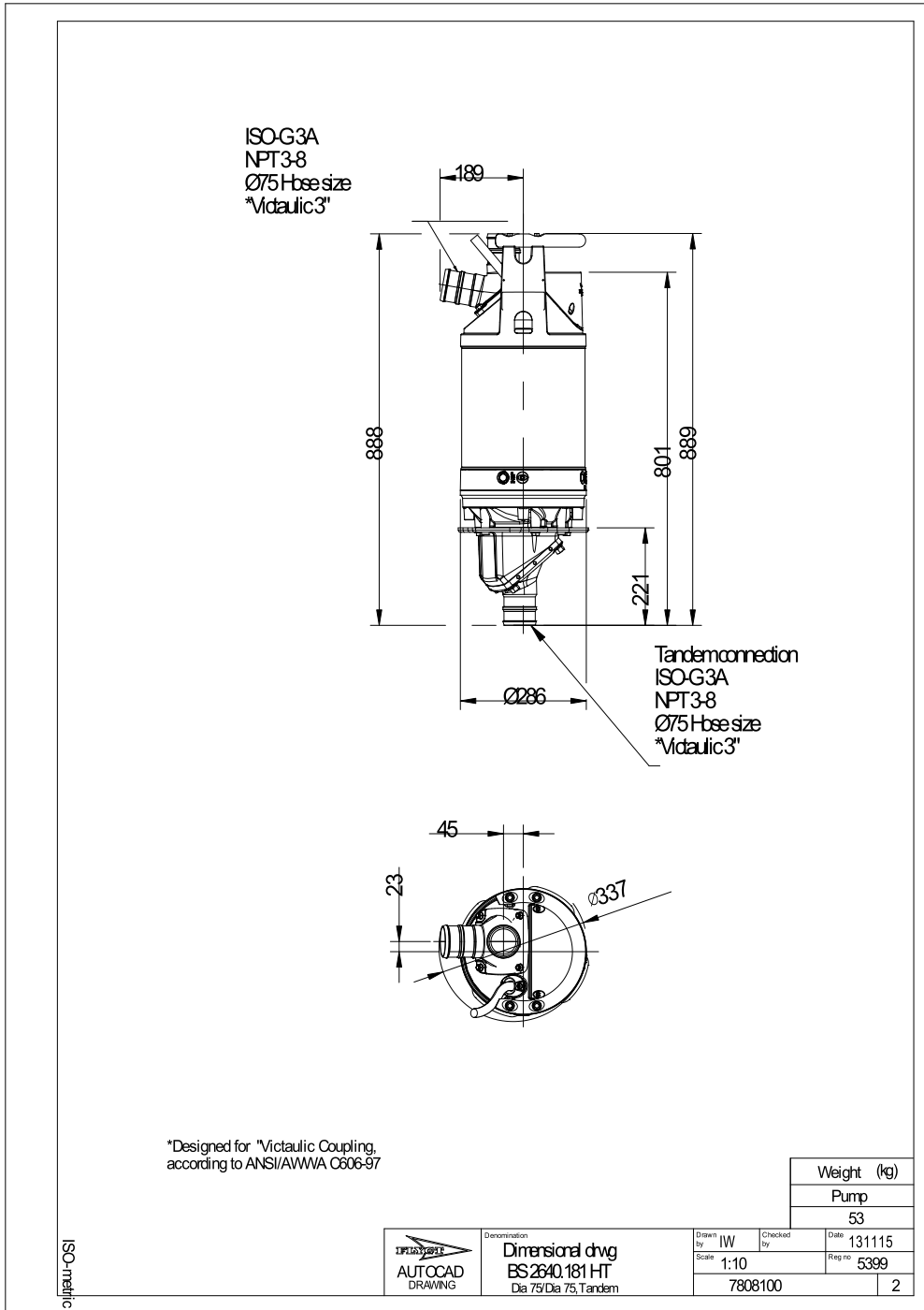

Project	Created by	Joshua Harvey
Block	Created on	2/11/2021 Last update 2/11/2021