

Count	Description
1	<p data-bbox="225 338 568 367"><b>TPE3 100-150-S A-F-A-BQQE</b></p>  <p data-bbox="225 660 488 689">Product No.: <a href="#">99272201</a></p> <p data-bbox="225 719 1406 797">Single-stage, close-coupled, volute pump with in-line suction and discharge ports of identical diameter. The pump is of the top-pull-out design, i.e. the power head (motor, pump head and impeller) can be removed for maintenance or service while the pump housing remains in the pipework.</p> <p data-bbox="225 804 1418 857">The shaft seal is according to EN 12756. Pipework connection is via PN 10 DIN flanges (EN 1092-2 and ISO 7005-2).</p> <p data-bbox="225 864 1433 916">The pump is fitted with a fan-cooled, permanent-magnet synchronous motor. The motor efficiency is classified as IE5 in accordance with IEC 60034-30-2.</p> <p data-bbox="225 922 1453 974">The motor includes a frequency converter and PI controller in the motor terminal box. This enables continuously variable control of the motor speed, which again enables adaptation of the performance to a given requirement.</p> <p data-bbox="225 1005 1118 1034">The pump is fitted with a combined temperature- and differential-pressure sensor.</p> <p data-bbox="225 1095 336 1124"><b>Controls:</b></p> <p data-bbox="225 1126 667 1155">Frequency converter: Built-in</p> <p data-bbox="225 1184 309 1214"><b>Liquid:</b></p> <p data-bbox="225 1216 657 1245">Pumped liquid: Water</p> <p data-bbox="225 1247 727 1276">Liquid temperature range: -13 .. 248 °F</p> <p data-bbox="225 1279 707 1308">Liquid temperature during operation: 68 °F</p> <p data-bbox="225 1310 708 1339">Density: 62.29 lb/ft<sup>3</sup></p> <p data-bbox="225 1368 349 1397"><b>Technical:</b></p> <p data-bbox="225 1400 826 1429">Pump speed on which pump data is based: 3410 rpm</p> <p data-bbox="225 1431 727 1460">Rated flow: 195 US gpm</p> <p data-bbox="225 1462 675 1491">Rated head: 32.15 ft</p> <p data-bbox="225 1494 663 1523">Actual impeller diameter: 3.54 in</p> <p data-bbox="225 1525 660 1554">Primary shaft seal: BQQE</p> <p data-bbox="225 1556 786 1585">Curve tolerance: ISO9906:2012 3B</p> <p data-bbox="225 1615 341 1644"><b>Materials:</b></p> <p data-bbox="225 1646 903 1749">Pump housing: Cast iron EN-JL1040 ASTM A48-40 B</p> <p data-bbox="225 1751 903 1780">Impeller: Composite PES/PP 30% GF</p> <p data-bbox="225 1809 365 1839"><b>Installation:</b></p> <p data-bbox="225 1841 711 1870">Range of ambient temperature: -4 .. 122 °F</p> <p data-bbox="225 1872 671 1901">Maximum operating pressure: 145 psi</p> <p data-bbox="225 1904 632 1933">Flange standard: DIN</p> <p data-bbox="225 1935 675 1964">Pipe connection: DN 100</p> <p data-bbox="225 1966 660 1995">Pressure stage: PN 10</p> <p data-bbox="225 1998 687 2027">Port-to-port length: 17 3/4 in</p> <p data-bbox="225 2029 635 2058">Flange size for motor: 56C</p> <p data-bbox="225 2087 400 2116"><b>Electrical data:</b></p> <p data-bbox="225 2119 651 2148">Motor type: 90SC</p>



Company name:

Created by:

Phone:

Date:

1/10/2019

Count	Description
	IE Efficiency class: IE5
	Rated power - P2: 2 HP
	Main frequency: 60 Hz
	Rated voltage: 1 x 200-240 V
	Rated current: 9.10-7.60 A
	Cos phi - power factor: 0.99
	Rated speed: 360-4000 rpm
	IE efficiency: 87.4%
	Motor efficiency at full load: 87.4 %
	Enclosure class (IEC 34-5): IP55
	Insulation class (IEC 85): F
	<b>Others:</b>
	Minimum efficiency index, MEI : 0.7
	ErP status: EuP Standalone/Prod.
	Net weight: 86.9 lb
	Gross weight: 106 lb
	Shipping volume: 5660 ft <sup>3</sup>
	Danish VVS No.: 381605150
	Country of origin: HU
	Custom tariff no.: 84137051

## 99272201 TPE3 100-150-S A-F-A-BQQE 60 Hz

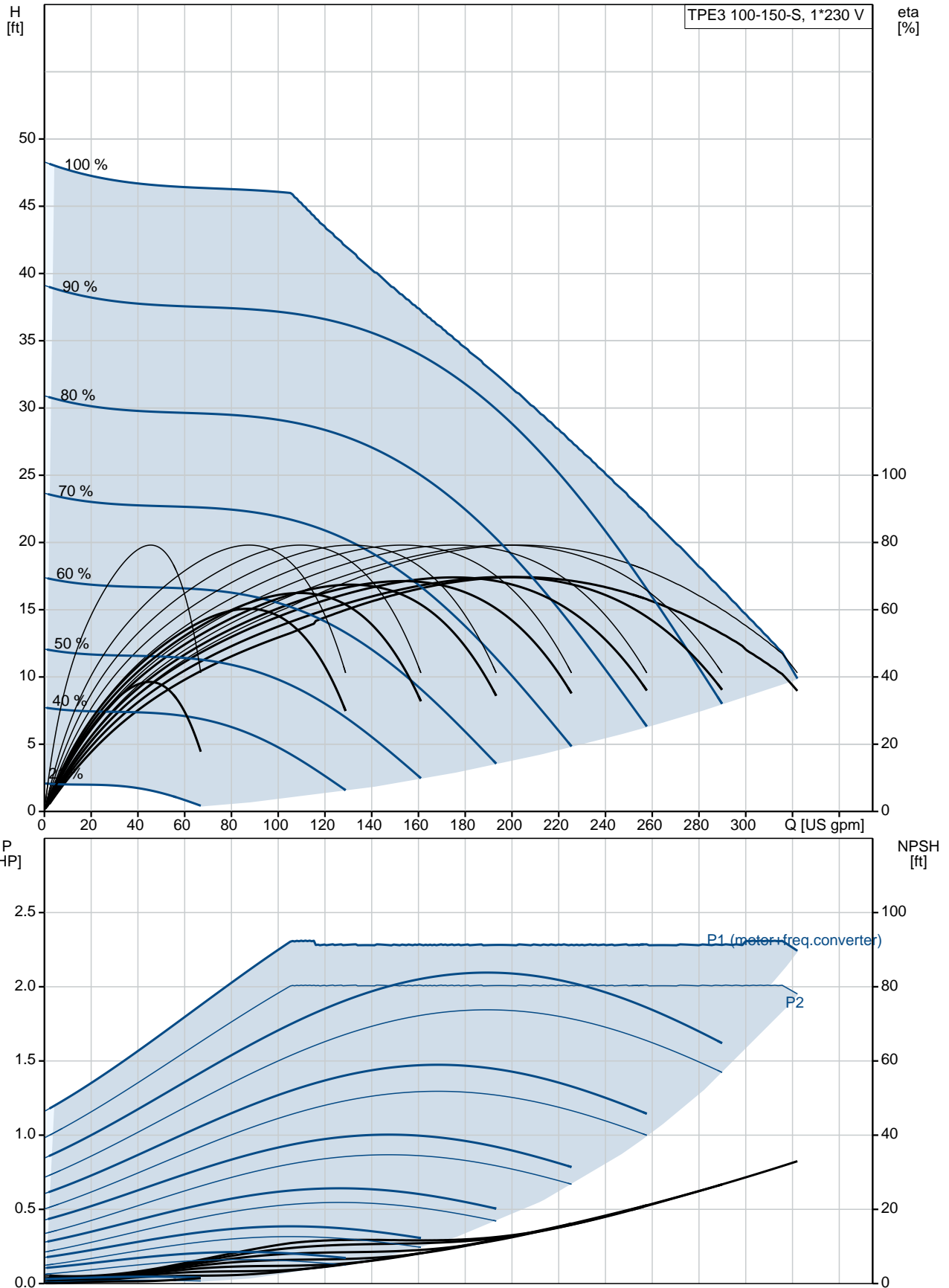

Description	Value
<b>General information:</b>	
Product name:	TPE3 100-150-S A-F-A-BQQE
Product No.:	99272201
EAN:	5713826359935
<b>Technical:</b>	
Pump speed on which pump data is based:	3410 rpm
Rated flow:	195 US gpm
Rated head:	32.15 ft
Head max:	49.22 ft
Actual impeller diameter:	3.54 in
Primary shaft seal:	BQQE
Curve tolerance:	ISO9906:2012 3B
Pump version:	A
Model:	A
<b>Materials:</b>	
Pump housing:	Cast iron
	EN-JL1040
	ASTM A48-40 B
Impeller:	Composite PES/PP 30% GF
Material code:	A
<b>Installation:</b>	
Range of ambient temperature:	-4 .. 122 °F
Maximum operating pressure:	145 psi
Flange standard:	DIN
Pipe connection:	DN 100
Pressure stage:	PN 10
Port-to-port length:	17 3/4 in
Flange size for motor:	56C
Connect code:	F
<b>Liquid:</b>	
Pumped liquid:	Water
Liquid temperature range:	-13 .. 248 °F
Liquid temperature during operation:	68 °F
Density:	62.29 lb/ft <sup>3</sup>
<b>Electrical data:</b>	
Motor type:	90SC
IE Efficiency class:	IE5
Rated power - P2:	2 HP
Main frequency:	60 Hz
Rated voltage:	1 x 200-240 V
Rated current:	9.10-7.60 A
Cos phi - power factor:	0.99
Rated speed:	360-4000 rpm
IE efficiency:	87.4%
Motor efficiency at full load:	87.4 %
Enclosure class (IEC 34-5):	IP55
Insulation class (IEC 85):	F
Motor protection:	YES
Motor Number:	99137988
<b>Controls:</b>	
Control panel:	HMI300 - Graphical
Function Module:	FM300 - Advanced
Frequency converter:	Built-in
<b>Others:</b>	
Minimum efficiency index, MEI :	0.7
ErP status:	EuP Standalone/Prod.
Net weight:	86.9 lb

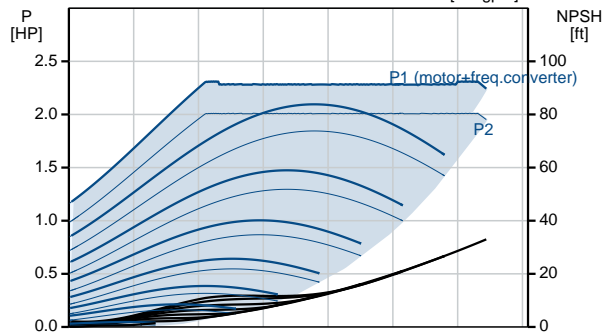
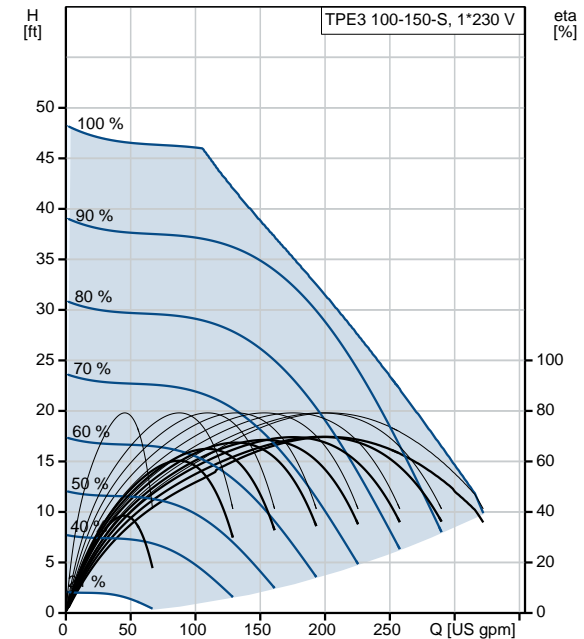



**Company name:**

**Created by:**

**Phone:**

**Date:**

1/10/2019

Description	Value
Gross weight:	106 lb
Shipping volume:	5660 ft <sup>3</sup>
Config. file no:	98481412
Danish VVS No.:	381605150
Country of origin:	HU
Custom tariff no.:	84137051

## 99272201 TPE3 100-150-S A-F-A-BQQE 60 Hz

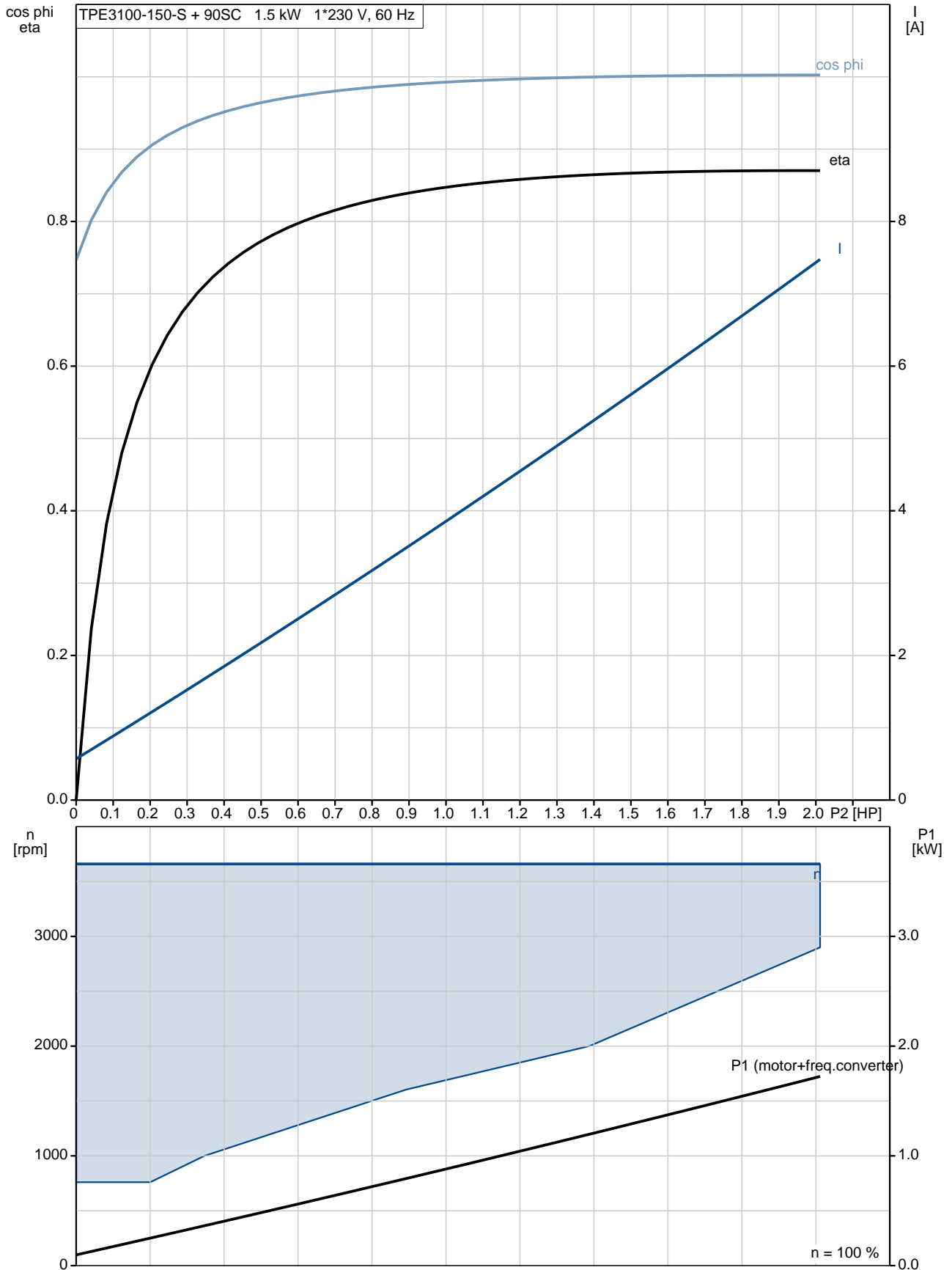

**99272201 TPE3 100-150-S A-F-A-BQQE 60 Hz**

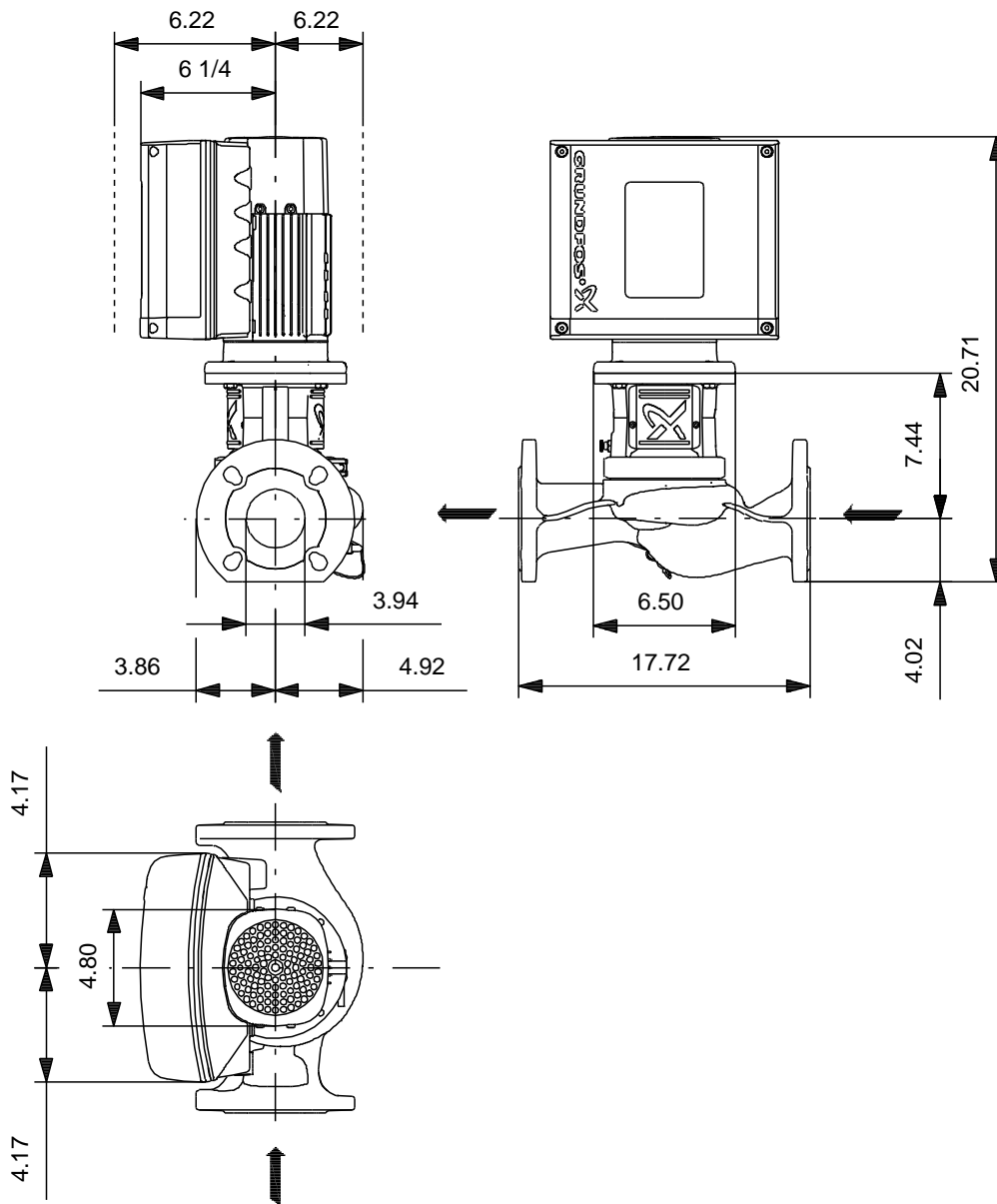

Note! All units are in [mm] unless otherwise stated.  
Disclaimer: This simplified dimensional drawing does not show all details.

## 99272201 TPE3 100-150-S A-F-A-BQQE 60 Hz

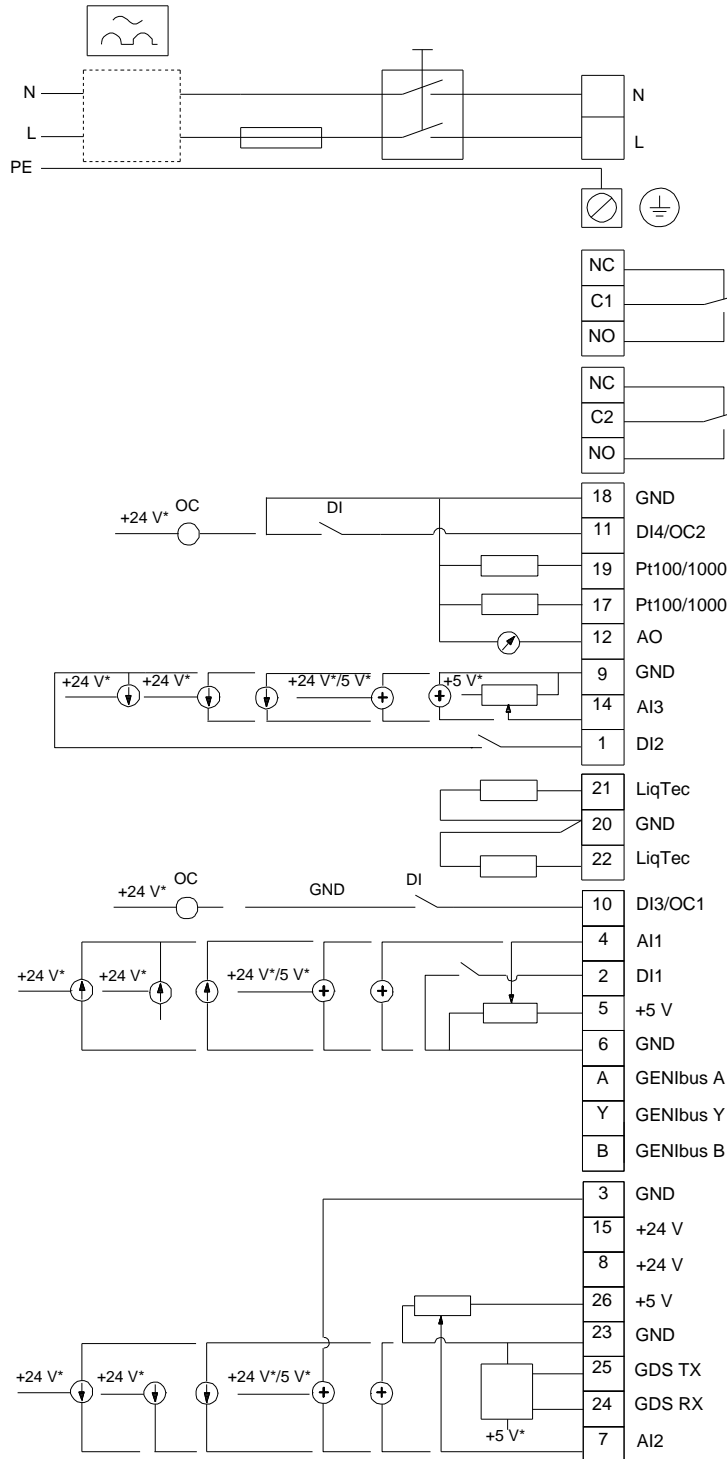

All units are [mm] unless otherwise presented.