

Qty.	Description
1	<p data-bbox="87 226 391 248"><b>CRE 95-2-1 N-F-A-E-HQQE</b></p> <div data-bbox="199 280 319 560" style="text-align: center;">  </div> <p data-bbox="478 571 949 593" style="text-align: center;"><b>Note! Product picture may differ from actual product</b></p> <p data-bbox="87 604 351 627">Product No.: <a href="#">99264418</a></p> <p data-bbox="87 660 1532 739">Vertical, multistage centrifugal pump with inlet and outlet ports on same the level (inline). The pump head and base are in cast iron – all other wetted parts are in stainless steel. The Grundfos cartridge shaft seal ensures high reliability, safe handling, and easy access and service. Power transmission is via a rigid split coupling. Pipe connection is via DIN flanges.</p> <p data-bbox="87 772 798 795">The pump is fitted with a 3-phase, fan-cooled asynchronous motor.</p> <p data-bbox="87 806 1516 862">The motor includes a frequency converter and PI controller in the motor terminal box. This enables continuously variable control of the motor speed, which again enables adaptation of the performance to a given requirement.</p> <p data-bbox="87 873 1548 918">An operating panel on the motor terminal box enables setting of required setpoint as well as setting of pump to "Min." or "Max." operation or to "Stop". The operating panel has indicator lights for "Operation" and "Fault".</p> <p data-bbox="87 929 1548 974">Communication with the pump is possible by means of Grundfos GO Remote (accessory). The remote control enables further settings as well as reading out of a number of parameters such as "Actual value", "Speed", "Power input" and total "Power consumption".</p> <p data-bbox="87 985 678 1008">The terminal box holds terminals for these connections:</p> <ul data-bbox="119 1019 1412 1332" style="list-style-type: none"> <li>• pump start/stop input (potential-free contact)</li> <li>• remote setpoint setting via analog signal, 0-10 V, 0(4)-20 mA</li> <li>• 10 V voltage supply for setpoint potentiometer, I<sub>max</sub> = 5 mA</li> <li>• three analog sensor inputs, 0-10 V, 0(4)-20 mA; the factory-fitted pressure sensor is connected to one of these inputs</li> <li>• 24 V voltage supply for sensor, I<sub>max</sub> = 40 mA</li> <li>• one analog output</li> <li>• three digital inputs</li> <li>• two Pt100 inputs</li> <li>• two potential-free fault signal relays with changeover contact, reporting "Fault", "Operation" or "Ready"</li> <li>• RS-485 GENIbus connection</li> <li>• interface for Grundfos CIM fieldbus module.</li> </ul> <p data-bbox="87 1366 399 1400"><b>Further product details</b></p> <p data-bbox="87 1411 1564 1456">The pump is equipped with a pressure sensor registering pump outlet pressure and enabling controlled pump operation based on constant pressure.</p> <p data-bbox="87 1467 1548 1512">An operating panel on the motor terminal box enables setting of required setpoint as well as setting of pump to "Min." or "Max." operation or to "Stop". The operating panel has indicator lights for "Operation" and "Fault".</p> <p data-bbox="87 1523 1548 1568">Communication with the pump is possible by means of Grundfos GO Remote (accessory). The remote control enables further settings as well as reading out of a number of parameters such as "Actual value", "Speed", "Power input" and total "Power consumption".</p> <p data-bbox="87 1579 1452 1601">Steel, cast iron and aluminium components have an epoxy-based coating made in a cathodic electro-deposition (CED) process.</p> <p data-bbox="87 1612 1516 1657">CED is a high-quality dip-painting process where an electrical field around the products ensures deposition of paint particles as a thin, well-controlled layer on the surface.</p> <p data-bbox="87 1668 606 1691">An integral part of the process is a pretreatment.</p> <p data-bbox="87 1702 582 1724">The entire process consists of these elements:</p> <ol data-bbox="119 1736 582 1848" style="list-style-type: none"> <li>1) Alkaline-based cleaning.</li> <li>2) Zinc phosphating.</li> <li>3) Cathodic electro-deposition.</li> <li>4) Curing to a dry film thickness 18-22 my m.</li> </ol> <p data-bbox="87 1848 774 1870">The colour code for the finished product is NCS 9000/RAL 9005.</p> <p data-bbox="87 1904 167 1937"><b>Pump</b></p> <p data-bbox="87 1948 1500 1993">A long split coupling connects the pump and motor shaft. It is enclosed in the motor stool by means of two coupling guards. The long coupling makes it possible to replace the shaft seal without removing the motor from the pump.</p>

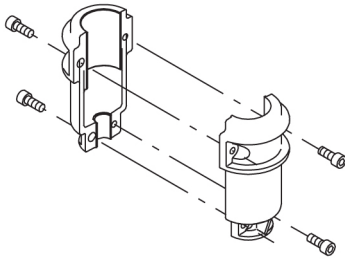

The motor stool connects the pump head and motor. The pump head has a combined 1/2" priming plug and vent screw.

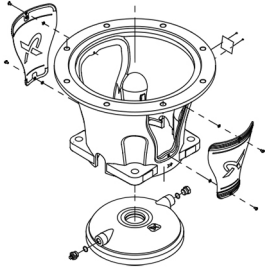

The pump is fitted with a balanced O-ring seal unit with a rigid torque-transmission system.

This seal type is assembled in a cartridge unit which makes replacement safe and easy.

Due to the balancing, this seal type is suitable for high-pressure applications.

The cartridge construction also protects the pump shaft from possible wear from a dynamic O-ring between pump shaft and shaft seal.

Primary seal:

- Rotating seal ring material: silicon carbide (SiC)
- Stationary seat material: silicon carbide (SiC)

This material pairing is used where higher corrosion resistance is required. The high hardness of this material pairing offers good resistance against abrasive particles.

Secondary seal material: EPDM (ethylene-propylene rubber)

EPDM has excellent resistance to hot water. EPDM is not suitable for mineral oils.

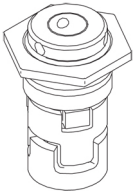

The shaft seal is screwed into the pump head.

The chambers and impellers are made of stainless-steel sheet. The chambers are provided with a PEEK neck ring offering improved sealing and high efficiency. The impellers have smooth surfaces, and the shape of the blades ensure a high efficiency.

The base is made of cast iron and mounted on a separate cast-iron base plate.

Both the inlet and the outlet side of the base have two pressure gauge tapings.

The pump is secured to the foundation by four bolts through the base plate.

The flanges are fastened to the base by means of locking rings.

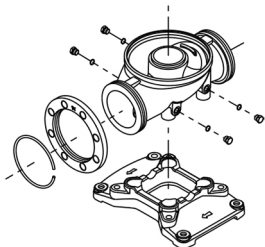

## Motor

The motor is a totally enclosed, fan-cooled motor with principal dimensions to IEC and DIN standards. The motor is flange-mounted with free-hole flange (FF).

Motor-mounting designation in accordance with IEC 60034-7: IM B 5 (Code I) / IM 3001 (Code II).

Electrical tolerances comply with IEC 60034.

The motor efficiency is classified as IE3 in accordance with IEC 60034-30-1.

The motor requires no external motor protection. The motor control unit incorporates protection against slow- and quick-rising temperatures, e.g. constant overload and stalled conditions.

## Technical data

Qty.	Description
	<p>Liquid:</p> <p>Pumped liquid: Water</p> <p>Liquid temperature range: -20 .. 120 °C</p> <p>Selected liquid temperature: 20 °C</p> <p>Density: 998.2 kg/m<sup>3</sup></p> <p>Technical:</p> <p>Pump speed on which pump data are based: 3560 rpm</p> <p>Rated flow: 114 m<sup>3</sup>/h</p> <p>Rated head: 56.7 m</p> <p>Pump orientation: Vertical</p> <p>Shaft seal arrangement: Single</p> <p>Code for shaft seal: HQQE</p> <p>Approvals: CE,EAC,UKCA</p> <p>Approvals for drinking water: ACS,WRAS</p> <p>Curve tolerance: ISO9906:2012 3B</p> <p>Materials:</p> <p>Base: Ductile cast iron EN 1563 EN-GJS-500-7 ASTM A536-84 65-45-12</p> <p>Impeller: Stainless steel EN 1.4301 AISI 304</p> <p>Bearing: WC/WC</p> <p>Support bearing: Graflon</p> <p>Material certified according to: European standards</p> <p>Installation:</p> <p>t max amb: 40 °C</p> <p>Maximum operating pressure: 16 bar</p> <p>Max pressure at stated temp: 16 bar / 120 °C</p> <p>Type of connection: DIN</p> <p>Size of inlet connection: DN 100</p> <p>Size of outlet connection: DN 100</p> <p>Pressure rating for connection: PN 16</p> <p>Flange size for motor: FF300</p> <p>Electrical data:</p> <p>Motor standard: IEC</p> <p>Motor type: 180MB</p> <p>IE Efficiency class: IE3</p> <p>Rated power - P2: 22 kW</p> <p>Power (P2) required by pump: 22 kW</p> <p>Mains frequency: 50 / 60 Hz</p> <p>Rated voltage: 3 x 380-480 V</p> <p>Rated current: 43.5-35.0 A</p> <p>Cos phi - power factor: 0.91-0.90</p> <p>Rated speed: 480-3540 rpm</p> <p>Efficiency: IE3 92,7%</p> <p>Motor efficiency at full load: 92.7 %</p> <p>Number of poles: 2</p> <p>Enclosure class (IEC 34-5): IP55</p> <p>Insulation class (IEC 85): F</p> <p>Motor No: 85901027</p> <p>Controls:</p> <p>Frequency converter: Built-in</p> <p>Pressure sensor: Y</p> <p>Others:</p> <p>Minimum efficiency index, MEI ≥: 0.70</p> <p>Net weight: 264 kg</p> <p>Gross weight: 327 kg</p> <p>Shipping volume: 1.14 m<sup>3</sup></p> <p>Danish VVS No.: 385949621</p> <p>Thrust handling device: N</p>

## 99264418 CRE 95-2-1 N-F-A-E-HQQE

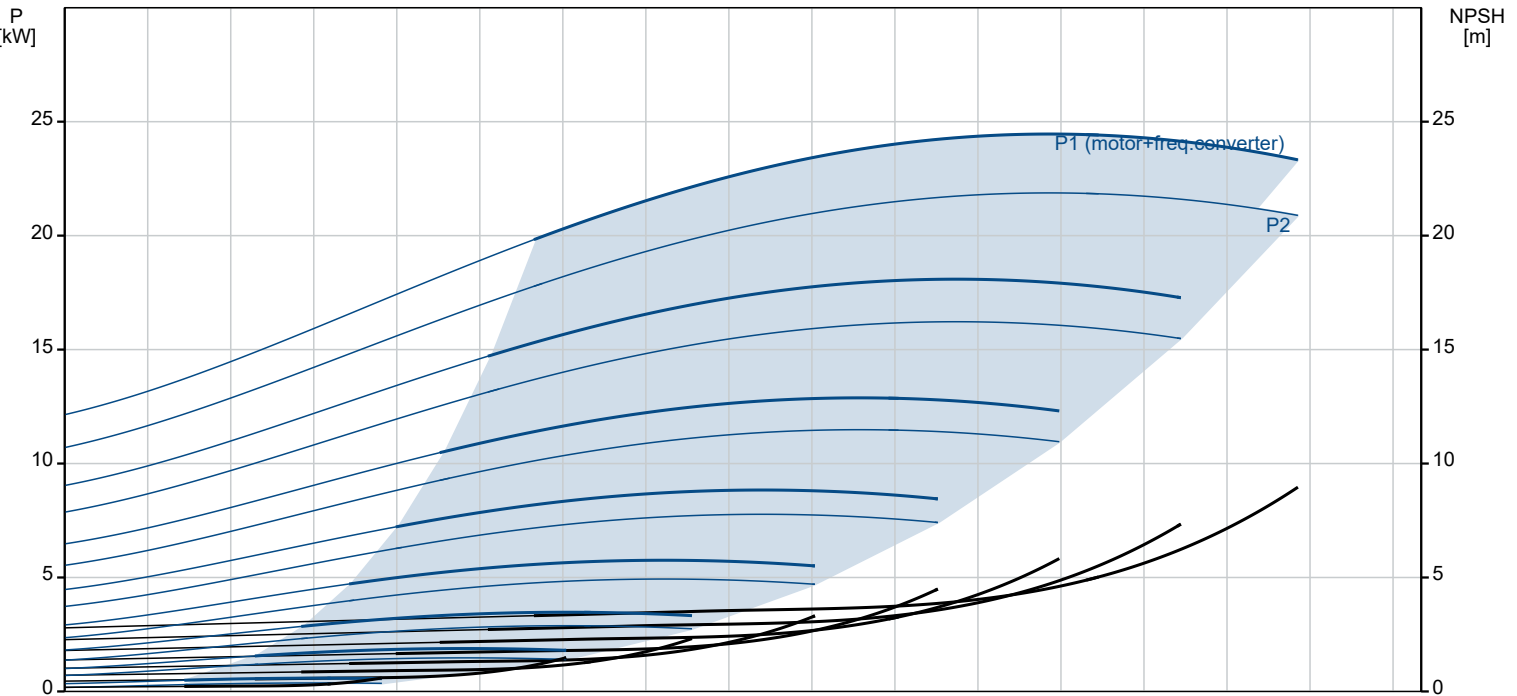
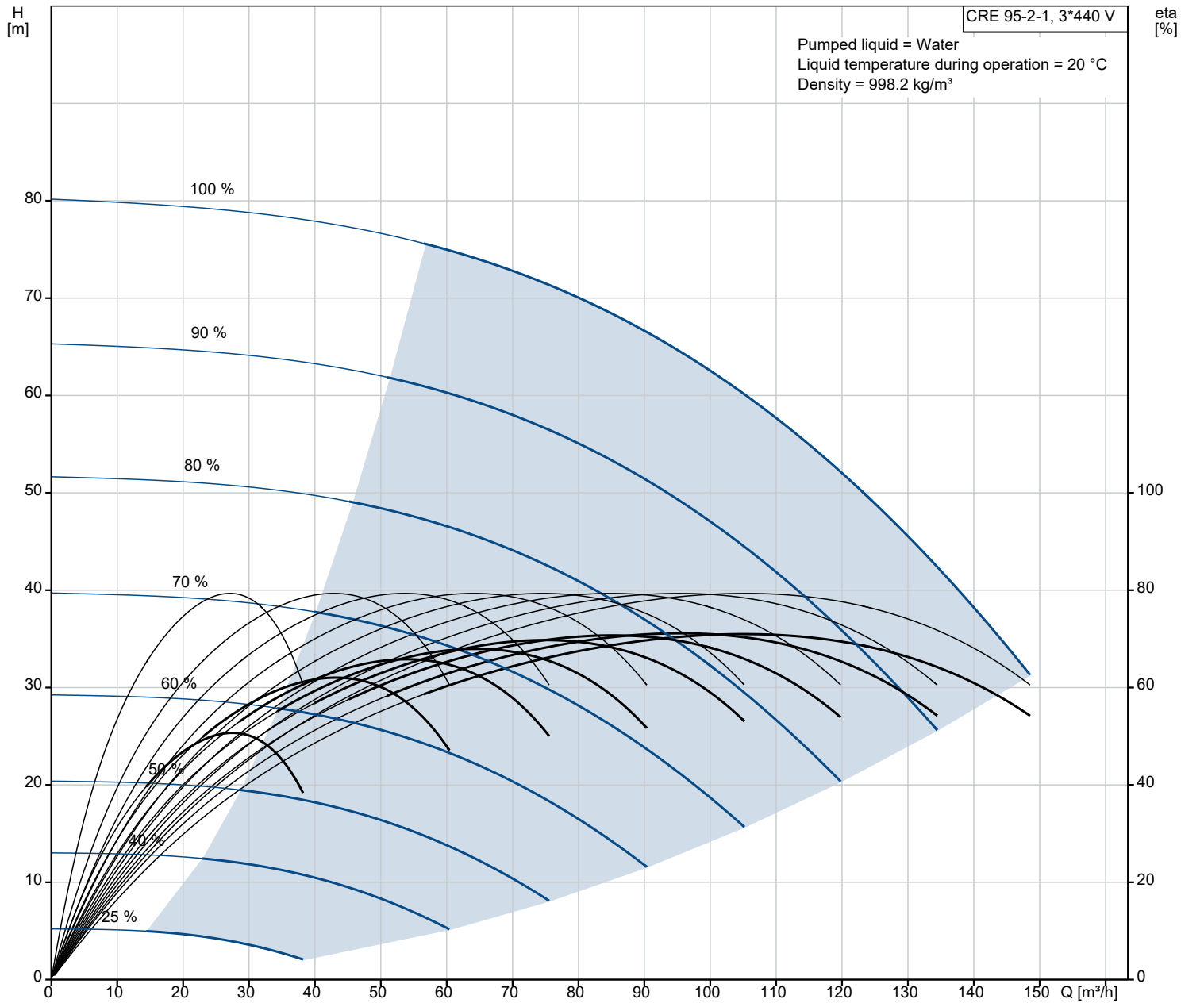

Description	Value
<b>General information:</b>	
Product name:	CRE 95-2-1 N-F-A-E-HQQE
Product No:	99264418
EAN number:	5713826224172
Price:	
<b>Technical:</b>	
Pump speed on which pump data are based:	3560 rpm
Rated flow:	114 m <sup>3</sup> /h
Rated head:	56.7 m
Maximum head:	80.5 m
Impellers:	2
Number of reduced-diameter impellers:	1
Low NPSH:	N
Pump orientation:	Vertical
Shaft seal arrangement:	Single
Code for shaft seal:	HQQE
Approvals:	CE,EAC,UKCA
Approvals for drinking water:	ACS,WRAS
Curve tolerance:	ISO9906:2012 3B
Pump version:	N
Model:	A
<b>Materials:</b>	
Base:	Ductile cast iron
Base:	EN 1563 EN-GJS-500-7
Base:	ASTM A536-84 65-45-12
Impeller:	Stainless steel
Impeller:	EN 1.4301
Impeller:	AISI 304
Material code:	A
Code for rubber:	E
Bearing:	WC/WC
Support bearing:	Graflon
Material certified according to:	European standards
<b>Installation:</b>	
t max amb:	40 °C
Maximum operating pressure:	16 bar
Max pressure at stated temp:	16 bar / 120 °C
Type of connection:	DIN
Size of inlet connection:	DN 100
Size of outlet connection:	DN 100
Pressure rating for connection:	PN 16
Flange size for motor:	FF300
Connect code:	F
<b>Liquid:</b>	
Pumped liquid:	Water
Liquid temperature range:	-20 .. 120 °C
Selected liquid temperature:	20 °C
Density:	998.2 kg/m <sup>3</sup>
<b>Electrical data:</b>	
Motor standard:	IEC
Motor type:	180MB
IE Efficiency class:	IE3
Rated power - P2:	22 kW
Power (P2) required by pump:	22 kW
Mains frequency:	50 / 60 Hz
Rated voltage:	3 x 380-480 V
Rated current:	43.5-35.0 A
Cos phi - power factor:	0.91-0.90
Rated speed:	480-3540 rpm
Efficiency:	IE3 92,7%
Motor efficiency at full load:	92.7 %
Number of poles:	2
Enclosure class (IEC 34-5):	IP55
Insulation class (IEC 85):	F
Built-in motor protection:	YES
Motor No:	85901027

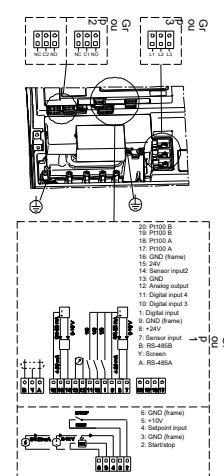
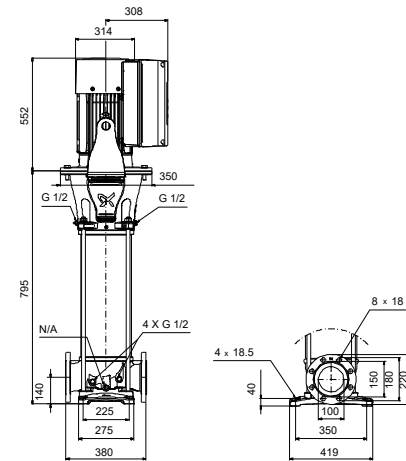
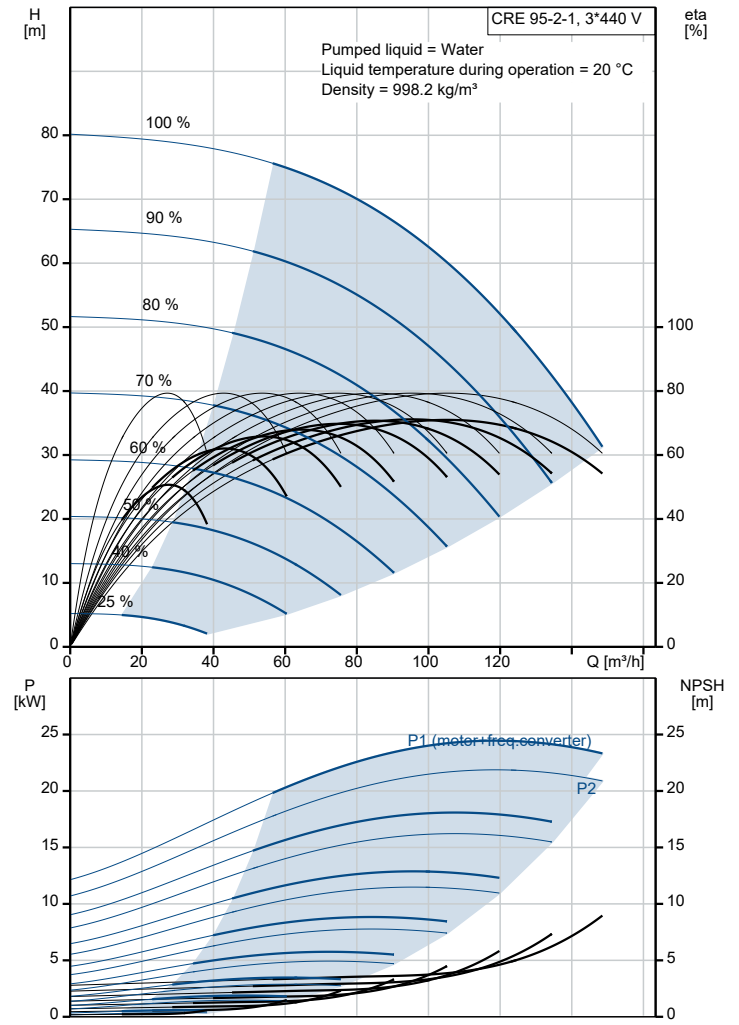

Description	Value
<b>Controls:</b>	
Function Module:	ADVANCED I/O
Frequency converter:	Built-in
Pressure sensor:	Y
<b>Others:</b>	
Minimum efficiency index, MEI $\geq$ :	0.70
Net weight:	264 kg
Gross weight:	327 kg
Shipping volume:	1.14 m <sup>3</sup>
Config. file no:	95139537
Danish VVS No.:	385949621
Thrust handling device:	N

## 99264418 CRE 95-2-1 N-F-A-E-HQQE

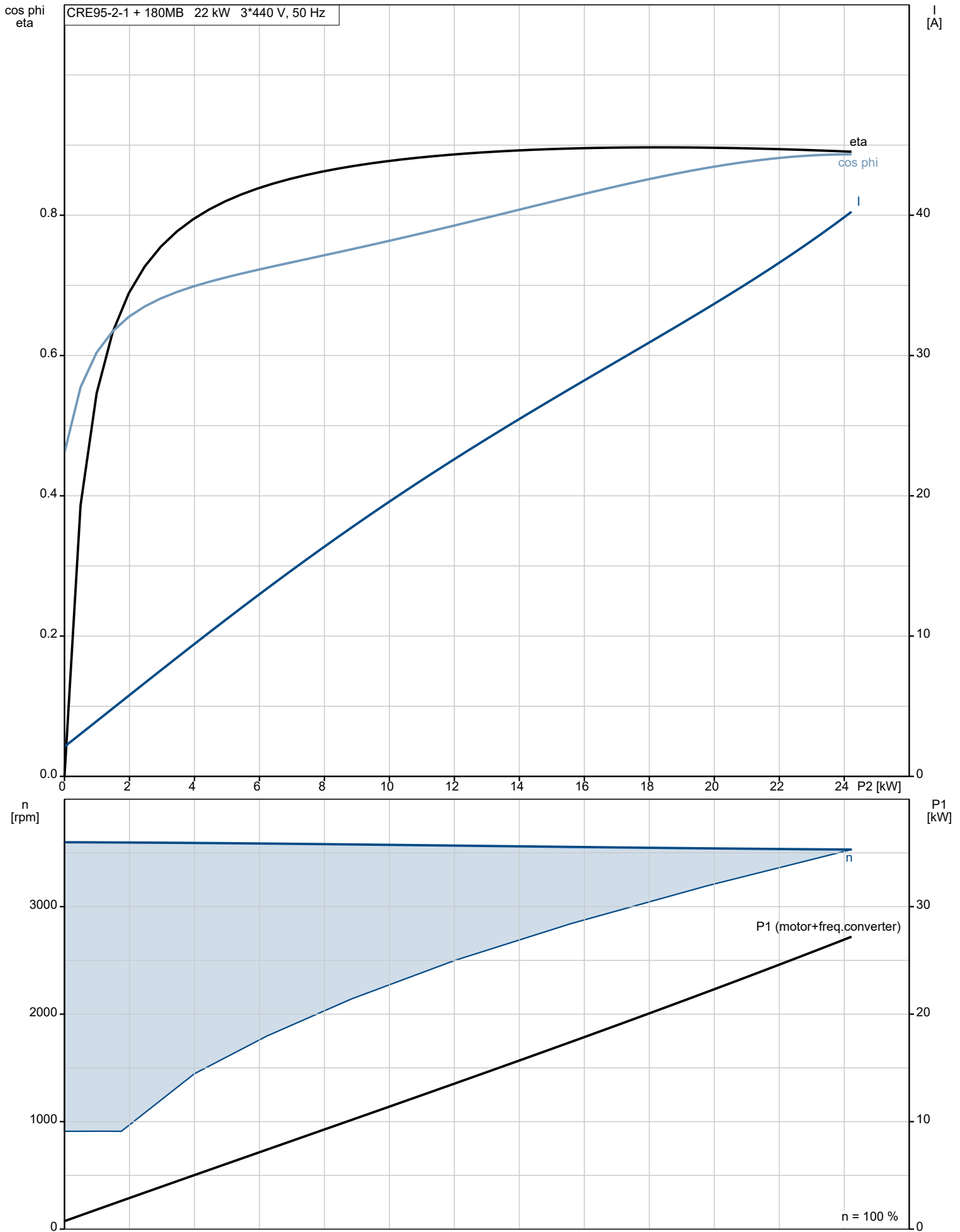

## 99264418 CRE 95-2-1 N-F-A-E-HQQE

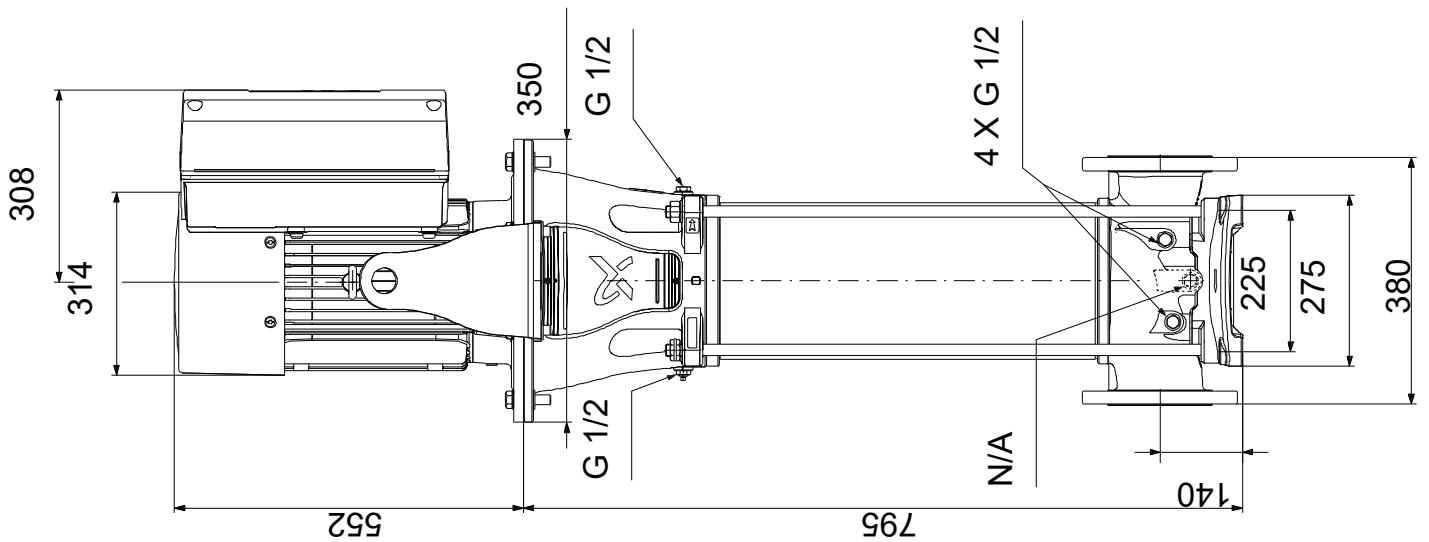



## 99264418 CRE 95-2-1 N-F-A-E-HQQE

