

Qty. Description

1 CME5-7 A-R-G-E-AQQE

Product No.: [99176057](#)

Compact, reliable, horizontal, multistage, end-suction centrifugal pump with axial suction port and radial discharge port. Pump materials in contact with the liquid are in high-grade stainless steel. The mechanical shaft seal is a special designed, unbalanced O-ring seal. Pipework connection is via internal Whitworth pipe threads, Rp (ISO 7/1).

The pump is fitted with a 3-phase, fan-cooled, permanent-magnet, synchronous motor. The motor efficiency is classified as IE5 in accordance with IEC 60034-30-2.

The motor includes a frequency converter and PI controller in the motor terminal box. This enables continuously variable control of the motor speed, which again enables adaptation of the performance to a given requirement.

An operating panel on the motor terminal box enables setting of required setpoint as well as setting of pump to "Min." or "Max." operation or to "Stop". The Grundfos Eye indicator on the operating panel provides visual indication of pump status:

- "Power on": Motor is running (rotating green indicator lights) or not running (permanently green indicator lights)
- "Warning": Motor is still running (rotating yellow indicator lights) or has stopped (permanently yellow indicator lights)
- "Alarm": Motor has stopped (flashing red indicator lights).

Communication with the pump is possible by means of Grundfos GO Remote (accessory). The remote control enables further settings as well as reading out of a number of parameters such as "Actual value", "Speed", "Power input" and total "Power consumption".

The terminal box holds terminals for these connections:

- one dedicated digital input
- two analog inputs, 0(4)-20 mA, 0-5 V, 0-10 V, 0.5 - 3.5 V
- 5 V voltage supply to potentiometer and sensor
- one configurable digital input or open-collector output
- Grundfos Digital Sensor input and output
- 24 V voltage supply for sensors
- two signal-relay outputs (potential-free contacts)
- GENIbus connection
- interface for Grundfos CIM fieldbus module.

Liquid:

Pumped liquid: Water
Liquid temperature range: -20 .. 120 °C
Selected liquid temperature: 20 °C
Density at selected liquid temperature: 998.2 kg/m³

Technical:

Pump speed on which pump data are based: 3480 rpm
Rated flow: 5.6 m³/h
Rated head: 78.4 m
Primary shaft seal: AQQE

99176057 CME5-7 A-R-G-E-AQQE 50 Hz

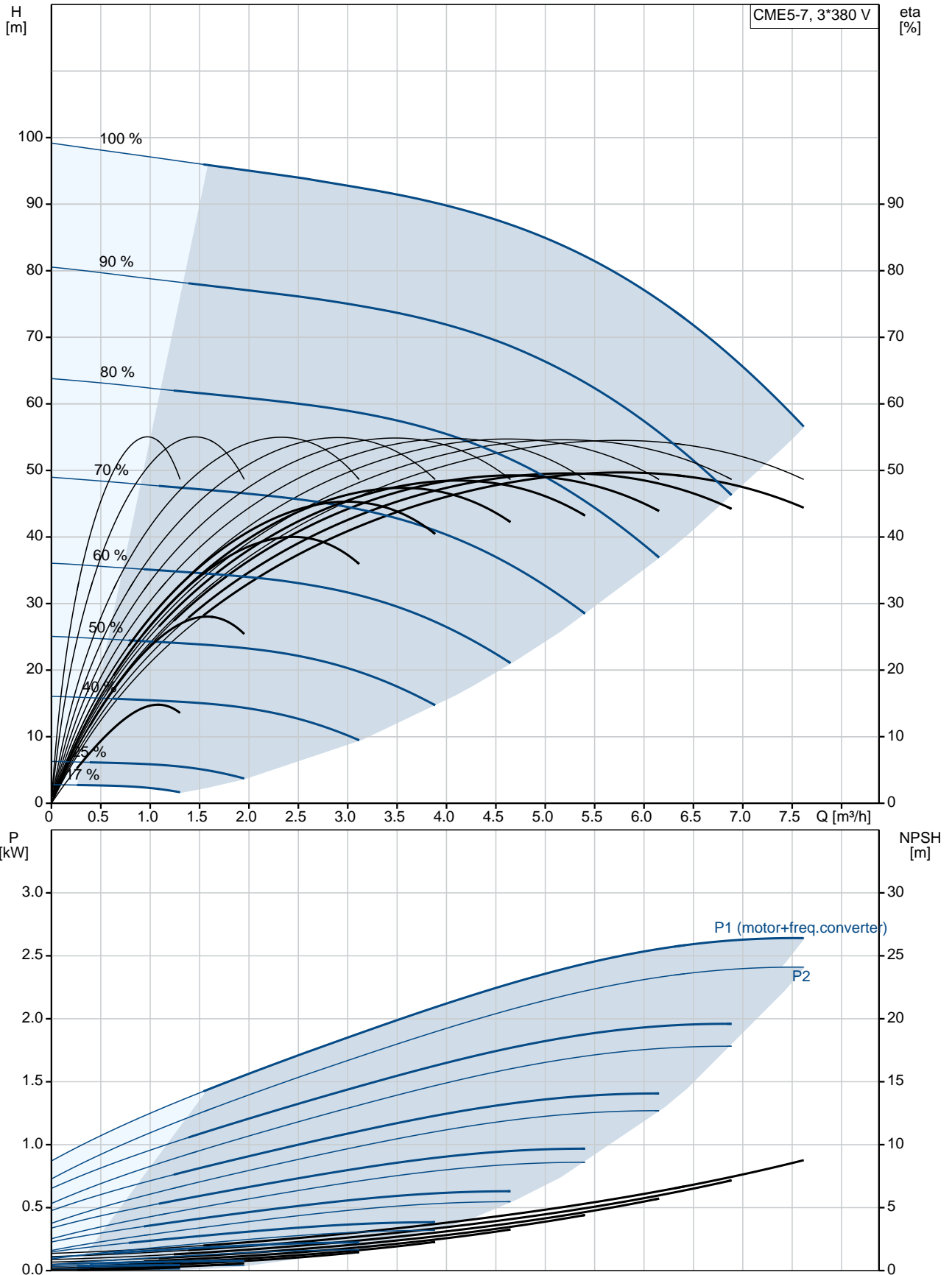

Description	Value
General information:	
Product name:	CME5-7 A-R-G-E-AQQE
Product No:	99176057
EAN number:	5712608130342
Technical:	
Pump speed on which pump data are based:	3480 rpm
Rated flow:	5.6 m ³ /h
Rated head:	78.4 m
Impellers:	7
Primary shaft seal:	AQQE
Approvals on nameplate:	CE,TR,EAC
Curve tolerance:	ISO9906:2012 3B
Pump version:	A
Model:	A
Materials:	
Pump housing:	Stainless steel
	DIN W.-Nr. 1.4401
	AISI 316
Impeller:	Stainless steel
	DIN W.-Nr. 1.4401
	AISI 316
Material code:	G
Rubber:	EPDM
Code for rubber:	E
Installation:	
Maximum ambient temperature:	40 °C
Maximum operating pressure:	16 bar
Max pressure at stated temp:	10 bar / 120 °C
	16 bar / 90 °C
Flange standard:	WHITWORTH THREAD
	RP
Pump inlet:	Rp 1 1/4
Pump outlet:	Rp 1
Connect code:	R
Liquid:	
Pumped liquid:	Water
Liquid temperature range:	-20 .. 120 °C
Selected liquid temperature:	20 °C
Density at selected liquid temperature:	998.2 kg/m ³
Electrical data:	
Motor type:	100A
IE Efficiency class:	IE5
Rated power - P2:	3 kW
Mains frequency:	50 Hz
Rated voltage:	3 x 380-500 V
Rated current:	5.80-4.80 A
Rated speed:	360-4000 rpm
Enclosure class (IEC 34-5):	IP55
Insulation class (IEC 85):	F
Others:	
Minimum efficiency index, MEI η_{min} :	0.7
Net weight:	29.3 kg
Gross weight:	32.8 kg
Config. file no:	99058872
Country of origin:	HU
Custom tariff no.:	84137075

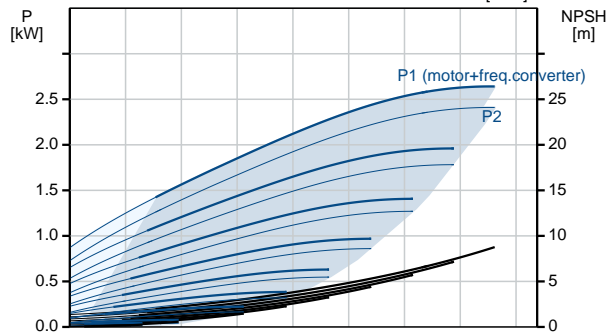
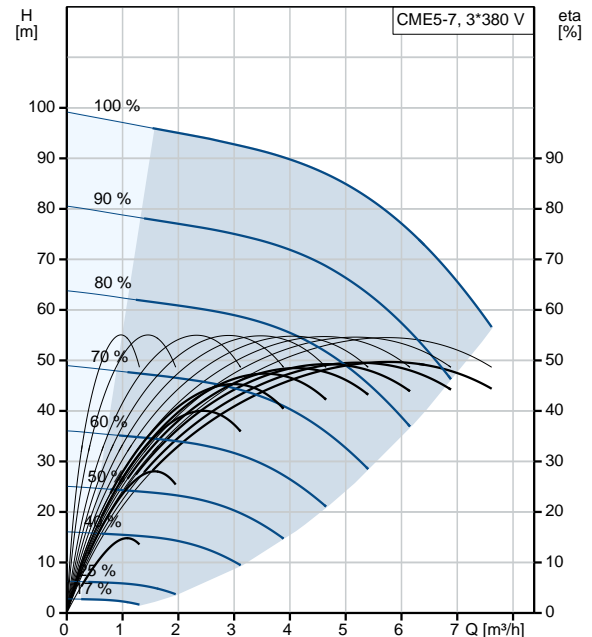

99176057 CME5-7 A-R-G-E-AQQE 50 Hz

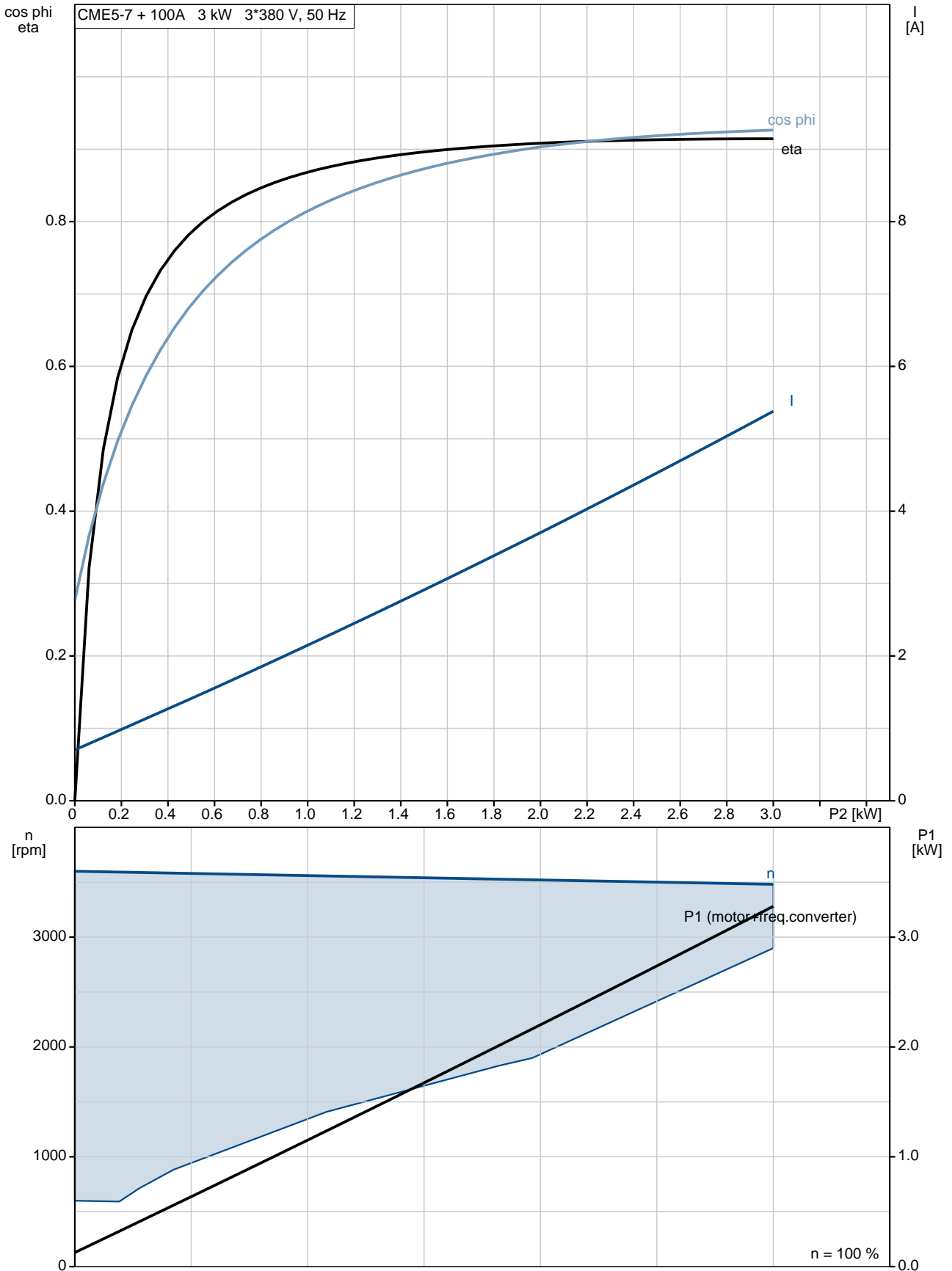

99176057 CME5-7 A-R-G-E-AQQE 50 Hz

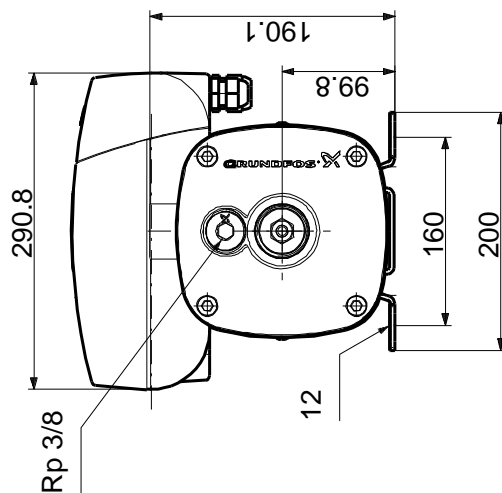
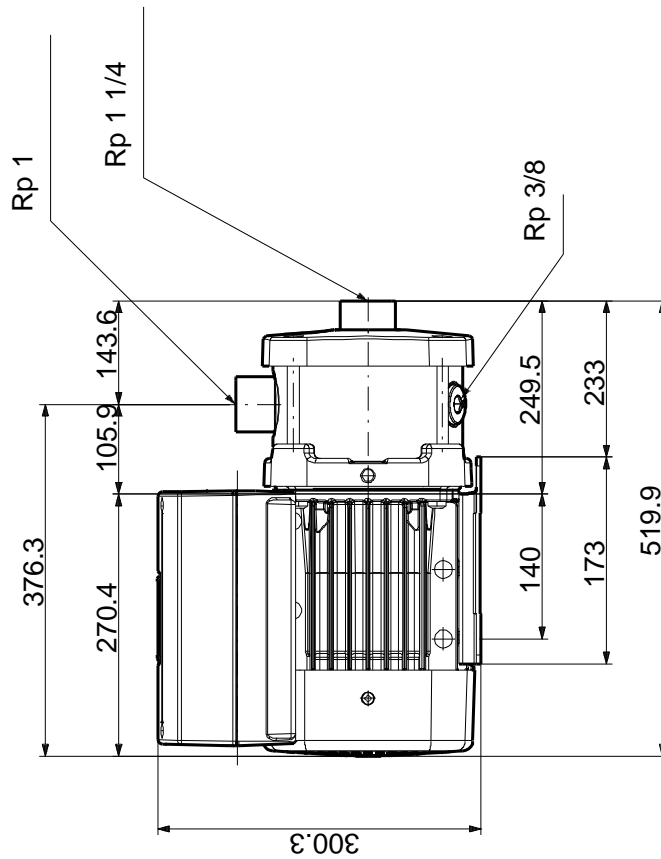

Note! All units are in [mm] unless others are stated.
Disclaimer: This simplified dimensional drawing does not show all details.

99176057 CME5-7 A-R-G-E-AQQE 50 Hz

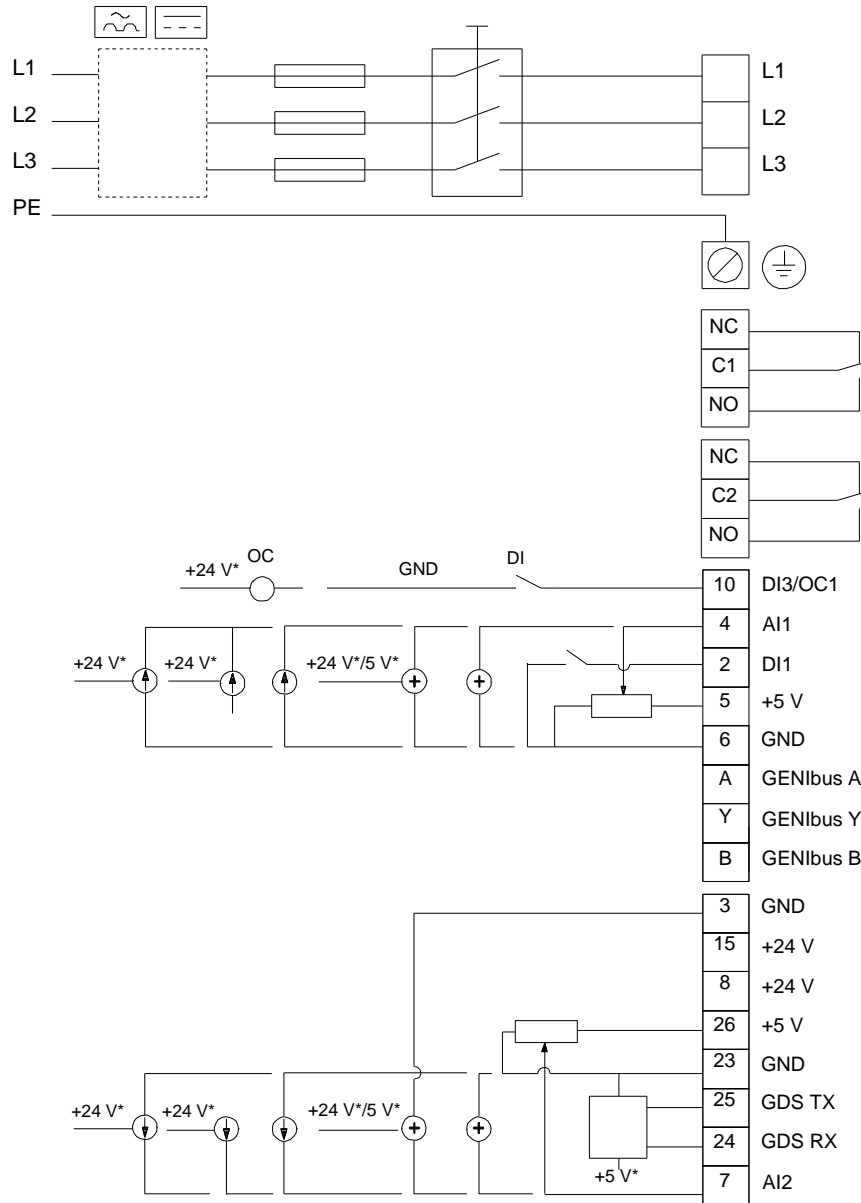

Note! All units are in [mm] unless others are stated.



Company name:

Created by:

Phone:

Date: 08/04/2019

Order Data:

Product name: CME5-7 A-R-G-E-AQQE

Amount: 1

Product No: 99176057

Total: Price on request
