

Position	Qty.	Description
	1	<p><b>CR 95-3-2 A-F-A-V-HQQV</b></p>  <p>Product No.: <a href="#">99141750</a></p> <p>Vertical, multistage centrifugal pump with suction and discharge ports on same the level (in-line) enabling installation in a horizontal one-pipe system. The pump head and base are in cast iron – all other wetted parts are in stainless steel. The Grundfos cartridge shaft seal ensures high reliability, safe handling, easy access and service.</p> <p>Power transmission is via a rigid split coupling. Pipework connection is via DIN flanges.</p> <p>The pump is fitted with a 3-phase, fan-cooled asynchronous motor.</p> <p><b>Liquid:</b></p> <p>Pumped liquid: Water            Liquid temperature range: -20 .. 90 °C            Liquid temperature during operation: 20 °C            Density: 998.2 kg/m<sup>3</sup></p> <p><b>Technical:</b></p> <p>Rated flow: 95 m<sup>3</sup>/h            Rated head: 53.7 m            Pump orientation: Vertical            Shaft seal arrangement: Single            Code for shaft seal: HQQV            Curve tolerance: ISO9906:2012 3B</p> <p><b>Materials:</b></p> <p>Base: Ductile cast iron            EN 1563 EN-GJS-500-7            Impeller: Stainless steel            EN 1.4301            Bearing: WC/WC            Support bearing: Graflon            Material certified according to: European standards</p> <p><b>Installation:</b></p> <p>Maximum ambient temperature: 60 °C            Maximum operating pressure: 16 bar            Max pressure at stated temp: 16 bar / 90 °C            Type of connection: DIN            Size of inlet connection: DN 100            Size of outlet connection: DN 100            Pressure rating for pipe connection: PN 16            Flange size for motor: FF300</p> <p><b>Electrical data:</b></p> <p>Motor standard: IEC            Motor type: 160LB            IE Efficiency class: IE3            Rated power - P2: 18.5 kW</p>

Position	Qty.	Description
		Power (P2) required by pump: 18.5 kW Mains frequency: 50 Hz Rated voltage: 3 x 380-415D/660-690Y V Rated current: 34,5-32,5/20,0-18,8 A Starting current: 830-980 % Cos phi - power factor: 0.89-0.85 Rated speed: 2940-2950 rpm Efficiency: IE3 92,4% Motor efficiency at full load: 92.4-92.4 % Motor efficiency at 3/4 load: 93.2 % Motor efficiency at 1/2 load: 93.2 % Number of poles: 2 Enclosure class (IEC 34-5): 55 Dust/Jetting Insulation class (IEC 85): F  <b>Controls:</b> Frequency converter: Not prepared for VFD  <b>Others:</b> Net weight: 224 kg Gross weight: 271 kg Shipping volume: 0.819 m <sup>3</sup> Thrust handling device: N Approvals: CE, EAC, ACS, WRAS

## 99141750 CR 95-3-2 A-F-A-V-HQQV 50 Hz

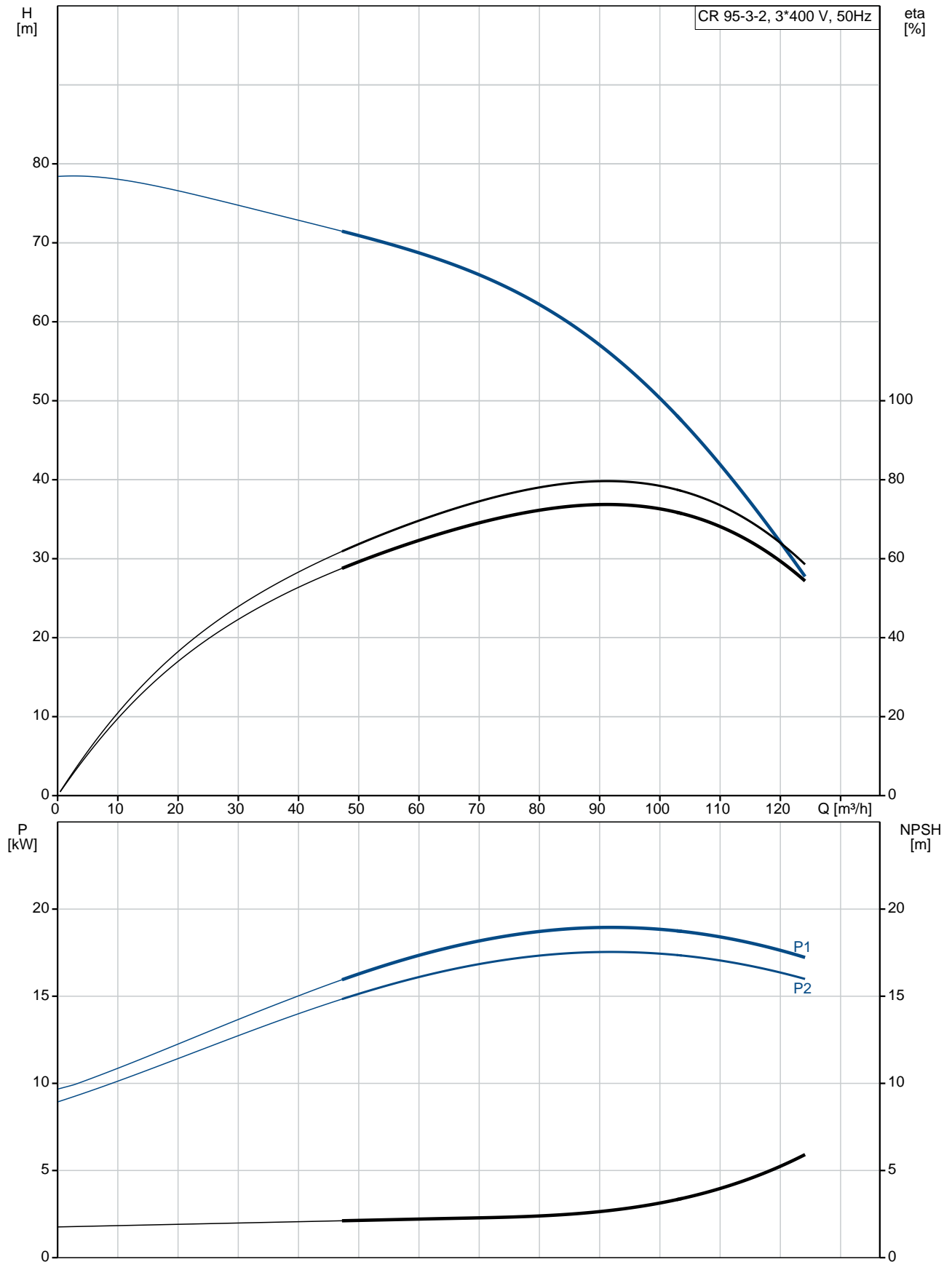

Description	Value
<b>General information:</b>	
Product name:	CR 95-3-2 A-F-A-V-HQQV
Product No:	99141750
EAN number:	5712607527433
<b>Technical:</b>	
Rated flow:	95 m <sup>3</sup> /h
Rated head:	53.7 m
Stages:	3
Impellers:	3
Number of reduced-diameter impellers:	2
Low NPSH:	N
Pump orientation:	Vertical
Shaft seal arrangement:	Single
Code for shaft seal:	HQQV
Curve tolerance:	ISO9906:2012 3B
Pump version:	A
Model:	A
Cooling:	IC 411
<b>Materials:</b>	
Base:	Ductile cast iron EN 1563 EN-GJS-500-7
Impeller:	Stainless steel EN 1.4301
Material code:	A
Code for rubber:	V
Bearing:	WC/WC
Support bearing:	Graflon
Material certified according to:	European standards
<b>Installation:</b>	
Maximum ambient temperature:	60 °C
Maximum operating pressure:	16 bar
Max pressure at stated temp:	16 bar / 90 °C
Type of connection:	DIN
Size of inlet connection:	DN 100
Size of outlet connection:	DN 100
Pressure rating for pipe connection:	PN 16
Flange size for motor:	FF300
Connect code:	F
<b>Liquid:</b>	
Pumped liquid:	Water
Liquid temperature range:	-20 .. 90 °C
Liquid temperature during operation:	20 °C
Density:	998.2 kg/m <sup>3</sup>
<b>Electrical data:</b>	
Motor standard:	IEC
Motor type:	160LB
IE Efficiency class:	IE3
Rated power - P2:	18.5 kW
Power (P2) required by pump:	18.5 kW
Mains frequency:	50 Hz
Rated voltage:	3 x 380-415D/660-690Y V
Rated current:	34,5-32,5/20,0-18,8 A
Starting current:	830-980 %
Cos phi - power factor:	0.89-0.85
Rated speed:	2940-2950 rpm
Efficiency:	IE3 92,4%
Motor efficiency at full load:	92.4-92.4 %

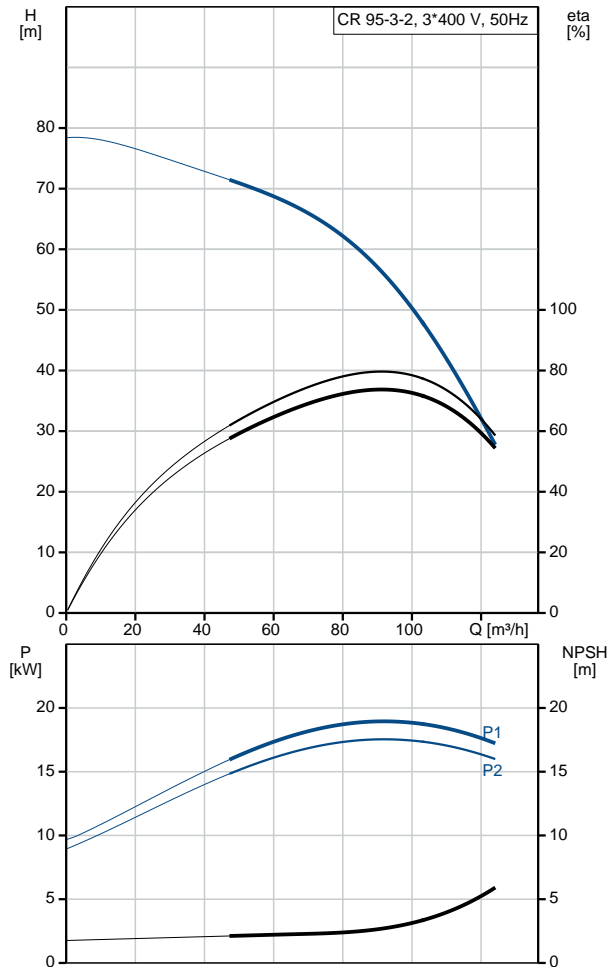



Company name:

Created by:

Phone:

Date: 12/09/2018

Description	Value
Motor efficiency at 3/4 load:	93.2 %
Motor efficiency at 1/2 load:	93.2 %
Number of poles:	2
Enclosure class (IEC 34-5):	55 Dust/Jetting
Insulation class (IEC 85):	F
Motor protec:	PTC
Motor No:	85U17528
<b>Controls:</b>	
Frequency converter:	Not prepared for VFD
<b>Others:</b>	
Net weight:	224 kg
Gross weight:	271 kg
Shipping volume:	0.819 m <sup>3</sup>
Thrust handling device:	N
Approvals:	CE, EAC, ACS, WRAS

**99141750 CR 95-3-2 A-F-A-V-HQQV 50 Hz**

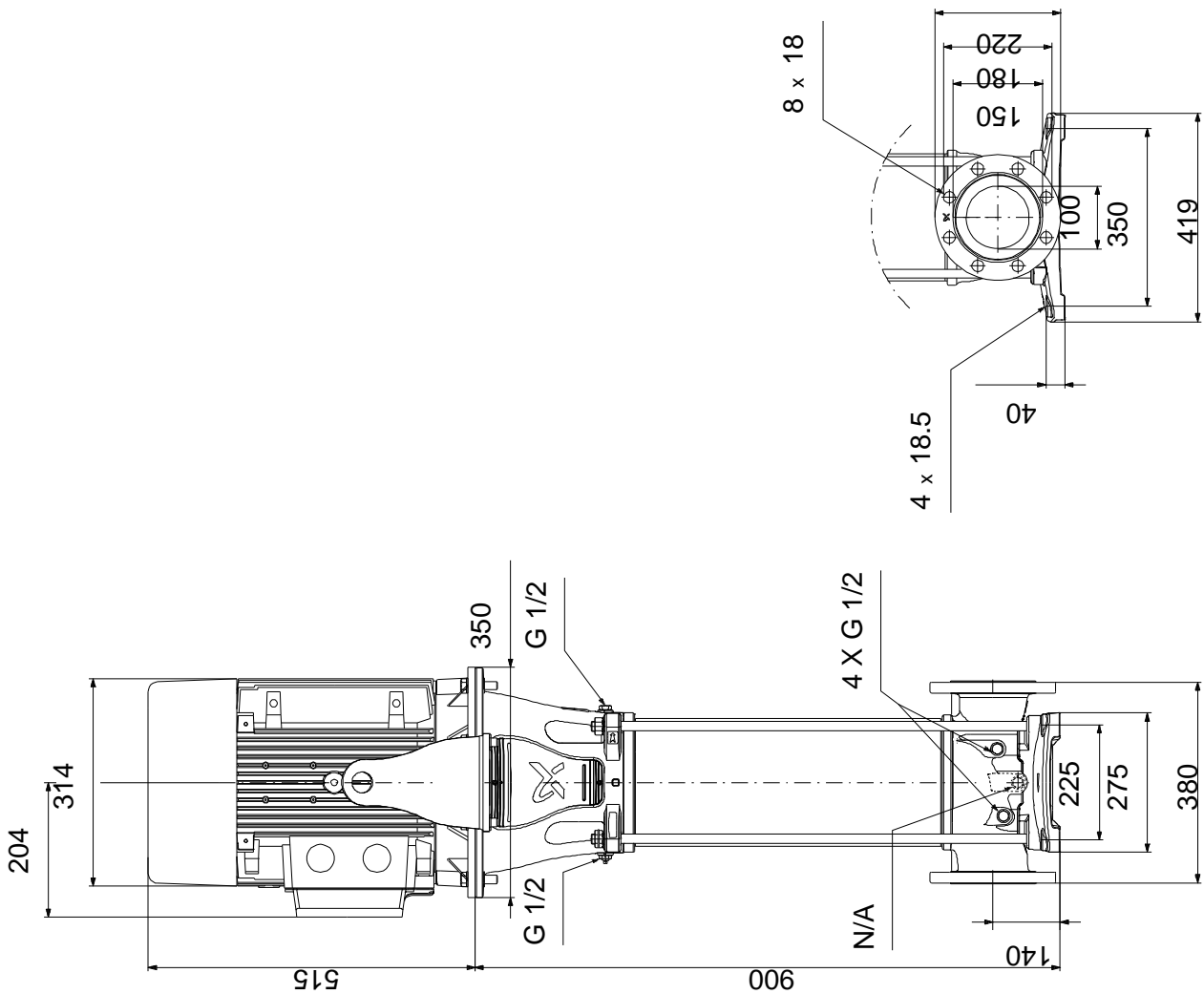

Note! All units are in [mm] unless others are stated.  
 Disclaimer: This simplified dimensional drawing does not show all details.

## 99141750 CR 95-3-2 A-F-A-V-HQQV 50 Hz

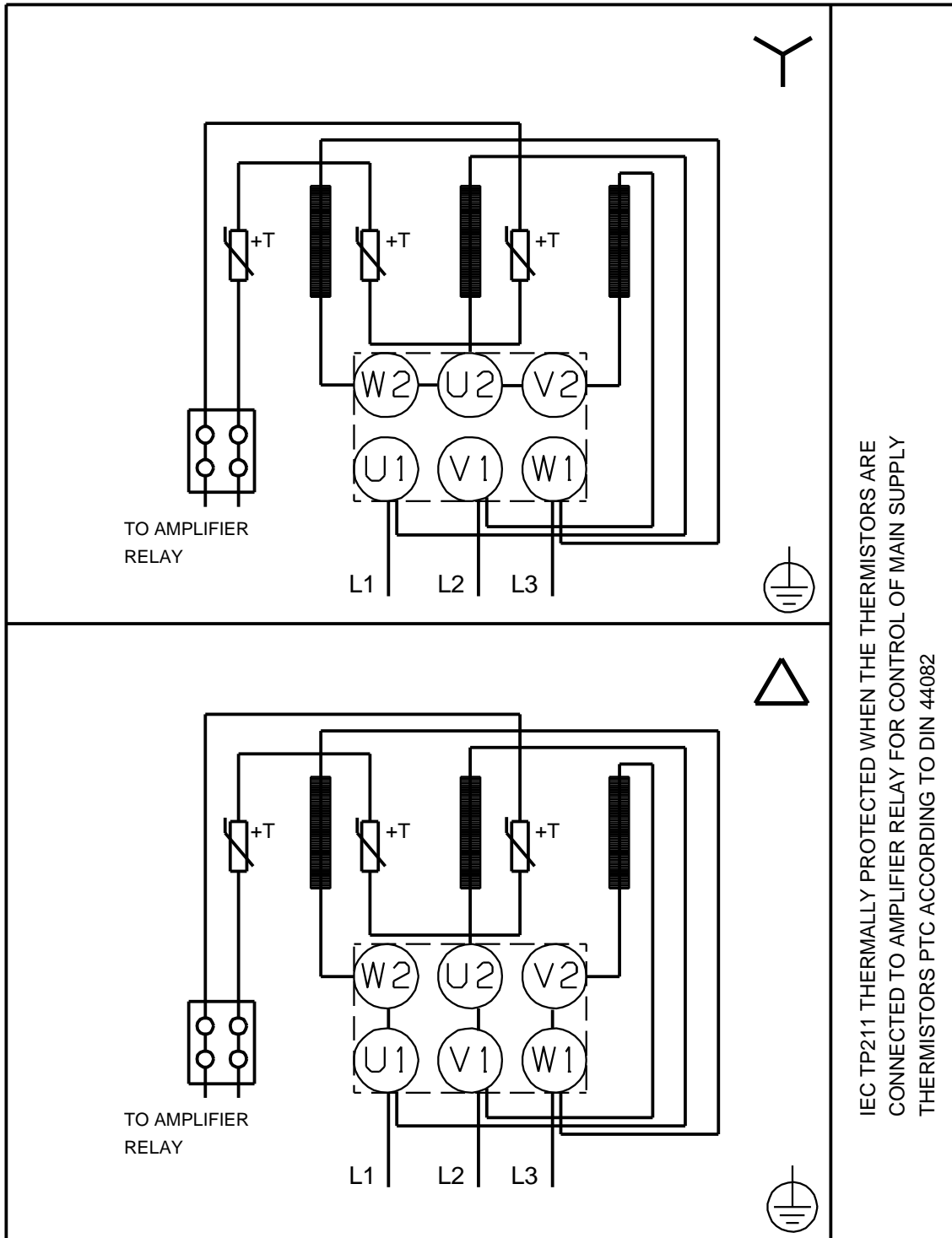

IEC TP211 THERMALLY PROTECTED WHEN THE THERMISTORS ARE  
CONNECTED TO AMPLIFIER RELAY FOR CONTROL OF MAIN SUPPLY  
THERMISTORS PTC ACCORDING TO DIN 44082

Note! All units are in [mm] unless others are stated.