

Position	Qty.	Description
	1	<p>TPD 32-40/4 A-F-A-BQQE</p>  <p>Product No.: 98958184</p> <p>Single-stage, close-coupled, volute twin-head pump with in-line suction and discharge ports of identical diameter. The twin-head pump is designed with two parallel power-heads. The pump is of the top-pull-out design, i.e. the power head (motor, pump head and impeller) can be removed for maintenance or service while the pump housing remains in the pipework.</p> <p>Each power head is fitted with an unbalanced rubber bellows seal. The shaft seal is according to EN 12756. Pipework connection is via PN 6/10 DIN flanges (EN 1092-2 and ISO 7005-2).</p> <p>Each power head is fitted with a fan-cooled asynchronous motor of identical size.</p> <p>Liquid:</p> <p>Pumped liquid: Water Liquid temperature range: -25 .. 120 °C Liquid temperature during operation: 20 °C Density: 998.2 kg/m³</p> <p>Technical:</p> <p>Rated flow: 3.4 m³/h Rated head: 2.8 m Actual impeller diameter: 118 mm Primary shaft seal: BQQE Curve tolerance: ISO9906:2012 3B</p> <p>Materials:</p> <p>Pump housing: Cast iron EN-JL1040 ASTM A48-40 B Impeller: Stainless steel DIN W.-Nr. 1.4301 AISI 304</p> <p>Installation:</p> <p>Range of ambient temperature: -30 .. 40 °C Maximum operating pressure: 10 bar Flange standard: DIN Pipe connection: DN 32 Pump inlet: DN 32 Pump outlet: DN 32 Pressure rating: PN 6/10 (@): 280 mm Flange size for motor: FT85</p> <p>Electrical data:</p> <p>Motor type: 71A Rated power - P2: 2 x 0.25 kW Mains frequency: 50 Hz Rated voltage: 3 x 220-240D/380-415Y V Rated current: 1.48/0.85 A</p>



Company name:

Created by:

Phone:

Date:

05/10/2018

Position	Qty.	Description
		Starting current: 400-440 % Cos phi - power factor: 0.75-0.65 Rated speed: 1400-1420 rpm Efficiency: 61,5% - 68,5% Motor efficiency at full load: 61.5-68.5 % Motor efficiency at 3/4 load: 70 % Motor efficiency at 1/2 load: 63.9 % Number of poles: 4 Enclosure class (IEC 34-5): 55 Dust/Jetting Insulation class (IEC 85): F Others: ErP status: EuP Standalone/Prod. Net weight: 50.8 kg Gross weight: 57.8 kg Shipping volume: 0.12 m ³

98958184 TPD 32-40/4 A-F-A-BQQE 50 Hz

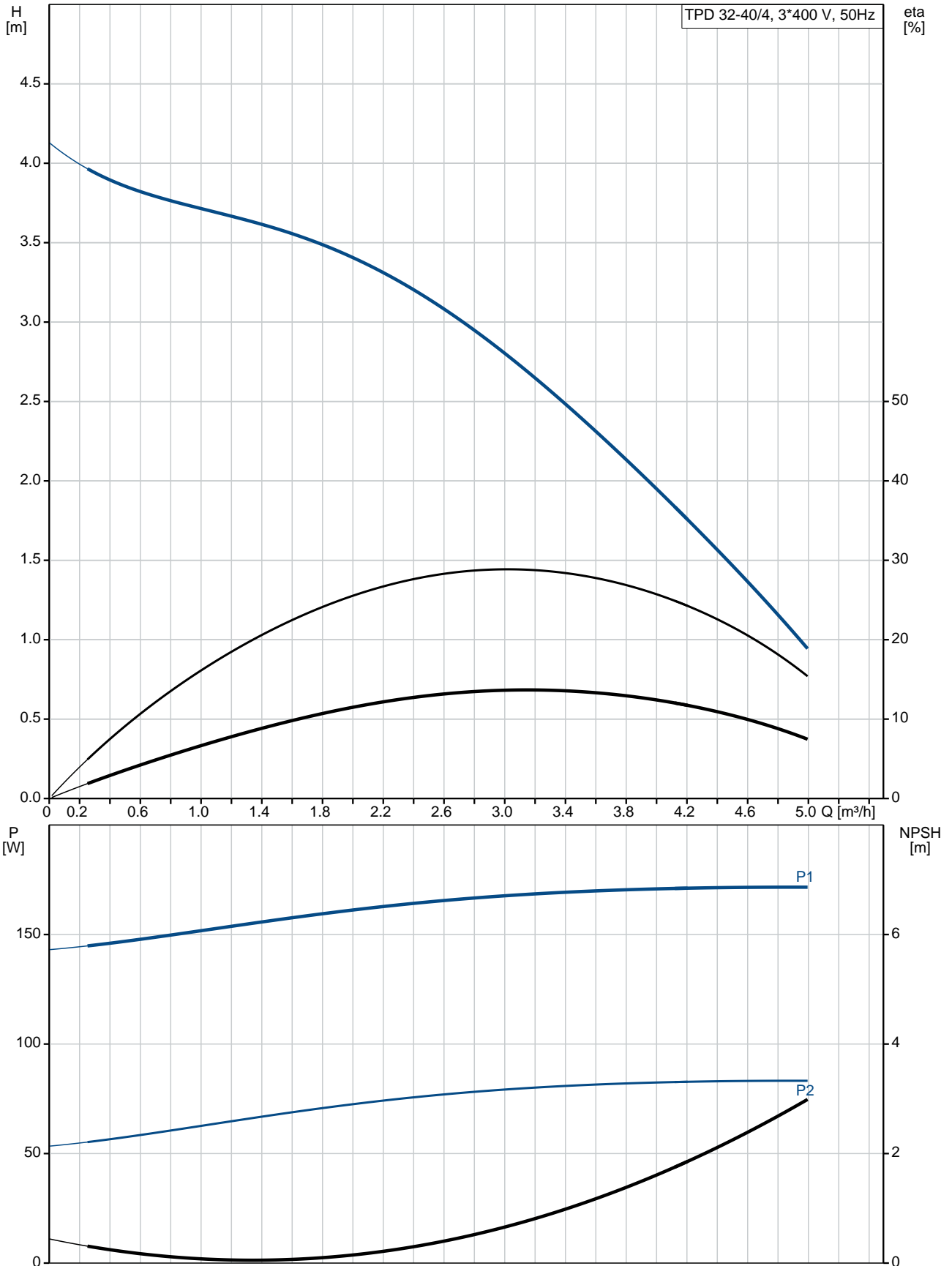

Description	Value
General information:	
Product name:	TPD 32-40/4 A-F-A-BQQE
Product No:	98958184
EAN number:	5712604246528
Technical:	
Rated flow:	3.4 m³/h
Rated head:	2.8 m
Head max:	40 dm
Actual impeller diameter:	118 mm
Primary shaft seal:	BQQE
Curve tolerance:	ISO9906:2012 3B
Pump version:	A
Model:	A
Materials:	
Pump housing:	Cast iron EN-JL1040
	ASTM A48-40 B
Impeller:	Stainless steel DIN W.-Nr. 1.4301 AISI 304
Material code:	A
Installation:	
Range of ambient temperature:	-30 .. 40 °C
Maximum operating pressure:	10 bar
Flange standard:	DIN
Pipe connection:	DN 32
Pump inlet:	DN 32
Pump outlet:	DN 32
Pressure rating:	PN 6/10
(@)	280 mm
Flange size for motor:	FT85
Connect code:	F
Liquid:	
Pumped liquid:	Water
Liquid temperature range:	-25 .. 120 °C
Liquid temperature during operation:	20 °C
Density:	998.2 kg/m³
Electrical data:	
Motor type:	71A
Rated power - P2:	2 x 0.25 kW
Mains frequency:	50 Hz
Rated voltage:	3 x 220-240D/380-415Y V
Rated current:	1.48/0.85 A
Starting current:	400-440 %
Cos phi - power factor:	0.75-0.65
Rated speed:	1400-1420 rpm
Efficiency:	61,5% - 68,5%
Motor efficiency at full load:	61.5-68.5 %
Motor efficiency at 3/4 load:	70 %
Motor efficiency at 1/2 load:	63.9 %
Number of poles:	4
Enclosure class (IEC 34-5):	55 Dust/Jetting
Insulation class (IEC 85):	F
Motor protec:	NONE
Motor No:	86805101
Others:	
ErP status:	EuP Standalone/Prod.
Net weight:	50.8 kg

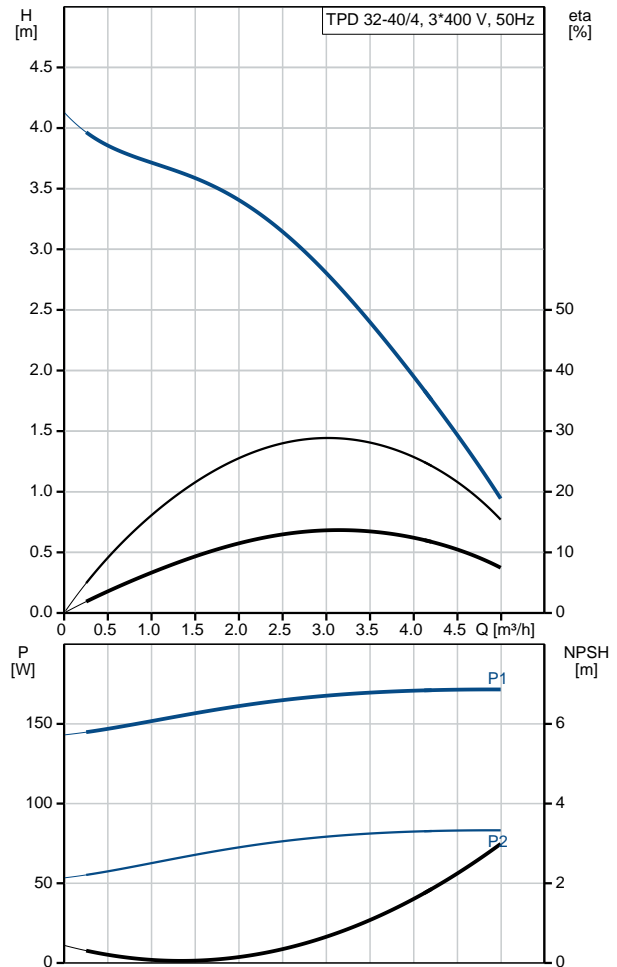



Company name:

Created by:

Phone:

Date:

05/10/2018

Description	Value
Gross weight:	57.8 kg
Shipping volume:	0.12 m ³

98958184 TPD 32-40/4 A-F-A-BQQE 50 Hz

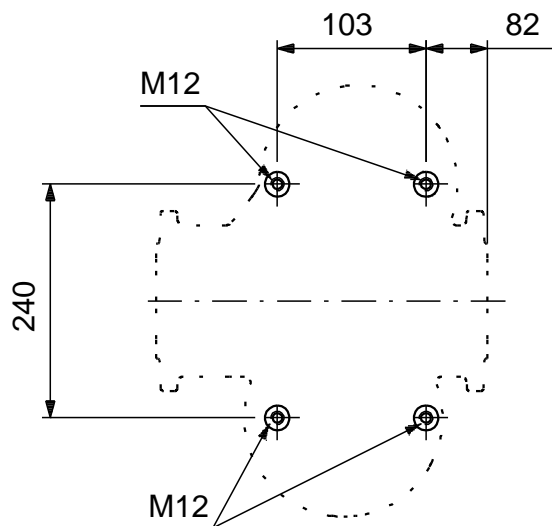
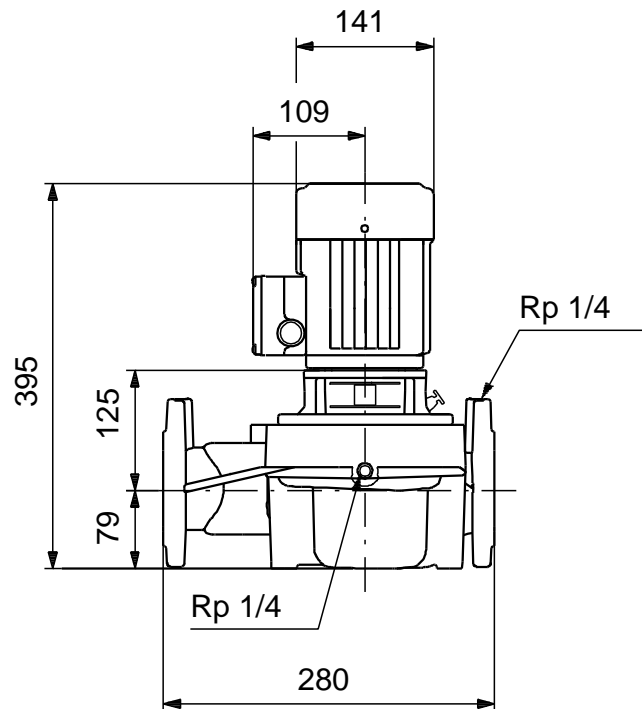
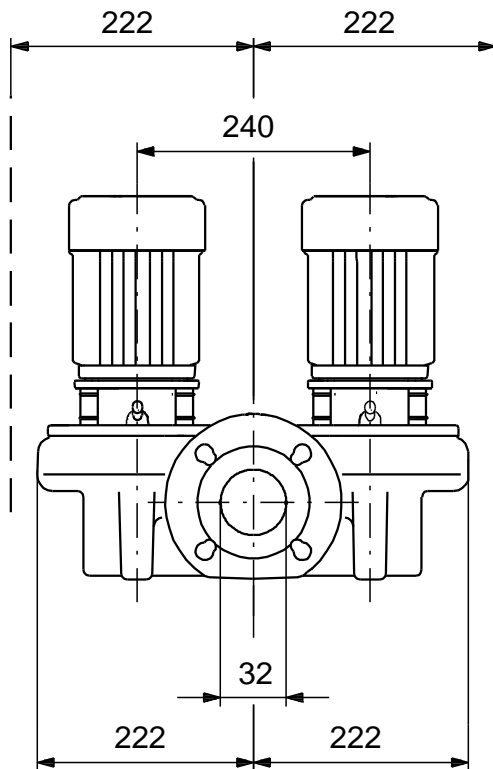

Note! All units are in [mm] unless others are stated.
Disclaimer: This simplified dimensional drawing does not show all details.

98958184 TPD 32-40/4 A-F-A-BQQE 50 Hz

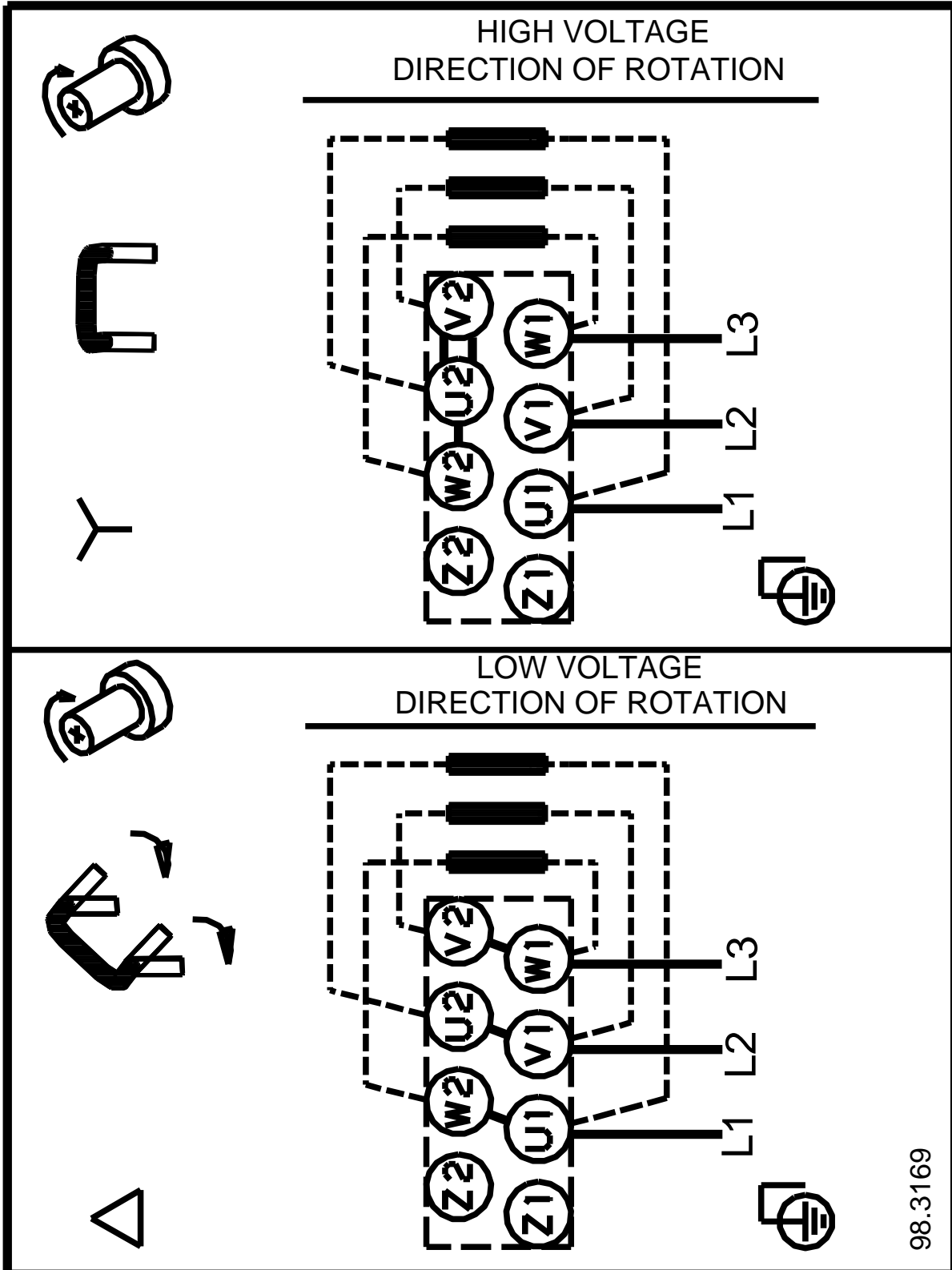

98.3169

Note! All units are in [mm] unless others are stated.