

Position	Qty.	Description
	1	<p><b>TPD 50-180/2 A-F-A-BQQE</b></p>  <p>Product No.: <a href="#">98957984</a></p> <p>Single-stage, close-coupled, volute twin-head pump with in-line suction and discharge ports of identical diameter. The twin-head pump is designed with two parallel power-heads. The pump is of the top-pull-out design, i.e. the power head (motor, pump head and impeller) can be removed for maintenance or service while the pump housing remains in the pipework.</p> <p>Each power head is fitted with an unbalanced rubber bellows seal. The shaft seal is according to EN 12756. Pipework connection is via PN 6/10 DIN flanges (EN 1092-2 and ISO 7005-2).</p> <p>Each power head is fitted with a fan-cooled asynchronous motor of identical size.</p> <p><b>Liquid:</b></p> <p>Pumped liquid: Water            Liquid temperature range: -25 .. 120 °C            Liquid temperature during operation: 20 °C            Density: 998.2 kg/m<sup>3</sup></p> <p><b>Technical:</b></p> <p>Rated flow: 18.3 m<sup>3</sup>/h            Rated head: 10.2 m            Actual impeller diameter: 100 mm            Primary shaft seal: BQQE            Curve tolerance: ISO9906:2012 3B</p> <p><b>Materials:</b></p> <p>Pump housing: Cast iron            EN-JL1040            ASTM A48-40 B</p> <p>Impeller: Stainless steel            DIN W.-Nr. 1.4301            AISI 304</p> <p><b>Installation:</b></p> <p>Range of ambient temperature: -30 .. 40 °C            Maximum operating pressure: 10 bar            Flange standard: DIN            Pipe connection: DN 50            Pump inlet: DN 50            Pump outlet: DN 50            Pressure rating: PN 6/10            (@): 280 mm            Flange size for motor: FT100</p> <p><b>Electrical data:</b></p> <p>Motor type: 80B            Rated power - P2: 2 x 0.75 kW            Mains frequency: 50 Hz            Rated voltage: 1 x 220-230/240 V            Rated current: 5.10/4.75 A</p>



Company name:

Created by:

Phone:

Date:

11/10/2018

Position	Qty.	Description
		Starting current: 300 % Cos phi - power factor: 0.99 Rated speed: 2780 rpm Efficiency: 72.1% Motor efficiency at full load: 72.1 % Number of poles: 2 Enclosure class (IEC 34-5): 55 Dust/Jetting Insulation class (IEC 85): F  <b>Others:</b> Minimum efficiency index, MEI : 0.70 ErP status: EuP Standalone/Prod. Net weight: 63 kg Gross weight: 70 kg Shipping volume: 0.12 m <sup>3</sup> Country of origin: HU Custom tariff no.: 84137065

## 98957984 TPD 50-180/2 A-F-A-BQQE 50 Hz

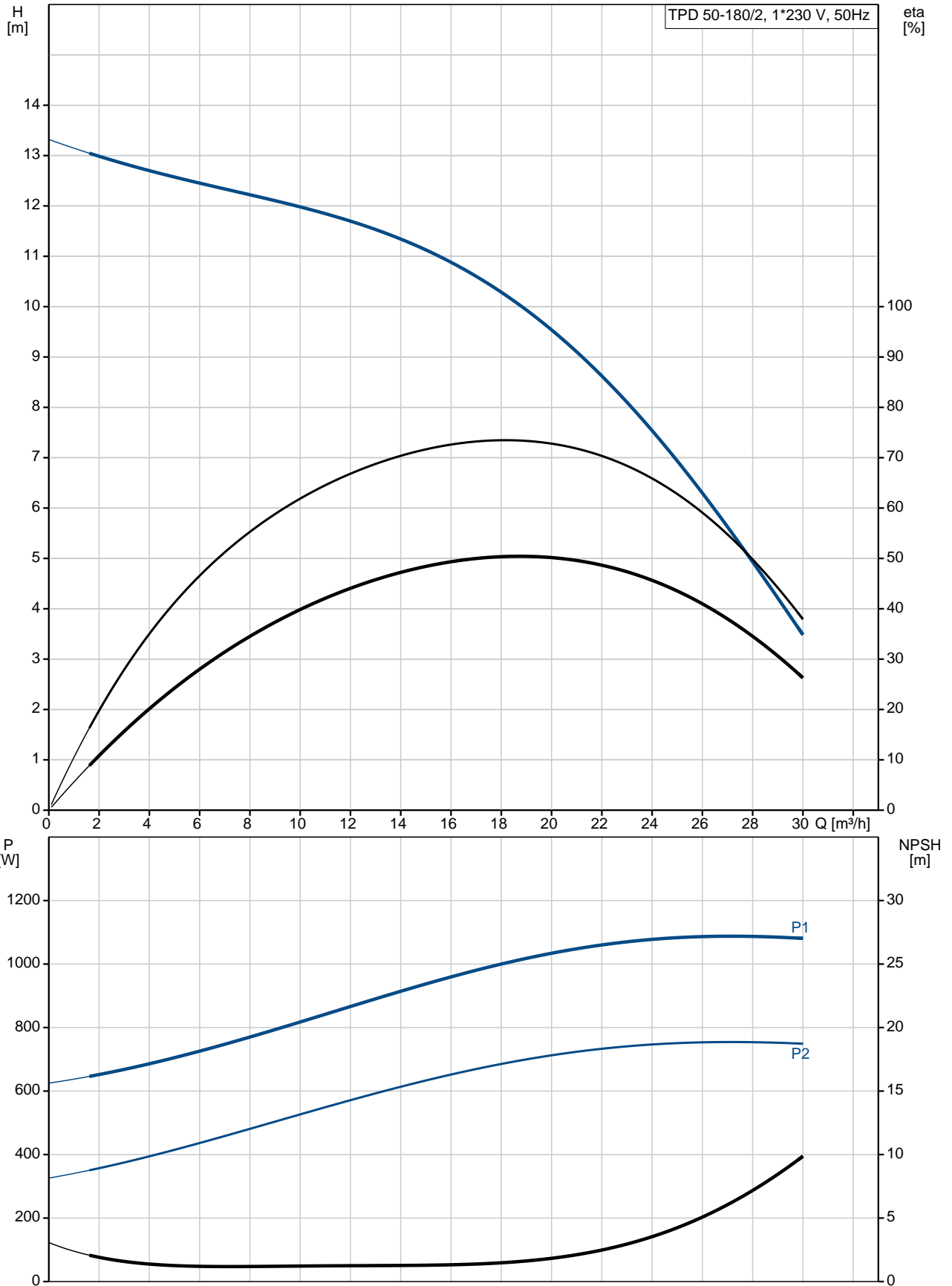

Description	Value
<b>General information:</b>	
Product name:	TPD 50-180/2 A-F-A-BQQE
Product No:	98957984
EAN number:	5712604244517
Price:	2.918,00 GBP
<b>Technical:</b>	
Rated flow:	18.3 m <sup>3</sup> /h
Rated head:	10.2 m
Head max:	180 dm
Actual impeller diameter:	100 mm
Primary shaft seal:	BQQE
Curve tolerance:	ISO9906:2012 3B
Pump version:	A
Model:	A
<b>Materials:</b>	
Pump housing:	Cast iron EN-JL1040
	ASTM A48-40 B
Impeller:	Stainless steel DIN W.-Nr. 1.4301 AISI 304
Material code:	A
<b>Installation:</b>	
Range of ambient temperature:	-30 .. 40 °C
Maximum operating pressure:	10 bar
Flange standard:	DIN
Pipe connection:	DN 50
Pump inlet:	DN 50
Pump outlet:	DN 50
Pressure rating:	PN 6/10
(@)	280 mm
Flange size for motor:	FT100
Connect code:	F
<b>Liquid:</b>	
Pumped liquid:	Water
Liquid temperature range:	-25 .. 120 °C
Liquid temperature during operation:	20 °C
Density:	998.2 kg/m <sup>3</sup>
<b>Electrical data:</b>	
Motor type:	80B
Rated power - P2:	2 x 0.75 kW
Mains frequency:	50 Hz
Rated voltage:	1 x 220-230/240 V
Rated current:	5.10/4.75 A
Starting current:	300 %
Cos phi - power factor:	0.99
Rated speed:	2780 rpm
Efficiency:	72.1%
Motor efficiency at full load:	72.1 %
Number of poles:	2
Enclosure class (IEC 34-5):	55 Dust/Jetting
Insulation class (IEC 85):	F
Motor protec:	PTO
Motor No:	85215104
<b>Others:</b>	
Minimum efficiency index, MEI :	0.70
ErP status:	EuP Standalone/Prod.
Net weight:	63 kg

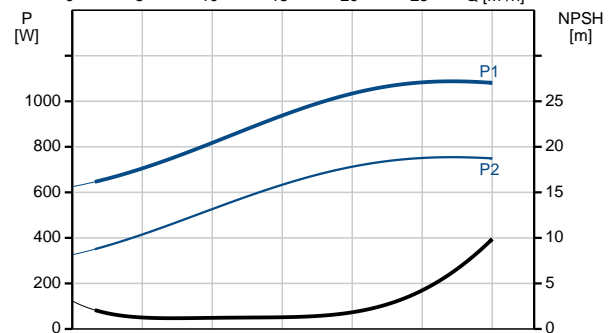
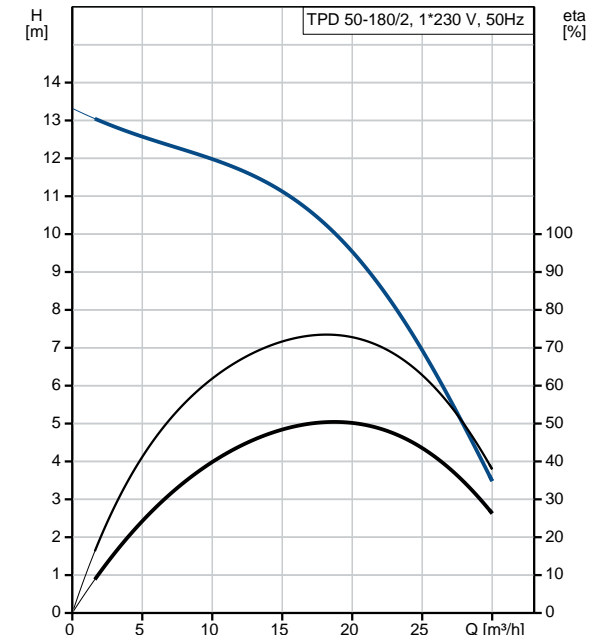



Company name:

Created by:

Phone:

Date:

11/10/2018

Description	Value
Gross weight:	70 kg
Shipping volume:	0.12 m <sup>3</sup>
Country of origin:	HU
Custom tariff no.:	84137065

**98957984 TPD 50-180/2 A-F-A-BQQE 50 Hz**

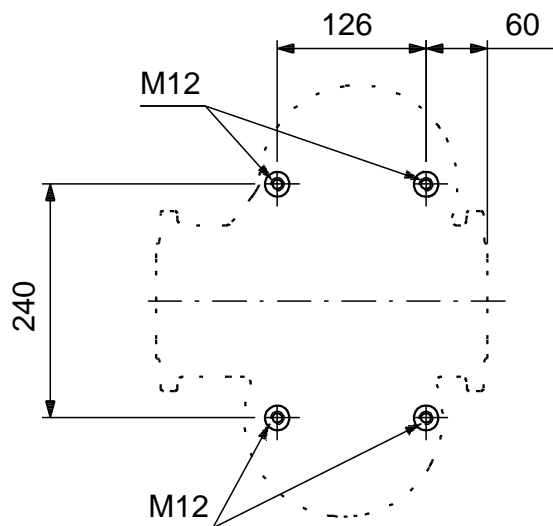
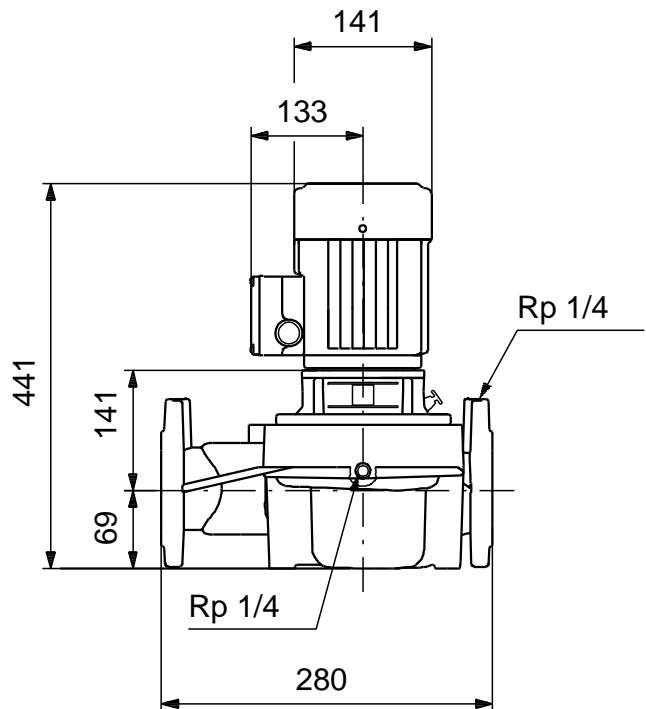
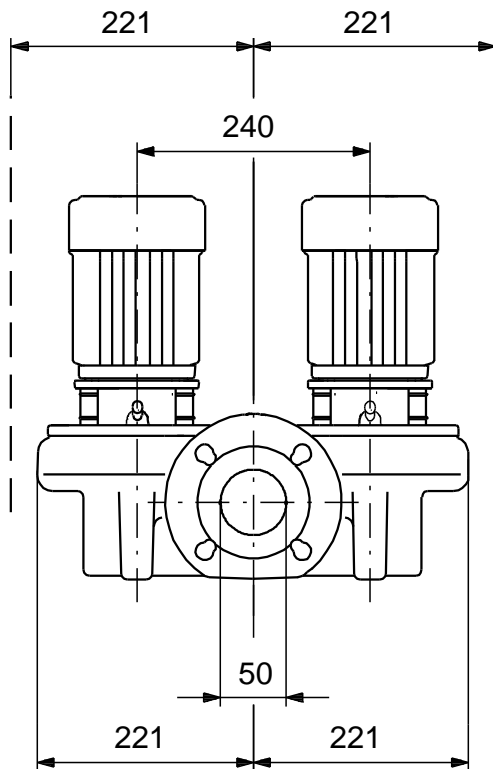

Note! All units are in [mm] unless others are stated.  
Disclaimer: This simplified dimensional drawing does not show all details.

## 98957984 TPD 50-180/2 A-F-A-BQQE 50 Hz

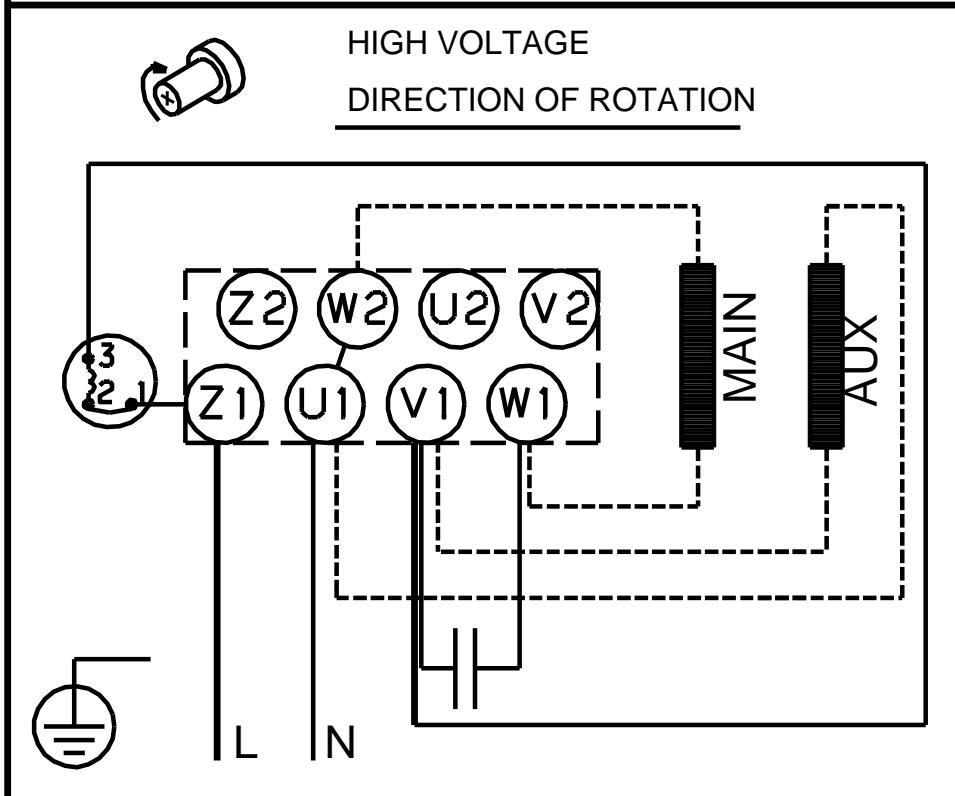
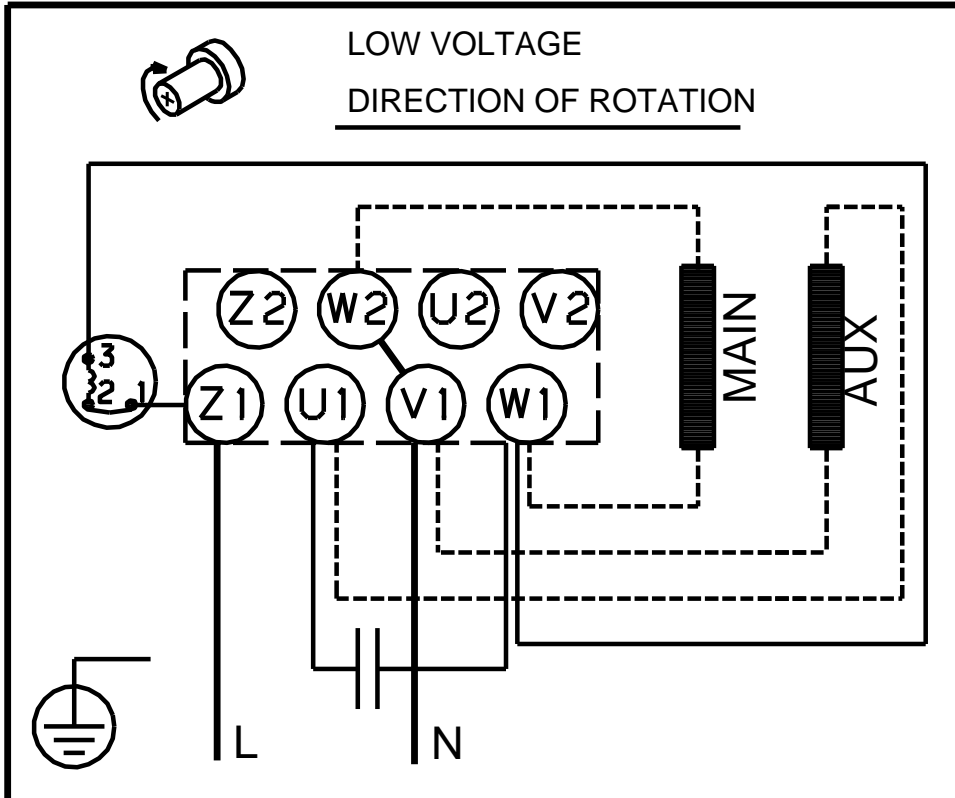

Note! All units are in [mm] unless others are stated.