

Position	Qty.	Description
	1	<p>TP 40-180/2 A-F-A-BQQE</p>  <p>Product No.: 98957965</p> <p>Single-stage, close-coupled, volute pump with in-line suction and discharge ports of identical diameter. The pump is of the top-pull-out design, i.e. the power head (motor, pump head and impeller) can be removed for maintenance or service while the pump housing remains in the pipework.</p> <p>The pump is fitted with an unbalanced rubber bellows seal. The shaft seal is according to EN 12756. Pipework connection is via PN 6/10 DIN flanges (EN 1092-2 and ISO 7005-2).</p> <p>The pump is fitted with a fan-cooled asynchronous motor.</p> <p>Liquid: Pumped liquid: Water Liquid temperature range: -25 .. 120 °C Liquid temperature during operation: 20 °C Density: 998.2 kg/m³</p> <p>Technical: Speed for pump data: 2860 rpm Rated flow: 12.5 m³/h Rated head: 10 m Actual impeller diameter: 98 mm Primary shaft seal: BQQE Curve tolerance: ISO9906:2012 3B</p> <p>Materials: Pump housing: Cast iron EN-JL1040 ASTM A48-40 B Impeller: Stainless steel DIN W.-Nr. 1.4301 AISI 304</p> <p>Installation: Range of ambient temperature: -30 .. 40 °C Maximum operating pressure: 10 bar Flange standard: DIN Pipe connection: DN 40 Pump inlet: DN 40 Pump outlet: DN 40 Pressure rating: PN 6/10 Port-to-port length: 250 mm Flange size for motor: FT100</p> <p>Electrical data: Motor type: 80A IE Efficiency class: NA Rated power - P2: 0.55 kW Power (P2) required by pump: 0.55 kW Mains frequency: 50 Hz</p>

Position	Qty.	Description
		<p>Rated voltage: 1 x 220-230/240 V</p> <p>Rated current: 4,00/3,65 A</p> <p>Starting current: 280 %</p> <p>Cos phi - power factor: 0,99</p> <p>Rated speed: 2750 rpm</p> <p>Motor efficiency at full load: 66-64 %</p> <p>Number of poles: 2</p> <p>Enclosure class (IEC 34-5): 55 Dust/Jetting</p> <p>Insulation class (IEC 85): F</p> <p>Others:</p> <p>Minimum efficiency index, MEI : 0.70</p> <p>ErP status: EuP Standalone/Prod.</p> <p>Net weight: 27 kg</p> <p>Gross weight: 30.5 kg</p> <p>Shipping volume: 0.12 m³</p>

98957965 TP 40-180/2 50 Hz

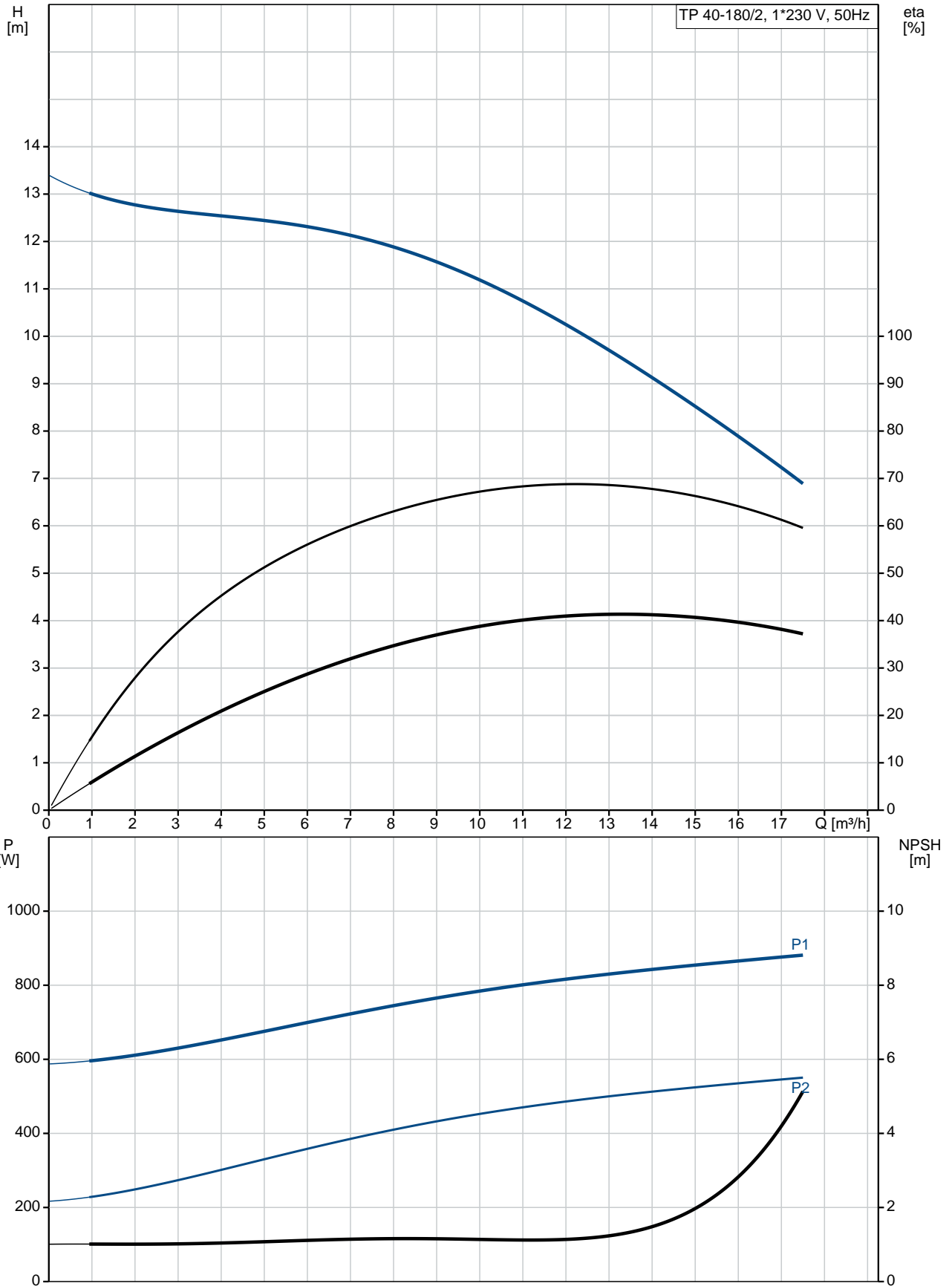

Description	Value
General information:	
Product name:	TP 40-180/2 A-F-A-BQQE
Product No:	98957965
EAN number:	5712604244326
Technical:	
Speed for pump data:	2860 rpm
Rated flow:	12.5 m ³ /h
Rated head:	10 m
Head max:	180 dm
Actual impeller diameter:	98 mm
Primary shaft seal:	BQQE
Curve tolerance:	ISO9906:2012 3B
Pump version:	A
Model:	A
Materials:	
Pump housing:	Cast iron EN-JL1040 ASTM A48-40 B
Impeller:	Stainless steel DIN W.-Nr. 1.4301 AISI 304
Material code:	A
Installation:	
Range of ambient temperature:	-30 .. 40 °C
Maximum operating pressure:	10 bar
Flange standard:	DIN
Connect code:	F
Pipe connection:	DN 40
Pump inlet:	DN 40
Pump outlet:	DN 40
Pressure rating:	PN 6/10
Port-to-port length:	250 mm
Flange size for motor:	FT100
Liquid:	
Pumped liquid:	Water
Liquid temperature range:	-25 .. 120 °C
Liquid temperature during operation:	20 °C
Density:	998.2 kg/m ³
Electrical data:	
Motor type:	80A
IE Efficiency class:	NA
Rated power - P2:	0.55 kW
Power (P2) required by pump:	0.55 kW
Mains frequency:	50 Hz
Rated voltage:	1 x 220-230/240 V
Rated current:	4,00/3,65 A
Starting current:	280 %
Cos phi - power factor:	0,99
Rated speed:	2750 rpm
Motor efficiency at full load:	66-64 %
Number of poles:	2
Enclosure class (IEC 34-5):	55 Dust/Jetting
Insulation class (IEC 85):	F
Motor protec:	PTO

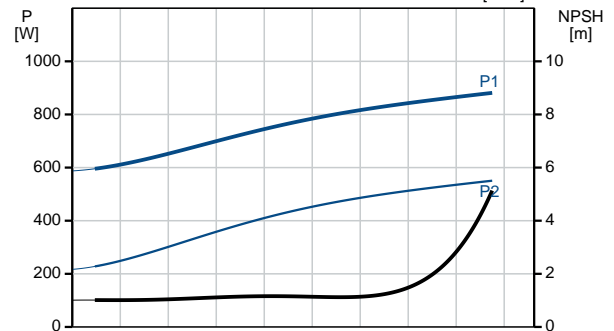
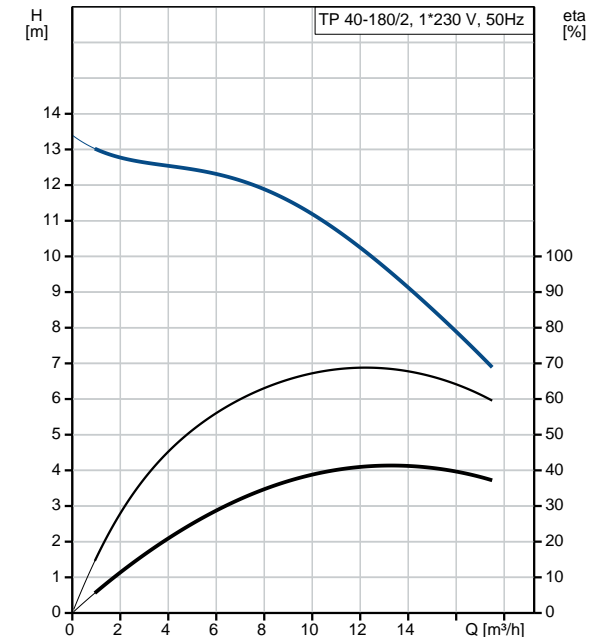



Company name:

Created by:

Phone:

Date:

19/12/2017

Description	Value
Motor No:	85215103
Others:	
Minimum efficiency index, MEI :	0.70
ErP status:	EuP Standalone/Prod.
Net weight:	27 kg
Gross weight:	30.5 kg
Shipping volume:	0.12 m ³

98957965 TP 40-180/2 50 Hz

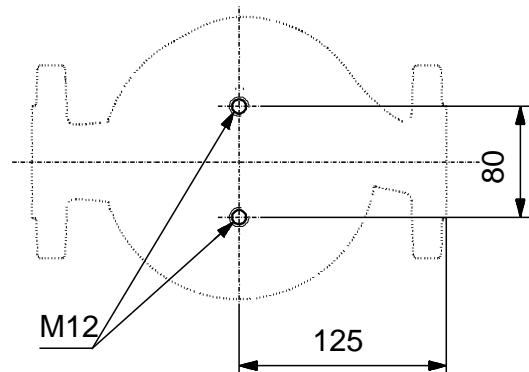
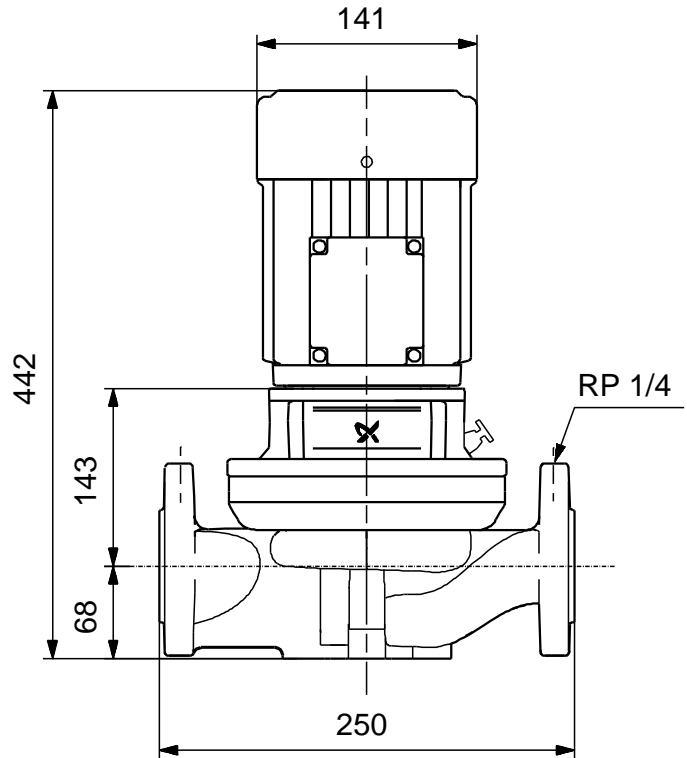
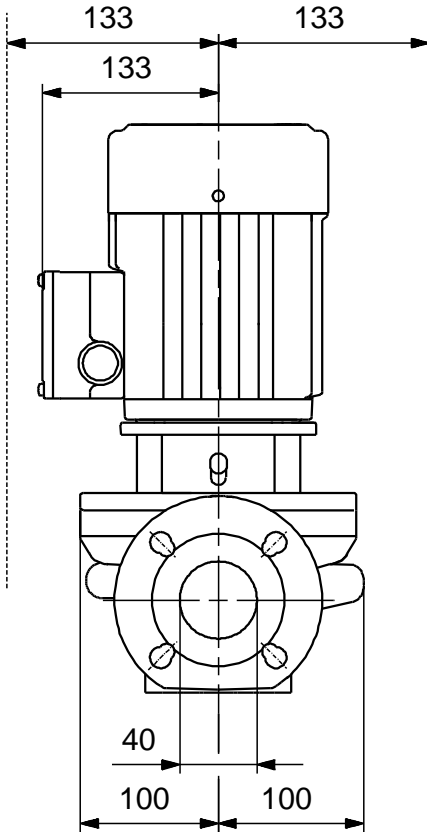

Note! All units are in [mm] unless others are stated.
Disclaimer: This simplified dimensional drawing does not show all details.

98957965 TP 40-180/2 50 Hz

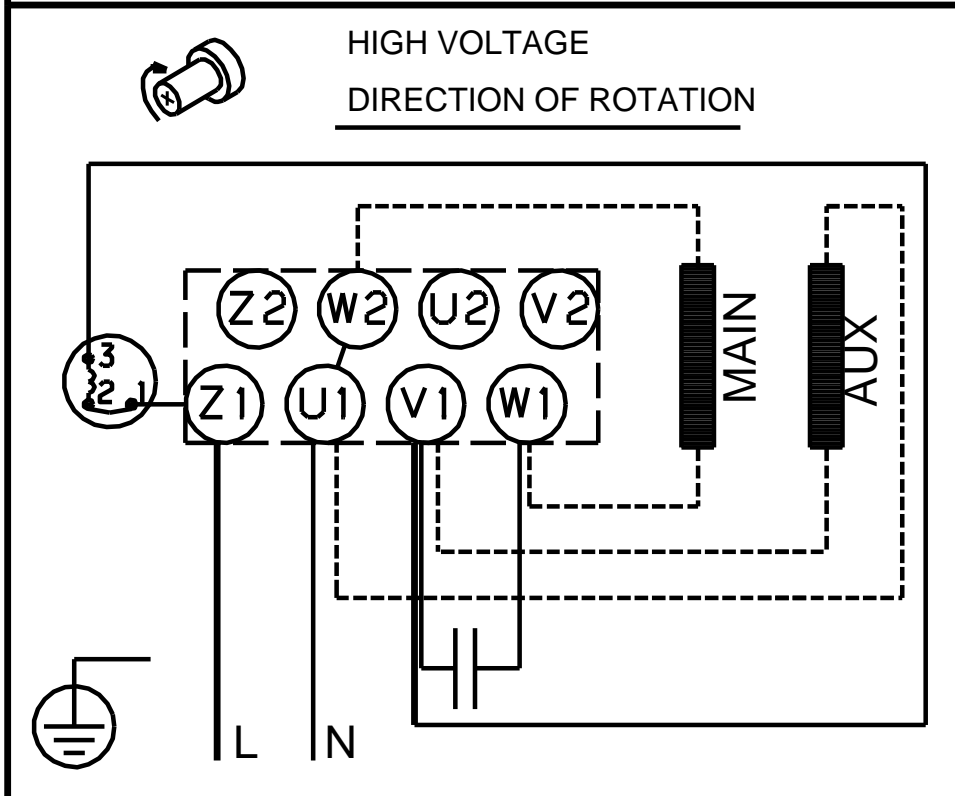
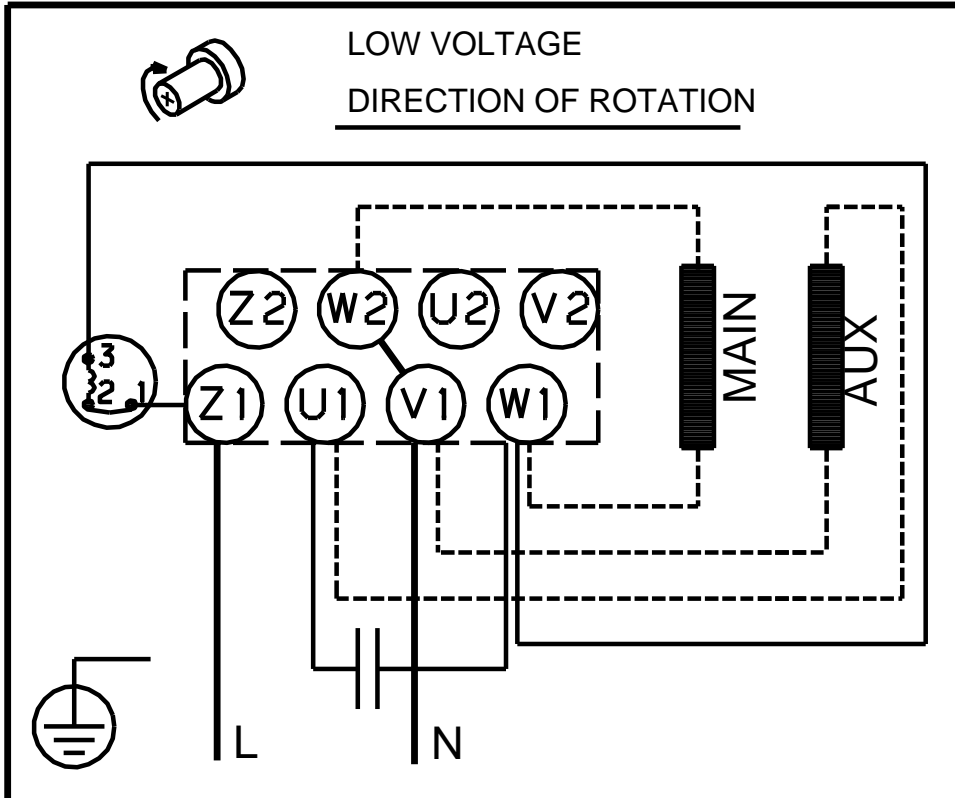

Note! All units are in [mm] unless others are stated.