

Position	Qty.	Description
	1	<p><b>TPD 40-140/4 A-F-A-BQQE</b></p>  <p>Product No.: On request</p> <p>Single-stage, close-coupled, volute twin-head pump with in-line suction and discharge ports of identical diameter. The twin-head pump is designed with two parallel power-heads. The pump is of the top-pull-out design, i.e. the power head (motor, pump head and impeller) can be removed for maintenance or service while the pump housing remains in the pipework.</p> <p>Each power head is fitted with an unbalanced rubber bellows seal. The shaft seal is according to EN 12756. Pipework connection is via PN 16 DIN flanges (EN 1092-2 and ISO 7005-2).</p> <p>Each power head is fitted with a fan-cooled asynchronous motor of identical size.</p> <p><b>Liquid:</b></p> <p>Pumped liquid: Water            Liquid temperature range: -25 .. 120 °C            Liquid temperature during operation: 20 °C            Density: 998.2 kg/m<sup>3</sup></p> <p><b>Technical:</b></p> <p>Rated flow: 15.7 m<sup>3</sup>/h            Rated head: 11.4 m            Actual impeller diameter: 212 mm            Primary shaft seal: BQQE            Curve tolerance: ISO9906:2012 3B</p> <p><b>Materials:</b></p> <p>Pump housing: Cast iron            EN-JL1040            ASTM A48-40 B</p> <p>Impeller: Cast iron            EN-JL1030            ASTM A48-30 B</p> <p><b>Installation:</b></p> <p>Range of ambient temperature: -30 .. 40 °C            Maximum operating pressure: 16 bar            Flange standard: DIN            Pipe connection: DN 40            Pump inlet: DN 40            Pump outlet: DN 40            Pressure rating: PN 16            Port-to-port length: 440 mm            Flange size for motor: FF165</p> <p><b>Electrical data:</b></p> <p>Motor type: 90LB            Rated power - P2: 2 x 1.1 kW            Mains frequency: 50 Hz            Rated voltage: 1 x 220-230 V            Rated current: 7 A</p>



Company name:

Created by:

Phone:

Date:

03/10/2018

Position	Qty.	Description
		Starting current: 390 % Cos phi - power factor: 0.96 Rated speed: 1420-1430 rpm Motor efficiency at full load: 75-76 % Number of poles: 4 Enclosure class (IEC 34-5): 55 Dust/Jetting Insulation class (IEC 85): F  <b>Others:</b> Minimum efficiency index, MEI : 0.7 ErP status: EuP Standalone/Prod. Net weight: 120 kg Gross weight: 134 kg Shipping volume: 0.39 m <sup>3</sup>

## On request TPD 40-140/4 A-F-A-BQQE 50 Hz

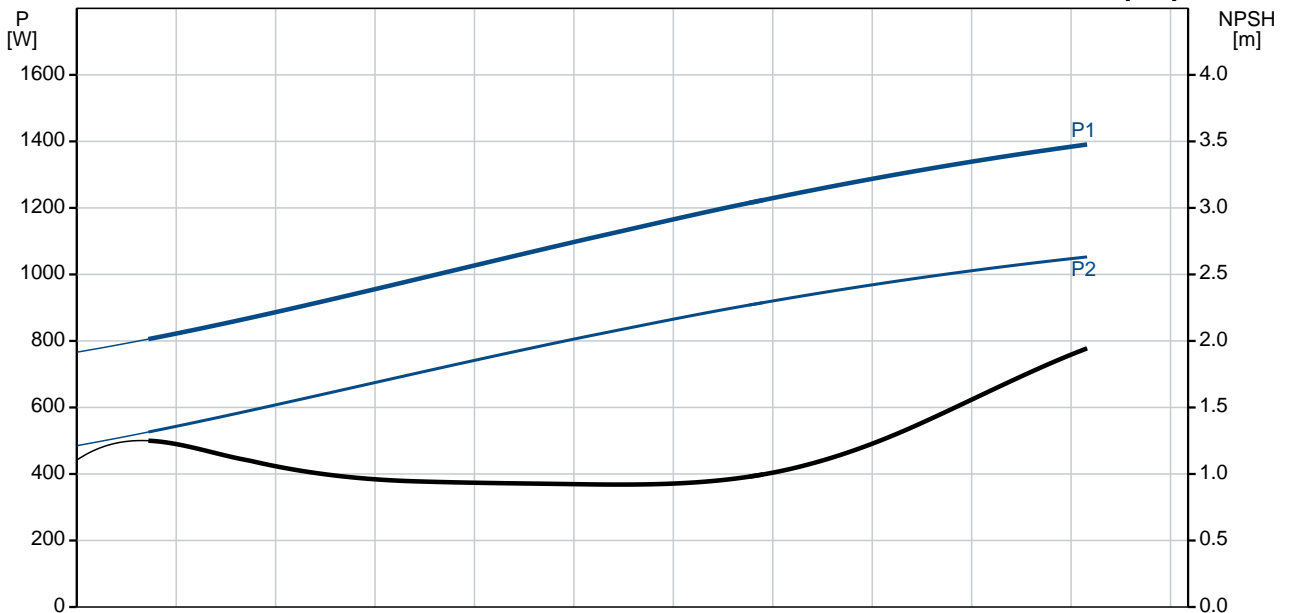
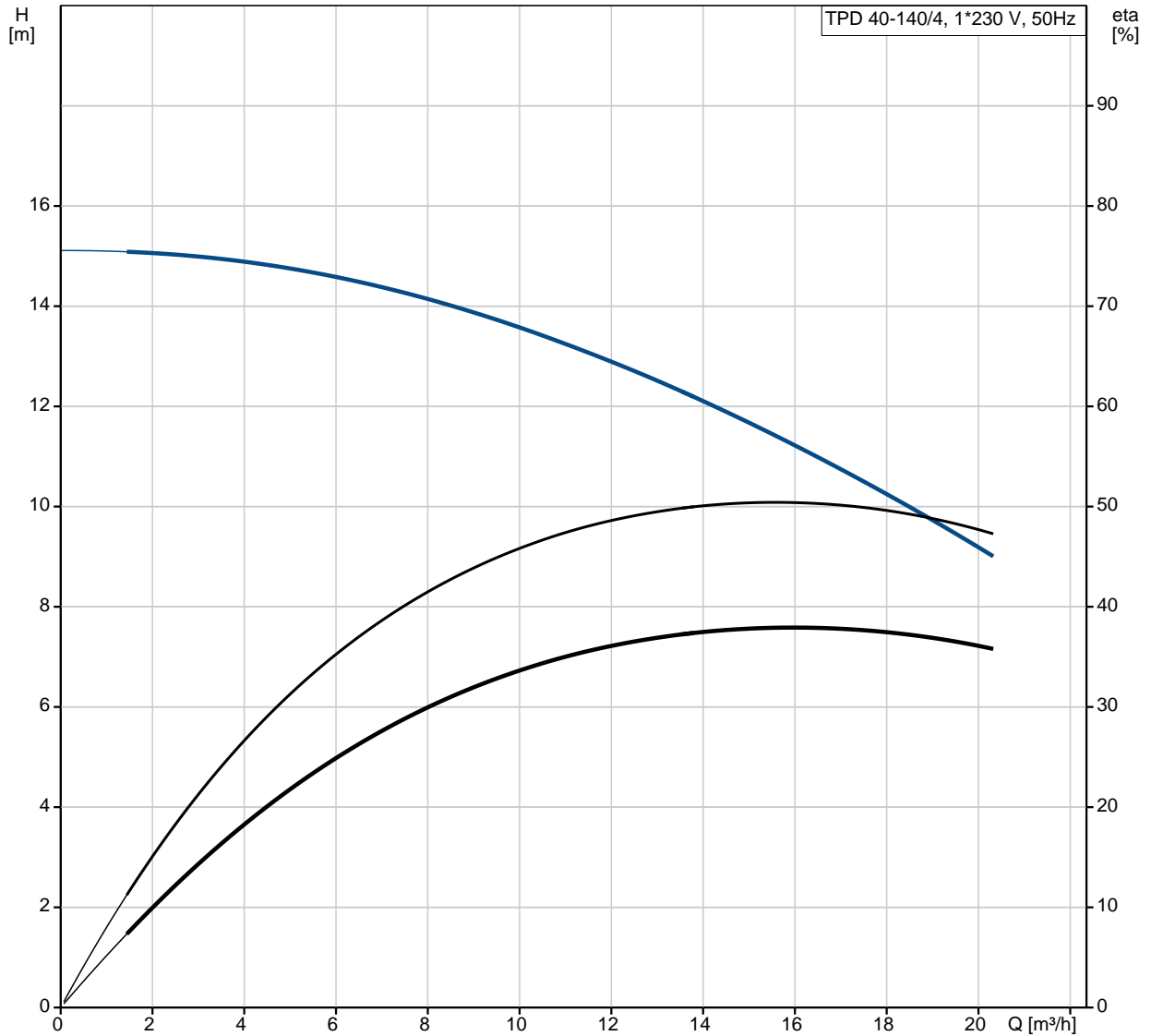

Description	Value
<b>General information:</b>	
Product name:	TPD 40-140/4 A-F-A-BQQE
Product No:	On request
EAN number:	On request
<b>Technical:</b>	
Rated flow:	15.7 m <sup>3</sup> /h
Rated head:	11.4 m
Head max:	140 dm
Actual impeller diameter:	212 mm
Primary shaft seal:	BQQE
Curve tolerance:	ISO9906:2012 3B
Pump version:	A
Model:	A
<b>Materials:</b>	
Pump housing:	Cast iron EN-JL1040 ASTM A48-40 B
Impeller:	Cast iron EN-JL1030 ASTM A48-30 B
Material code:	A
<b>Installation:</b>	
Range of ambient temperature:	-30 .. 40 °C
Maximum operating pressure:	16 bar
Flange standard:	DIN
Pipe connection:	DN 40
Pump inlet:	DN 40
Pump outlet:	DN 40
Pressure rating:	PN 16
Port-to-port length:	440 mm
Flange size for motor:	FF165
Connect code:	F
<b>Liquid:</b>	
Pumped liquid:	Water
Liquid temperature range:	-25 .. 120 °C
Liquid temperature during operation:	20 °C
Density:	998.2 kg/m <sup>3</sup>
<b>Electrical data:</b>	
Motor type:	90LB
Rated power - P2:	2 x 1.1 kW
Mains frequency:	50 Hz
Rated voltage:	1 x 220-230 V
Rated current:	7 A
Starting current:	390 %
Cos phi - power factor:	0.96
Rated speed:	1420-1430 rpm
Motor efficiency at full load:	75-76 %
Number of poles:	4
Enclosure class (IEC 34-5):	55 Dust/Jetting
Insulation class (IEC 85):	F
Motor protec:	PTO
Motor No:	87200343
<b>Others:</b>	
Minimum efficiency index, MEI :	0.7
ErP status:	EuP Standalone/Prod.
Net weight:	120 kg
Gross weight:	134 kg
Shipping volume:	0.39 m <sup>3</sup>

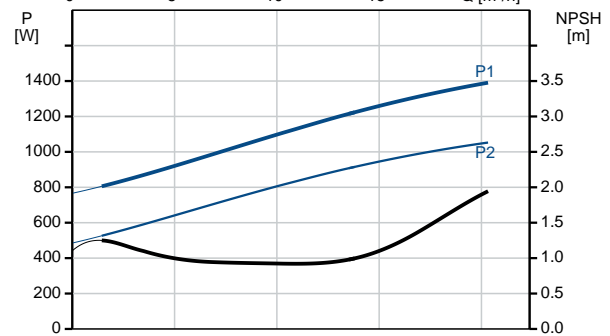
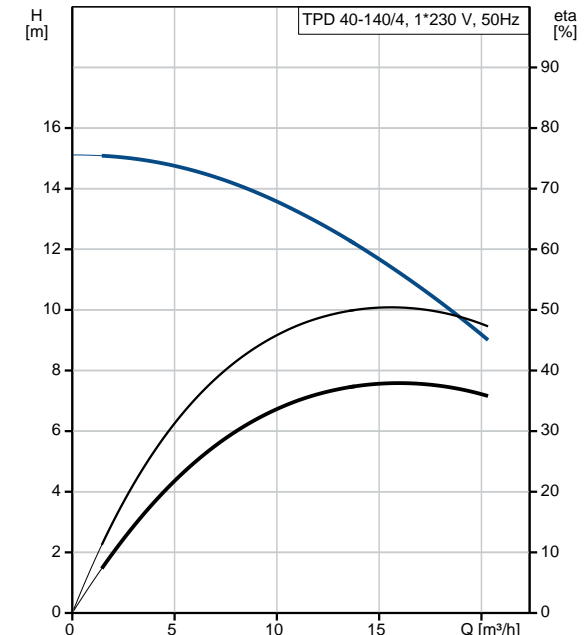

## On request TPD 40-140/4 A-F-A-BQQE 50 Hz

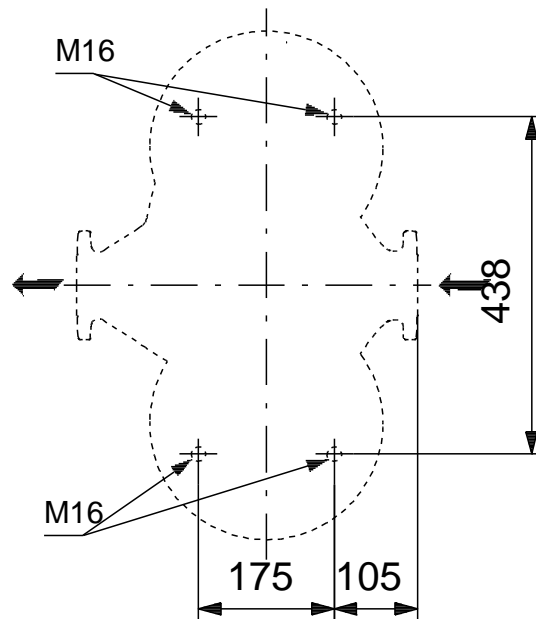
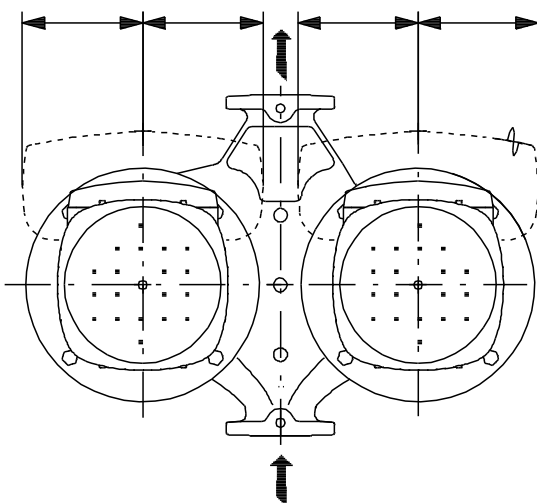
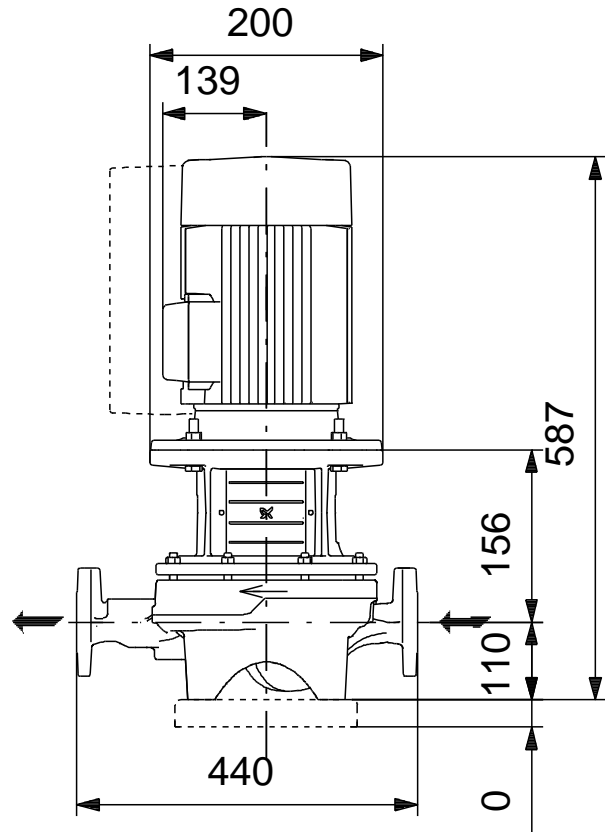
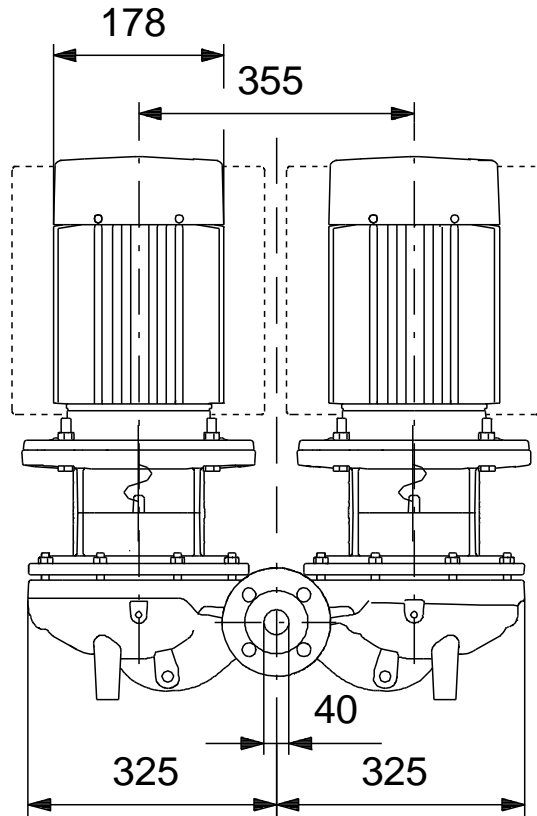

Note! All units are in [mm] unless others are stated.  
Disclaimer: This simplified dimensional drawing does not show all details.

## On request TPD 40-140/4 A-F-A-BQQE 50 Hz

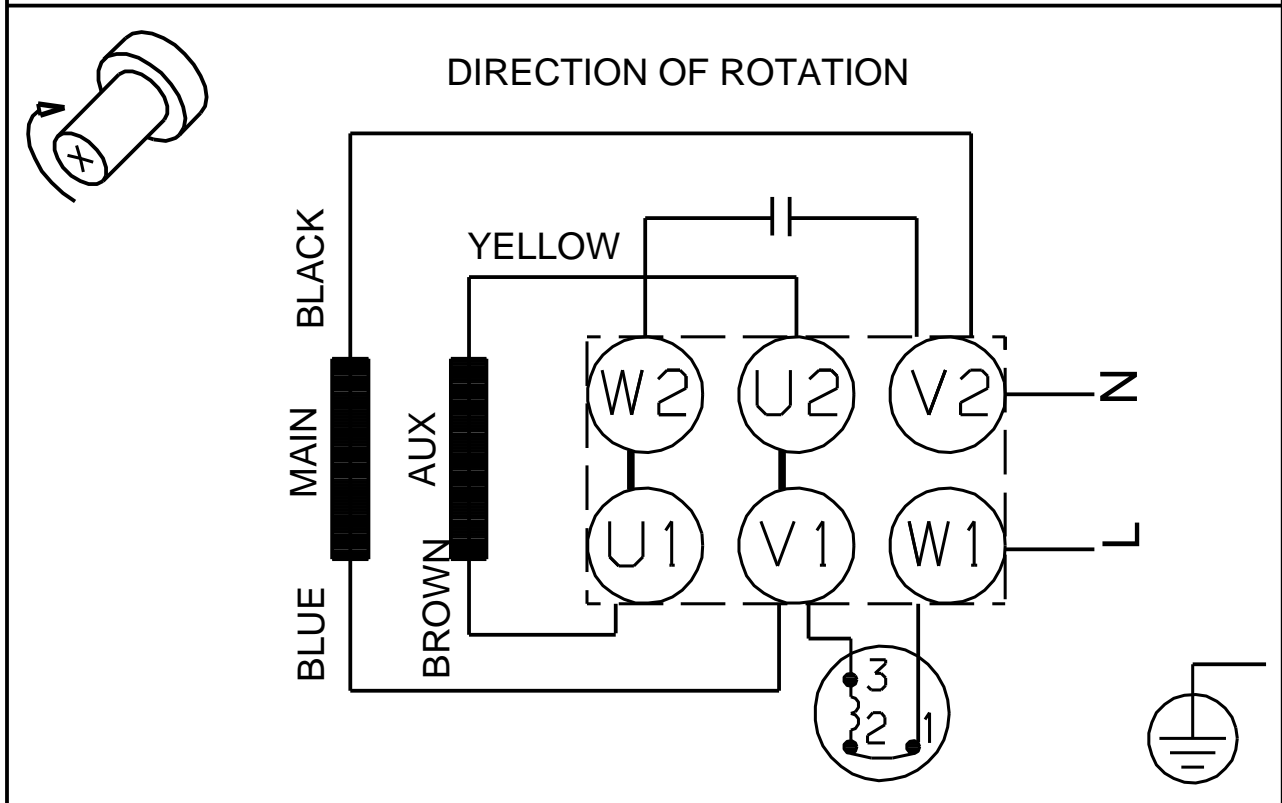
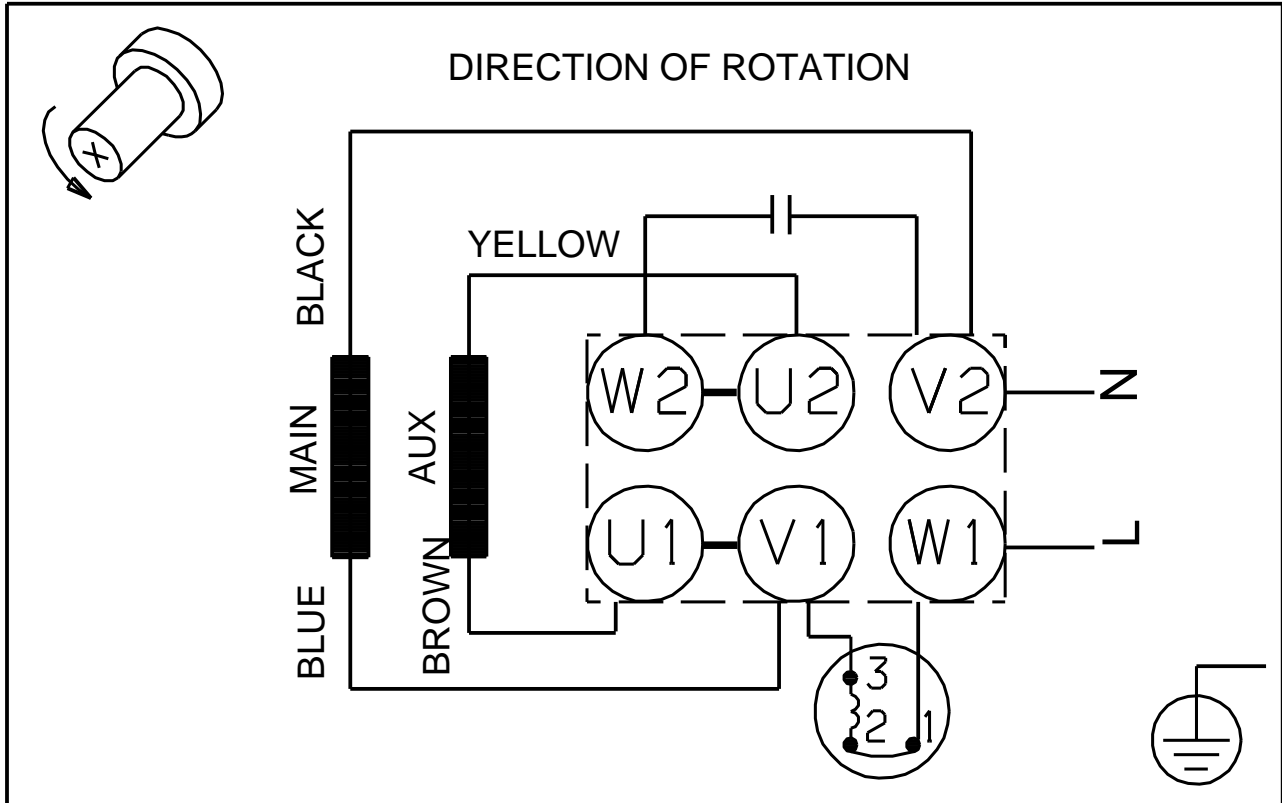

Note! All units are in [mm] unless others are stated.