

Qty. Description

1 TP 125-100/6 A-F-A-BQQE-KX5



Product No.: [98743769](#)

Single-stage, close-coupled, volute pump with in-line suction and discharge ports of identical diameter. The pump is of the top-pull-out design, i.e. the power head (motor, pump head and impeller) can be removed for maintenance or service while the pump housing remains in the pipework.

The pump is fitted with an unbalanced rubber bellows seal. The shaft seal is according to EN 12756. Pipework connection is via PN 16 DIN flanges (EN 1092-2 and ISO 7005-2).

Pipework connection is via PN 16 DIN flanges (EN 1092-2 and ISO 7005-2).

The pump is fitted with a fan-cooled asynchronous motor.

Liquid:

Pumped liquid: Water
 Liquid temperature range: -25 .. 120 °C
 Selected liquid temperature: 20 °C
 Density: 998.2 kg/m³

Technical:

Pump speed on which pump data are based: 970 rpm
 Rated flow: 123 m³/h
 Rated head: 9.22 m
 Actual impeller diameter: 267 mm
 Primary shaft seal: BQQE
 Curve tolerance: ISO9906:2012 3B2

Materials:

Pump housing: Cast iron
 EN-JL1040
 ASTM A48-40 B
 Impeller: Cast iron
 EN-JL1030
 ASTM A48-30 B

Installation:

Range of ambient temperature: -20 .. 55 °C
 Maximum operating pressure: 16 bar
 Flange standard: DIN
 Pipe connection: DN 125
 Pump inlet: DN 125
 Pump outlet: DN 125
 Pressure rating: PN 16
 Port-to-port length: 800 mm
 Flange size for motor: FF265

Electrical data:

Motor type: SIEMENS
 IE Efficiency class: IE3
 Rated power - P2: 4 kW
 Power (P2) required by pump: 4 kW

Qty. Description

Mains frequency: 50 Hz
Rated voltage: 3 x 380-420D/660-725Y V
Rated current: 9,10-8,20/5,20-4,80 A
Starting current: 650-650 %
Cos phi - power factor: 0.8
Rated speed: 970 rpm
Efficiency: IE3 86,8%
Motor efficiency at full load: 86.8-86.8 %
Motor efficiency at 3/4 load: 87.7-87.7 %
Motor efficiency at 1/2 load: 87.4-87.4 %
Number of poles: 6
Enclosure class (IEC 34-5): 55 Dust/Jetting
Insulation class (IEC 85): F
Motor No: 83W15213

Others:

Minimum efficiency index, MEI η_{min} : 0.7
ErP status: EuP Standalone/Prod.
Net weight: 236 kg
Gross weight: 269 kg
Shipping volume: 0.75 m³
Danish VVS No.: 381727100
Finnish LVI No.: 4616137
Country of origin: HU
Custom tariff no.: 84137051

98743769 TP 125-100/6 A-F-A-BQQE-KX5 50 Hz

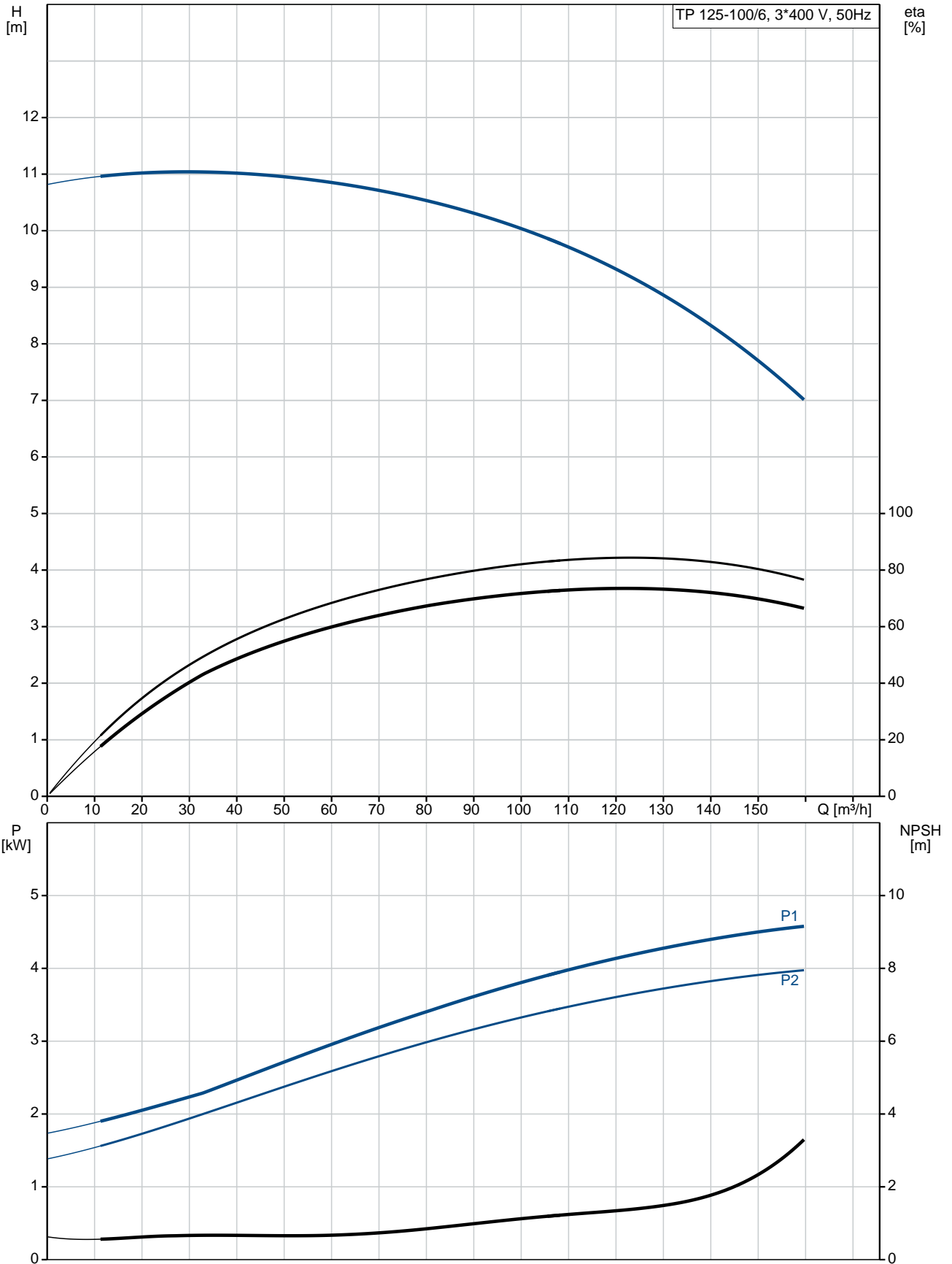

Description	Value
General information:	
Product name:	TP 125-100/6 A-F-A-BQQE-KX5
Product No:	98743769
EAN number:	5712600824904 5712600824904
Price:	4.379,00 GBP
Technical:	
Pump speed on which pump data are based:	970 rpm
Rated flow:	123 m ³ /h
Rated head:	9.22 m
Head max:	100 dm
Actual impeller diameter:	267 mm
Primary shaft seal:	BQQE
Curve tolerance:	ISO9906:2012 3B2
Pump version:	A
Model:	A
Materials:	
Pump housing:	Cast iron EN-JL1040 ASTM A48-40 B
Impeller:	Cast iron EN-JL1030 ASTM A48-30 B
Material code:	A
Installation:	
Range of ambient temperature:	-20 .. 55 °C
Maximum operating pressure:	16 bar
Flange standard:	DIN
Pipe connection:	DN 125
Pump inlet:	DN 125
Pump outlet:	DN 125
Pressure rating:	PN 16
Port-to-port length:	800 mm
Flange size for motor:	FF265
Connect code:	F
Liquid:	
Pumped liquid:	Water
Liquid temperature range:	-25 .. 120 °C
Selected liquid temperature:	20 °C
Density:	998.2 kg/m ³
Electrical data:	
Motor type:	SIEMENS
IE Efficiency class:	IE3
Rated power - P2:	4 kW
Power (P2) required by pump:	4 kW
Mains frequency:	50 Hz
Rated voltage:	3 x 380-420D/660-725Y V
Rated current:	9,10-8,20/5,20-4,80 A
Starting current:	650-650 %
Cos phi - power factor:	0.8
Rated speed:	970 rpm
Efficiency:	IE3 86,8%
Motor efficiency at full load:	86.8-86.8 %
Motor efficiency at 3/4 load:	87.7-87.7 %
Motor efficiency at 1/2 load:	87.4-87.4 %
Number of poles:	6
Enclosure class (IEC 34-5):	55 Dust/Jetting

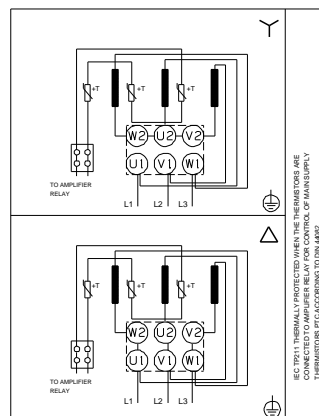
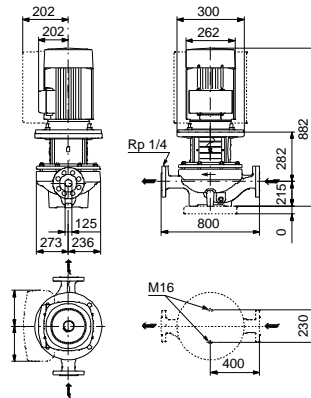
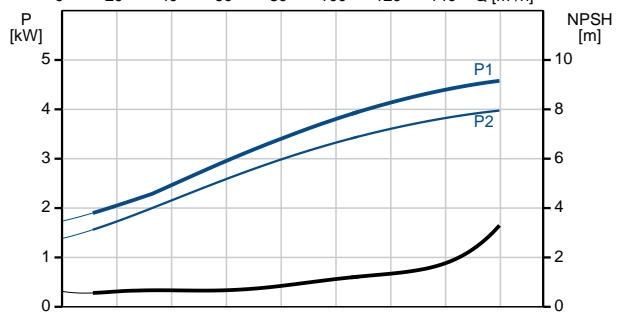
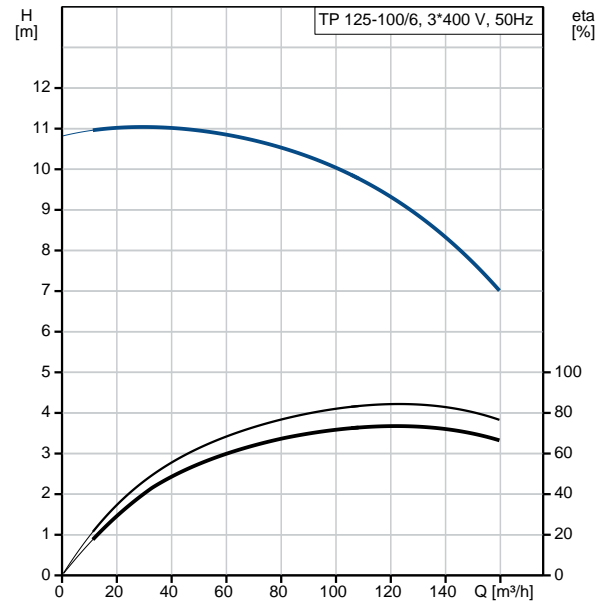



Company name:

Created by:

Phone:

Date:

10/03/2020

Description	Value
Insulation class (IEC 85):	F
Motor protec:	PTC
Motor No:	83W15213
Others:	
Minimum efficiency index, MEI %:	0.7
ErP status:	EuP Standalone/Prod.
Net weight:	236 kg
Gross weight:	269 kg
Shipping volume:	0.75 m ³
Danish VVS No.:	381727100
Finnish LVI No.:	4616137
Country of origin:	HU
Custom tariff no.:	84137051

98743769 TP 125-100/6 A-F-A-BQQE-KX5 50 Hz

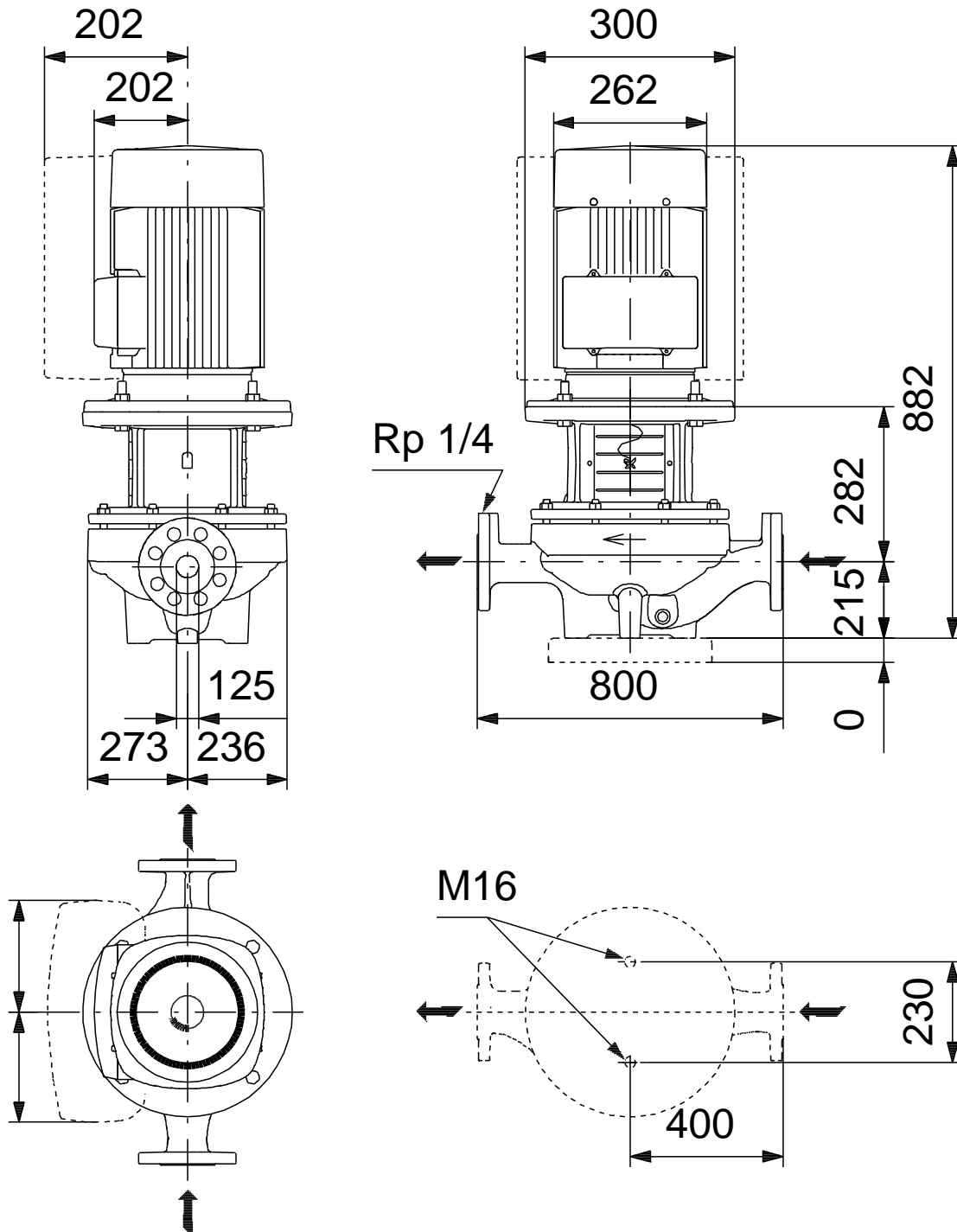

Note! All units are in [mm] unless others are stated.
Disclaimer: This simplified dimensional drawing does not show all details.