

Position	Qty.	Description
	1	<p><b>SP 11-3</b></p>  <p>Product No.: <a href="#">98699297</a></p> <p>Submersible borehole pump, suitable for pumping clean water. Can be installed vertically or horizontally. All steel components are made in stainless steel, EN 1.4301 (AISI 304), that ensures high corrosive resistance. This pump carries drinking water approval.</p> <p>The pump is fitted with a 0.75 kW MS402 motor with sand shield, lip seal, water-lubricated journal bearings and a volume compensating diaphragm. The motor is a canned type submersible motor offering good mechanical stability and high efficiency. Suitable for temperatures up to 40 °C.</p> <p>The motor is not fitted with a temperature sensor. If temperature monitoring is desired, a Pt1000 sensor can be fitted.</p> <p>The motor is for direct-on-line starting (DOL).</p> <p><b>Liquid:</b></p> <p>Pumped liquid: Water            Maximum liquid temperature: 40 °C            Max liquid t at 0.15 m/sec: 40 °C            Liquid temperature during operation: 20 °C            Density: 998.2 kg/m<sup>3</sup></p> <p><b>Technical:</b></p> <p>Pump speed on which pump data are based: 2900 rpm            Rated flow: 11 m<sup>3</sup>/h            Rated head: 13.3 m            Shaft seal for motor: LIPSEAL            Approvals on nameplate: CE,EAC            Curve tolerance: ISO9906:2012 3B            Motor version: T40</p> <p><b>Materials:</b></p> <p>Pump: Stainless steel            EN 1.4301            AISI 304            Impeller: Stainless steel            EN 1.4301            AISI 304            Motor: Stainless steel            DIN W.-Nr. 1.4301            AISI 304</p> <p><b>Installation:</b></p> <p>Pump outlet: RP2            Motor diameter: 4 inch</p> <p><b>Electrical data:</b></p> <p>Motor type: MS402            Type of motor: CSIR            Rated power - P2: 0.75 kW            Power (P2) required by pump: 0.75 kW</p>



Company name:

Created by:

Phone:

Date:

14/11/2018

Position	Qty.	Description
		Mains frequency: 50 Hz Rated voltage: 1 x 240 V Rated current: 7 A Starting current: 390 % Cos phi - power factor: 0.79 Rated speed: 2860 rpm Start. method: direct-on-line Enclosure class (IEC 34-5): IP68 Insulation class (IEC 85): B Built-in temp. transmitter: no  <b>Others:</b> Minimum efficiency index, MEI =: 0.60 ErP status: EuP Standalone/Prod. Net weight: 15.7 kg Gross weight: 17.7 kg Shipping volume: 0.016 m <sup>3</sup>

## 98699297 SP 11-3 50 Hz

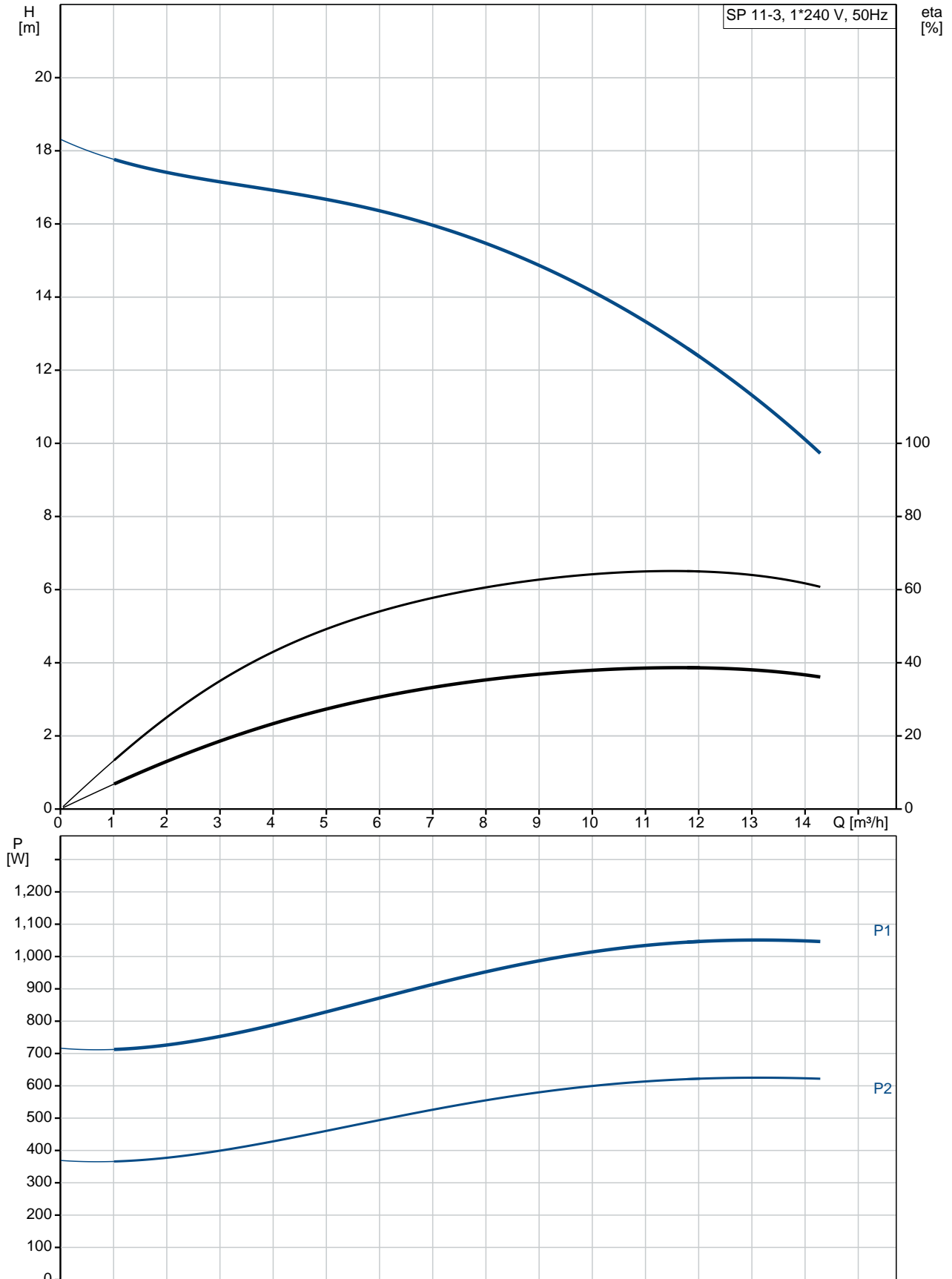

Description	Value
<b>General information:</b>	
Product name:	SP 11-3
Product No:	98699297
EAN number:	5712600110779
<b>Technical:</b>	
Pump speed on which pump data are based:	2900 rpm
Rated flow:	11 m <sup>3</sup> /h
Rated head:	13.3 m
Stages:	3
Impeller reduc.:	NONE
Shaft seal for motor:	LIPSEAL
Approvals on nameplate:	CE,EAC
Curve tolerance:	ISO9906:2012 3B
Model:	A
Valve:	YES
Motor version:	T40
<b>Materials:</b>	
Pump:	Stainless steel EN 1.4301
	AISI 304
Impeller:	Stainless steel EN 1.4301
	AISI 304
Motor:	Stainless steel DIN W.-Nr. 1.4301
	AISI 304
<b>Installation:</b>	
Pump outlet:	RP2
Motor diameter:	4 inch
<b>Liquid:</b>	
Pumped liquid:	Water
Maximum liquid temperature:	40 °C
Max liquid t at 0.15 m/sec:	40 °C
Liquid temperature during operation:	20 °C
Density:	998.2 kg/m <sup>3</sup>
<b>Electrical data:</b>	
Motor type:	MS402
Type of motor:	CSIR
Applic. motor:	NEMA
Rated power - P2:	0.75 kW
Power (P2) required by pump:	0.75 kW
Mains frequency:	50 Hz
Rated voltage:	1 x 240 V
Rated current:	7 A
Starting current:	390 %
Cos phi - power factor:	0.79
Rated speed:	2860 rpm
Start. method:	direct-on-line
Enclosure class (IEC 34-5):	IP68
Insulation class (IEC 85):	B
Motor protec:	CONTACT
Thermal protec:	internal
Built-in temp. transmitter:	no
Motor No:	79243104
<b>Others:</b>	
Minimum efficiency index, MEI =:	0.60
ErP status:	EuP Standalone/Prod.

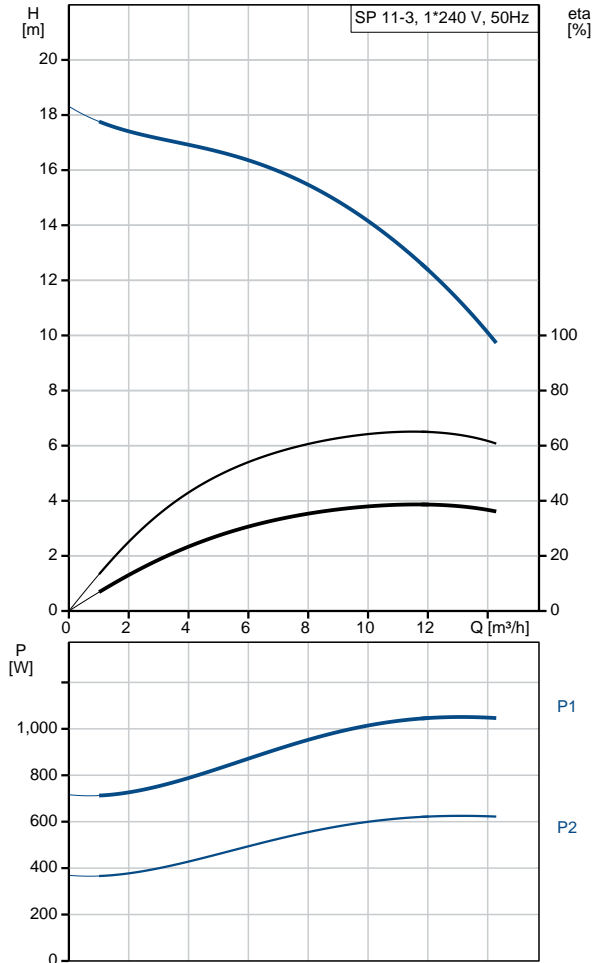



Company name:

Created by:

Phone:

Date:

14/11/2018

Description	Value
Net weight:	15.7 kg
Gross weight:	17.7 kg
Shipping volume:	0.016 m <sup>3</sup>

## 98699297 SP 11-3 50 Hz

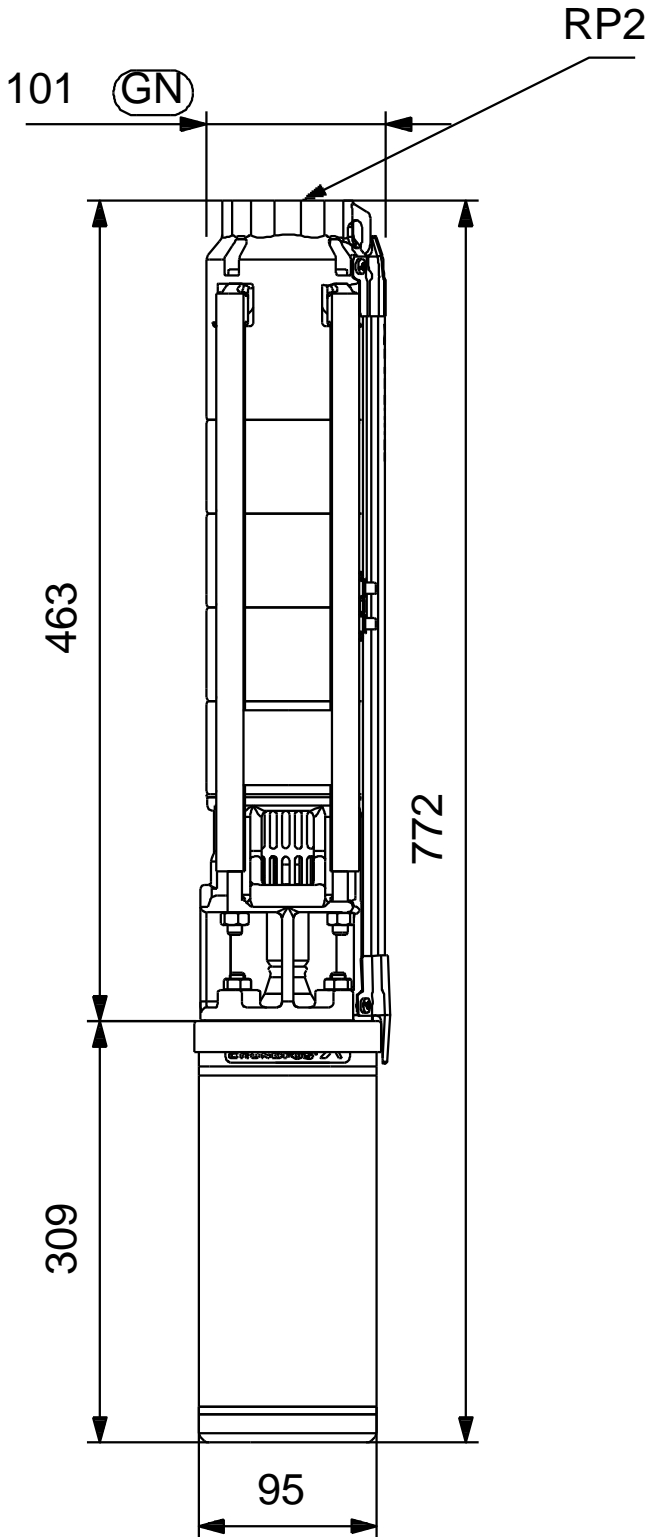

Note! All units are in [mm] unless others are stated.  
Disclaimer: This simplified dimensional drawing does not show all details.

## 98699297 SP 11-3 50 Hz

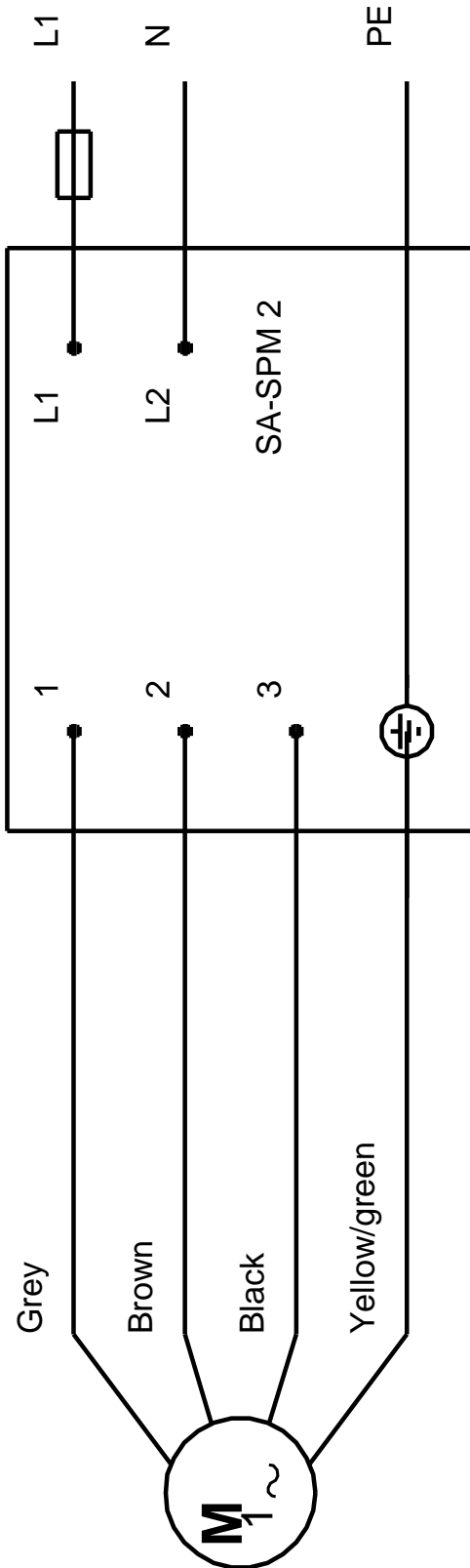

Note! All units are in [mm] unless others are stated.