

| Position | Qty. | Description |
|----------|------|---|
| | 1 | <p>SP 9-5</p>  <p>Product No.: 98699025</p> <p>Submersible borehole pump, suitable for pumping clean water. Can be installed vertically or horizontally. All steel components are made in stainless steel, EN 1.4301 (AISI 304), that ensures high corrosive resistance. This pump carries drinking water approval.</p> <p>The pump is fitted with a 1.1 kW MS402 motor with sand shield, lip seal, water-lubricated journal bearings and a volume compensating diaphragm. The motor is a canned type submersible motor offering good mechanical stability and high efficiency. Suitable for temperatures up to 40 °C.</p> <p>The motor is not fitted with a temperature sensor. If temperature monitoring is desired, a Pt1000 sensor can be fitted.</p> <p>The motor is for direct-on-line starting (DOL).</p> <p>Liquid:</p> <p>Pumped liquid: Water Maximum liquid temperature: 40 °C Max liquid t at 0.15 m/sec: 40 °C Liquid temperature during operation: 20 °C Density: 998.2 kg/m³</p> <p>Technical:</p> <p>Pump speed on which pump data are based: 2900 rpm Rated flow: 9 m³/h Rated head: 25.5 m Shaft seal for motor: LIPSEAL Approvals on nameplate: CE,EAC Curve tolerance: ISO9906:2012 3B Motor version: T40</p> <p>Materials:</p> <p>Pump: Stainless steel EN 1.4301 AISI 304 Impeller: Stainless steel EN 1.4301 AISI 304 Motor: Stainless steel DIN W.-Nr. 1.4301 AISI 304</p> <p>Installation:</p> <p>Pump outlet: RP2 Motor diameter: 4 inch</p> <p>Electrical data:</p> <p>Motor type: MS402 Type of motor: CSCR Rated power - P2: 1.1 kW Power (P2) required by pump: 1.1 kW</p> |



Company name:

Created by:

Phone:

Date:

14/11/2018

| Position | Qty. | Description |
|----------|------|---|
| | | Mains frequency: 50 Hz Rated voltage: 1 x 240 V Rated current: 7.1 A Starting current: 480 % Cos phi - power factor: 0.99 Rated speed: 2860 rpm Start. method: direct-on-line Enclosure class (IEC 34-5): IP68 Insulation class (IEC 85): B Built-in temp. transmitter: no Others: Minimum efficiency index, MEI =: 0.70 ErP status: EuP Standalone/Prod. Net weight: 17.7 kg Gross weight: 19.9 kg Shipping volume: 0.016 m ³ |

98699025 SP 9-5 50 Hz

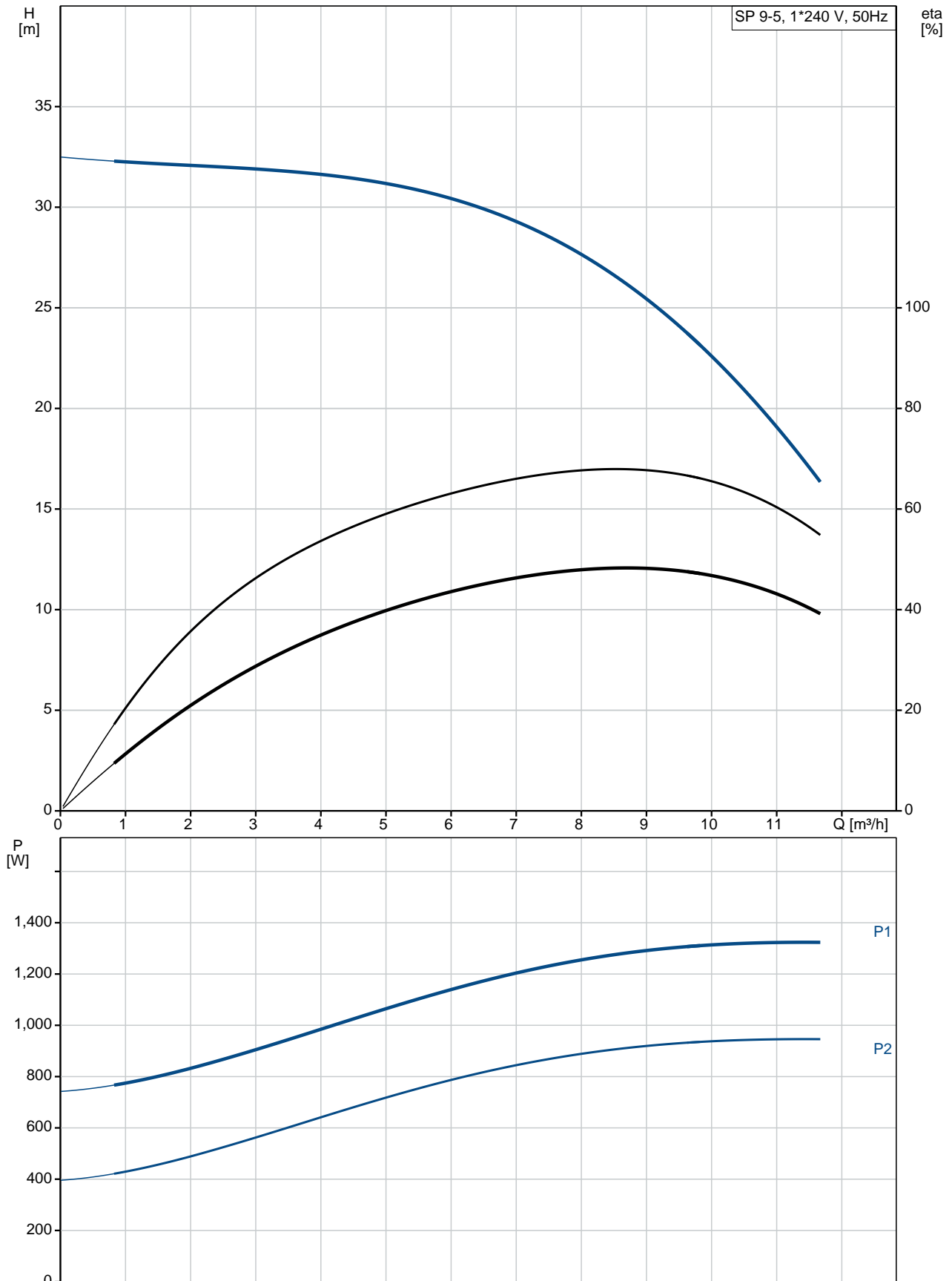

| Description | Value |
|--|--------------------------------------|
| General information: | |
| Product name: | SP 9-5 |
| Product No: | 98699025 |
| EAN number: | 5712600105331 |
| Technical: | |
| Pump speed on which pump data are based: | 2900 rpm |
| Rated flow: | 9 m ³ /h |
| Rated head: | 25.5 m |
| Stages: | 5 |
| Impeller reduc.: | NONE |
| Shaft seal for motor: | LIPSEAL |
| Approvals on nameplate: | CE,EAC |
| Curve tolerance: | ISO9906:2012 3B |
| Model: | A |
| Valve: | YES |
| Motor version: | T40 |
| Materials: | |
| Pump: | Stainless steel EN 1.4301 |
| | AISI 304 |
| Impeller: | Stainless steel EN 1.4301 |
| | AISI 304 |
| Motor: | Stainless steel DIN W.-Nr. 1.4301 |
| | AISI 304 |
| Installation: | |
| Pump outlet: | RP2 |
| Motor diameter: | 4 inch |
| Liquid: | |
| Pumped liquid: | Water |
| Maximum liquid temperature: | 40 °C |
| Max liquid t at 0.15 m/sec: | 40 °C |
| Liquid temperature during operation: | 20 °C |
| Density: | 998.2 kg/m ³ |
| Electrical data: | |
| Motor type: | MS402 |
| Type of motor: | CSCR |
| Applic. motor: | NEMA |
| Rated power - P2: | 1.1 kW |
| Power (P2) required by pump: | 1.1 kW |
| Mains frequency: | 50 Hz |
| Rated voltage: | 1 x 240 V |
| Rated current: | 7.1 A |
| Starting current: | 480 % |
| Cos phi - power factor: | 0.99 |
| Rated speed: | 2860 rpm |
| Start. method: | direct-on-line |
| Enclosure class (IEC 34-5): | IP68 |
| Insulation class (IEC 85): | B |
| Motor protec: | CONTACT |
| Thermal protec: | internal |
| Built-in temp. transmitter: | no |
| Motor No: | 79243105 |
| Others: | |
| Minimum efficiency index, MEI =: | 0.70 |
| ErP status: | EuP Standalone/Prod. |

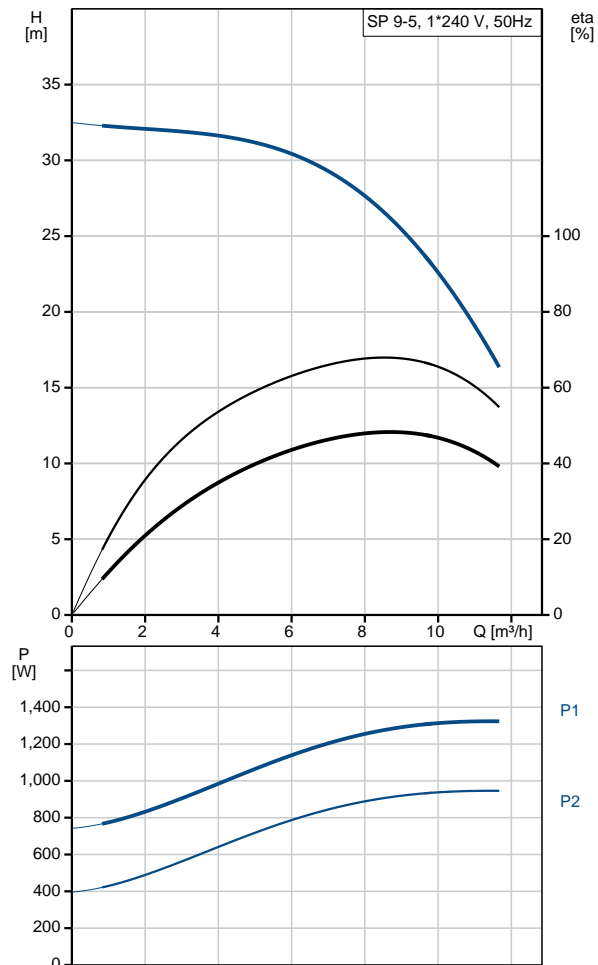



Company name:

Created by:

Phone:

Date:

14/11/2018

| Description | Value |
|------------------|----------------------|
| Net weight: | 17.7 kg |
| Gross weight: | 19.9 kg |
| Shipping volume: | 0.016 m ³ |

98699025 SP 9-5 50 Hz

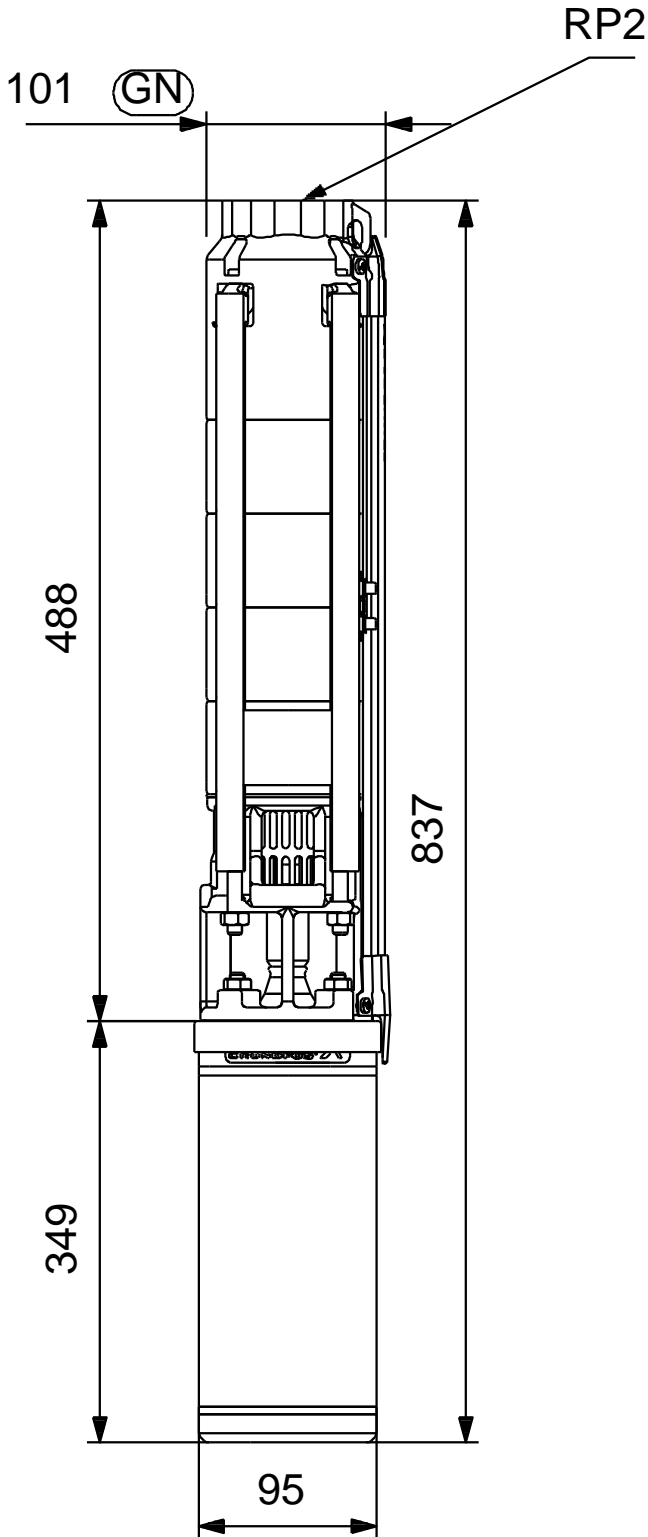

Note! All units are in [mm] unless others are stated.
Disclaimer: This simplified dimensional drawing does not show all details.

98699025 SP 9-5 50 Hz

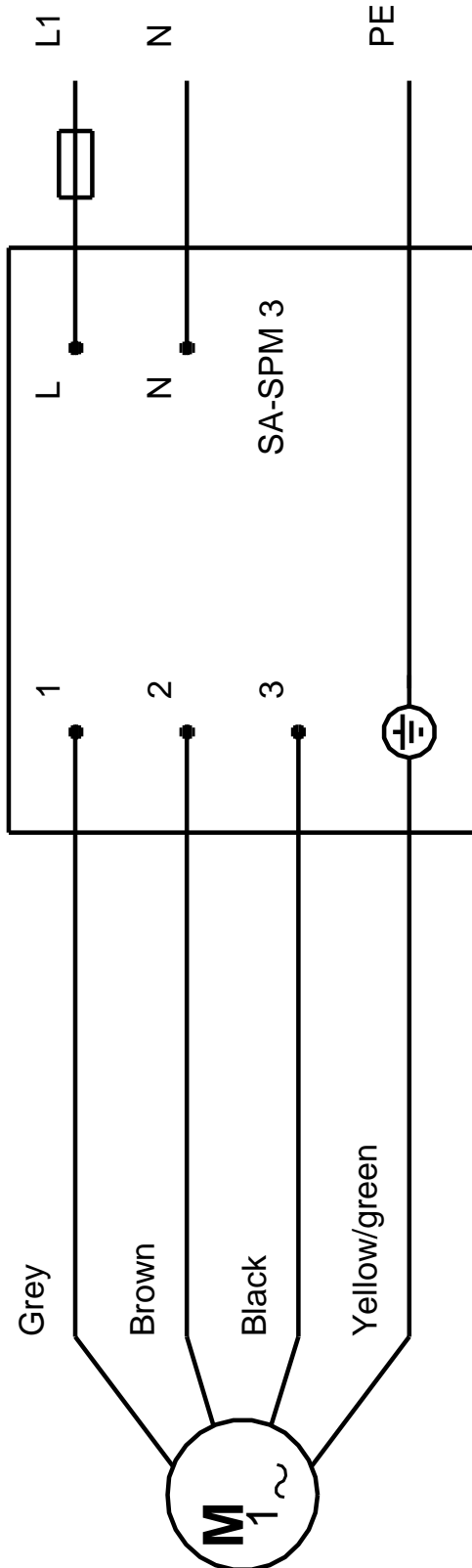

Note! All units are in [mm] unless others are stated.